

Air Force Institute of Technology

AFIT Scholar

Theses and Dissertations

Student Graduate Works

3-2008

Comparative Kinetics and Distribution to Target Tissues of Organophosphates Using Physiologically-Based Pharmacokinetic Modeling

Rick E. Vermillion

Follow this and additional works at: <https://scholar.afit.edu/etd>



Part of the [Environmental Chemistry Commons](#)

Recommended Citation

Vermillion, Rick E., "Comparative Kinetics and Distribution to Target Tissues of Organophosphates Using Physiologically-Based Pharmacokinetic Modeling" (2008). *Theses and Dissertations*. 2841.
<https://scholar.afit.edu/etd/2841>

This Thesis is brought to you for free and open access by the Student Graduate Works at AFIT Scholar. It has been accepted for inclusion in Theses and Dissertations by an authorized administrator of AFIT Scholar. For more information, please contact richard.mansfield@afit.edu.



**COMPARATIVE KINETICS AND DISTRIBUTION TO TARGET TISSUES OF
ORGANOPHOSPHATES USING PHYSIOLOGICALLY – BASED
PHARMACOKINETIC MODELING**

THESIS

Rick E Vermillion, Captain, USAF

AFIT/GEM/ENV/08-M20

**DEPARTMENT OF THE AIR FORCE
AIR UNIVERSITY**

AIR FORCE INSTITUTE OF TECHNOLOGY

Wright-Patterson Air Force Base, Ohio

APPROVED FOR PUBLIC RELEASE; DISTRIBUTION UNLIMITED

The views expressed in this thesis are those of the author and do not reflect the official policy or position of the United States Air Force, Department of Defense, or the U.S. Government.

AFIT/GEM/ENV/08-M20

**COMPARATIVE KINETICS AND DISTRIBUTION TO TARGET TISSUES OF
ORGANOPHOSPHATES USING PHYSIOLOGICALLY – BASED
PHARMACOKINETIC MODELING**

THESIS

Presented to the Faculty

Department of Systems Engineering and Management

Graduate School of Engineering and Management

Air Force Institute of Technology

Air University

Air Education and Training Command

In Partial Fulfillment of the Requirements for the
Degree of Master of Science in Engineering Management

Rick E Vermillion, BS

Captain, USAF

March 2008

APPROVED FOR PUBLIC RELEASE; DISTRIBUTION UNLIMITED

AFIT/GEM/ENV/08-M20

COMPARATIVE KINETICS AND DISTRIBUTION TO TARGET TISSUES OF
ORGANOPHOSPHATES USING PHYSIOLOGICALLY – BASED
PHARMACOKINETIC MODELING

Rick E Vermillion, BS

Captain, USAF

Approved:

//SIGNED//
Dr. Michael L. Shelley (Chairman)

2/25/08
Date

//SIGNED//
David A. Smith, Lt Col, USAF (Member)

2/8/08
Date

//SIGNED//
Dr. Jeffery M. Gearhart (Member)

2/8/08
Date

Abstract

A physiologically – based pharmacokinetic model has been developed to examine the effects of organophosphates on the levels of acetylcholine in different tissues throughout the mammalian body. Many organophosphate-like chemical and kinetic characteristics are tested without reference to a specific chemical. Characteristics include partition coefficients, metabolic constants, the inhibition coefficient which determines the rate free AChE is bound by an organophosphate and becomes inhibited AChE, the aging rate which determines the rate in which the bond between AChE and the organophosphate become permanent, and the regeneration rate which determines the rate where the bound AChE is separated from the organophosphate and becomes free AChE once again. Two separate exposure scenarios are tested and compared against a baseline. The baseline consists of a direct inhalation exposure which allows 100 percent of the organophosphate to enter into the blood stream via blood – gas exchange. The first exposure scenario examines the effects of bronchial scrubbing (via inhalation) of a fraction of the inhaled agent with direct absorption into bronchial tissue under different exposure conditions and compares them with the inhalation exposures. The second scenario is a study of dermal exposures and compares the levels of ACh in the different tissues with those in the inhalation (baseline) tests.

Organophosphates that are absorbed directly into the bronchial tissue exhibit little variation on the levels of ACh buildup in any of the tissue groups tested when compared to the inhalation exposures. No matter what the scrubbing coefficient used, or the

combination of the parameters (partition coefficients, inhibition coefficient, aging rate, and regeneration rate) values, the change in ACh was minimal. This suggests that the scrubbing of the chemical as it passes through the airway does not help the individual being exposed. The changes are so minor that the individual will experience the same symptoms whether bronchial scrubbing takes place or not.

The results showed different behavior between inhalation and dermal exposures. The levels of ACh present in the liver, kidneys, brain, slowly perfused tissue, richly perfused tissue, and diaphragm were lower with the dermal tests. These results suggest that an individual may have additional time to don protective equipment before the levels of ACh are high enough to render the person incapable of doing so.

Acknowledgments

First off, I would like to thank my wife for her continued patience and support throughout my time at AFIT. She was instrumental in helping me to relax and remember the important things in life. I would also like to thank my children for keeping my spirits high and always making me laugh. Next, I would like to express my appreciation to my thesis advisor. His patience and kindness helped me to excel, see things from a different perspective, and learn about the model building process.

I would also like to thank the other members of my committee for their support and insight throughout the entire process. Their experience and knowledge was insurmountable and helped me to advance in my academic journey. Lastly, I would like to thank the faculty, staff, education technicians, and fellow students who unselfishly went out of their way to help me complete this chapter of my life.

Rick E Vermillion

This Note is not to be included with the Acknowledgments – it is for information only: *It is prohibited to include any personal information in the following categories about U.S. citizens, DOD Employees and military personnel: social security account numbers; home addresses; dates of birth; telephone numbers other than duty officers which are appropriately made available to the general public; names, locations and any other identifying information about family members of DOD employees and military personnel.*

Table of Contents

	Page
Abstract.....	iv
Acknowledgments.....	vi
Table of Contents.....	vii
List of Figures.....	x
List of Tables.....	xii
I. Introduction.....	1
Introduction.....	1
Background.....	1
Problem Statement.....	3
Research Question.....	4
Investigative Questions.....	5
II. Literature Review.....	6
What are organophosphates.....	6
Release Mechanisms.....	8
How do organophosphates work.....	9
Symptoms.....	12
Effect of different organophosphates.....	15
Bronchial effects.....	17
Acetylcholinesterase and acetylcholine levels.....	19
Metabolism (Body Disposing of Agent).....	20
Aging.....	21
Current Treatment Procedures.....	22

Lack of human subjects	24
Acute verses chronic.....	26
Problems with scaling from animals to humans	28
PBPK modeling.....	29
III. Methodology	33
Development of the model	33
Overview	33
Dealkalization of the OP	34
Link between the AChE and the ACh.....	35
Specification of Compartments	35
Parameter Values.....	37
Assumptions	38
Methodology.....	38
Sensitivity Analysis.....	38
Sensitivity Analysis Results	40
Inhalation.....	40
Bronchial Scrubbing.....	42
Dermal Exposure	43
Testing Portion	44
IV. Analysis and Results.....	48
Analysis and results.....	48
Inhalation.....	50
Bronchial Scrubbing.....	57

Dermal	60
V. Conclusions	68
Conclusions	68
Future Work	70
Appendix 1	72
Model	72
Appendix 2	90
Model equations	90
Appendix 3	112
Model definition of terms	112
Appendix 4	137
Model differential equations	137
Appendix 5	144
Model parameters for each trial	144
Appendix 6	146
Simulations run for sensitivity analysis	146
Appendix 7	150
Results of sensitivity analysis	150
Appendix 8	155
Simulations run for testing portion	155
Appendix 9	171
Results of testing portion	171
Appendix 10	187
Parameter Values	187
Bibliography	196

List of Figures

	Page
Figure 1. Basic Structure of Nerve Agent	6
Figure 2. Schematic of synaptic cleft	11
Figure 3. Graph of symptoms versus exposure	16
Figure 4. View of bronchial wall segment	18
Figure 5. Schematic of biochemical interactions between Ops and AChE	22
Figure 6. General structure of PBPK model	31
Figure 7. Model of AChE and its reactions	34
Figure 8. Model for ACh	35
Figure 9. Graph showing different parameter values for sensitivity analysis	39
Figure 10. Example of sensitivity report	40
Figure 11. Graphical definition of bronchial scrubbing coefficients used	43
Figure 12. Results of sensitivity analysis for dermal exposure	44
Figure 13. Graphical representation for trials to be ran when testing the model for bronchial exposures	46
Figure 14. Graphical representation for trials to be ran when testing the model for dermal exposures	47
Figure 15. Levels of ACh in the different tissues when examining partition coefficients	52
Figure 16. Levels of ACh in the different tissues when examining inhibition coefficient	54
Figure 17. Levels of ACh in the different tissues when examining aging rates	56
Figure 18. Levels of ACh in the different tissues when examining regeneration rates	57

Figure 19. Displays the rate of change between scrubbing coefficients 1 and 10	59
Figure 20. Displays the ACh levels in different tissues via dermal exposures	61
Figure 21. Displays change in ACh levels with different skin transfer coefficients	62
Figure 22. Demonstration of the buildup of ACh from an extended exposure time	64
Figure 23. Comparing trends using multiple molecular weights with one	67

List of Tables

	Page
Table 1. Nerve agent chemical structure	7
Table 2. Properties of nerve agents	8
Table 3. Reactions to different exposures	14
Table 4. Example of ACh levels in different tissues	53
Table 5. List of organophosphates used in model	65

COMPARATIVE KINETICS AND DISTRIBUTION TO TARGET TISSUES OF ORGANOPHOSPHATES USING PHYSIOLOGICALLY – BASED PHARMACOKINETIC MODELING

I. Introduction

Introduction

Organophosphates have been around for a long time. Pesticides are the most commonly used organophosphates, both residentially and commercially. In the 1940's, chemists in Germany developed organophosphates that were much stronger than the everyday pesticide. These chemists discovered that a country could use these organophosphates as a weapon to create a great deal of destruction, panic, and terror on an enemy. Since that time, many countries have been looking at ways to defend themselves against these select organophosphates.

Background

In the 1900s, the understanding of chemistry exploded in Europe bringing about organophosphate compounds that could be used as effective military weapons. German chemists developed three different agents called tabun, sarin, and soman. After World War II, NATO designated these agents GA, GB, and GD respectively (G standing for German). Two other chemicals designated by initials are VX (V standing for venomous) and GF. Great Britain developed the VX agent and the United States of America was able to weaponize it. The world began stockpiling these deadly agents, or nerve agents, and they began to surface during military conflicts and terrorist attacks against civilian

populations (Costa, 2005, Cannard, 2006). Nerve agents are a colorless, mostly odorless liquid, not a gas, as popular beliefs suggest. A common delivery method is to use an explosion or crop duster to aerosolize or vaporize the liquid into the air (Cannard, 2006). By using this type of delivery method, the enemy can expose the highest number of people possible and create a much larger contamination zone. Achieving the same affects in its liquid form is far more difficult. Putting the agent into the air makes inhalation the most common route of entry to the body.

Due to the adverse affects of organophosphates, human experiments are unethical to conduct. However, there are several instances throughout history where nerve agents have been used on human populations, such as the subway bombing in Tokyo and Matsumoto, Japan. Data can be and has been collected from those samples (Nishiwaki 2001, Yanagisawa, 1995). Currently, the best source showing the effects organophosphates have on mammals comes from experiments performed on laboratory animals. Scientists can then scale those results to the human body (Aurbek, 2006) and make predictions as to how it will react. To overcome the deficiency of human subjects in determining the effects of nerve agents, the use of modeling can be of great help. Physiologically-based pharmacokinetic (PBPK) models show a representation of how organophosphates react with different body tissues. This type of modeling is valuable because it shows the hazards of the different routes of entry, such as inhalation, oral, or dermal (Shelley, 1996). There are limitations to modeling in that, although rats, mice and pigs are all mammalian, their genetic makeup is different from humans. This can cause problems in the scaling process from the animal tests to human kinetics (Cannard, 2006,

Gearhart, 1994). Animal data, however, can give a good indication of how the agents decompose in the body by natural processes (metabolism), the levels of toxicity in the various tissues, and how fast they recover. PBPK models can also overcome some of the scaling problems from one species to another.

Surviving a nerve agent attack is possible. Historical events have given us human experiences with these deadly agents. A good example is the attack in Tokyo, Japan. In this case, 1,050 humans were exposed and only 12 died. The deaths were caused by either acute exposure or hypoxic injury prior to reaching the hospital. The attack was not an ideal scenario; the sarin used was relatively diluted and dispersed in an ineffective manner. This event may not accurately predict future attacks (Cannard, 2006), but does give a level of insight as to how the body will react in a real life situation.

Problem Statement

As service members fight for their country and for the freedom of those in other countries, it is imperative that they return home both mentally and physically healthy. Currently, the United States is fighting in places where the enemy is using more and more innovative weapons (dirty bombs or improvised explosive devices). A soldier being able to protect himself from these types of weapons has become a high priority on today's battlefields. The likelihood that the enemy may obtain a crude type of nerve agent from the many rogue organizations (whether legitimate governments or terrorist cells) around the world is not inconceivable. It is important that these soldiers know the best ways to protect themselves if the enemy obtains and attacks with these agents.

Organophosphates, particularly nerve agents, are some of the deadliest substances on earth. Their effects to the body materialize very quickly, and, if the victim does not receive treatment in a timely manner, serious long-term effects or death can occur. In this study, a physiologically-based pharmacokinetic model is developed to model the effects of exposure. Once this is accomplished, exploration of the model to compare the different routes of entry into the body as well as looking at the levels of acetylcholine that is produced and accumulated in the different tissues groups.

In the case of death, literature agrees that the cause is mainly from respiratory failure due to the paralysis of a combination of the respiratory muscles from acute exposure. Therefore, the bulk of this research will be looking at lower doses of exposure and how they affect acetylcholine levels in specific tissues. The different tissues groups that are incorporated into the model will be the brain, liver, kidney, fat, diaphragm, arterial blood, venous blood, bronchial passages, and the skin. The remaining tissues will be lumped together as either slowly or richly perfused tissues.

Research Question

The main purpose of this study is to answer the following question: *How do the kinetics and the distribution of organophosphates affect the target tissue's level of acetylcholine and what levels of this electro-transmitter cause damage (or symptoms) to the body?*

Investigative Questions

This study will investigate several questions. These questions deal with how the organophosphate is absorbed into the body and what type of effects will be encountered.

- Can a reasonable model concept be formulated to represent OP kinetics relevant to action and toxicological target tissues?
- What are the levels of acetylcholine (ACh) in target tissues as a resulting from different exposure possibilities?
- Does bronchial scrubbing have an effect on how fast the actual concentrations of the tissues reach maximum or steady state levels?
- Does dermal absorption kinetics differ from those of inhalation and if so how fast/slow does it take for the concentrations of the tissues to reach the maximum/steady state levels?
- What trends can be seen (if any) in the ACh levels with the different exposures?

These questions are of particular importance because if answered, they can provide valuable information to those in the field who need decision tools for optimizing available treatments to avoid death and/or severe long-term effects.

II. Literature Review

What are organophosphates

Organophosphates have been around since the 1800s. It was not until the late 1930s, early 1940s when organophosphates were developed and used as insecticides (Costa, 2005). These agents were then further developed as a weapon, whose primary effect is on the central nervous system. These agents are tabun, sarin, soman, and VX. They have been designated as “nerve agents” by NATO, which fall into the class of weapon of mass destruction. Weapons of mass destruction are nothing new, they have been a threat and used since the early 1900s. One of the earliest recordings in the modern era is in 1915 when German forces used chlorine gas on opposing French troops, causing anywhere from 5,000 to 10,000 casualties. The general chemical makeup of an organophosphate or nerve agent (Figure 1 and Table 1) contains a central phosphorous atom bound to an oxygen (or sulfur) atom, two alkyl groups, and a leaving group (Cannard, 2006).

Compounds that contain a sulfur atom require a metabolic bioactivation whereas; compounds that contain a phosphorous – oxygen bond are effective inhibitors of acetylcholinesterase (Costa, 2005). The carbon-phosphorous bond is fairly common to nerve agents but is rarely found in their pesticide cousins (Augerson, 2000).

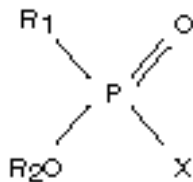

Figure 1. Basic Structure of Nerve Agent. R1 and R2 are the alkyl groups and X is the leaving group.

Table 1. Nerve Agent Chemical Structure

Agent	X	R ₁	R ₂
Tabun (GA)	CN	N(CH ₃) ₂	C ₂ H ₅
Sarin (GB)	F	CH ₃	CH(CH ₃) ₂
Soman (GD)	F	CH ₃	CH(CH ₃)C(CH ₃) ₃
VX	SCH ₂ CH ₂ N[CH(CH ₃) ₂] ₂	CH ₃	C ₂ H ₅

Source: Augerson, 2000

Note: Keyed to Figure 1

There are a variety of organophosphates that will be discussed throughout this study. Each one of them varies in toxicity and properties. Some of the properties are similar (all of the nerve agents are a liquid) and some of the properties vary widely across the spectrum (i.e. LD₅₀ for each agent). Table 2 summarizes the properties of nerve agents, which are highly toxic organophosphates. One of the properties that make nerve agents so much deadlier than typical organophosphate insecticides is that the nerve agents do not allow the required time for bioactivation to take place, which in turn does not provide efficient protection from the endogenous mechanisms. The organophosphate insecticides are much weaker than their nerve agent cousins and they allow enough time for bioactivation, which allows the body to utilize its defenses more effectively (Chambers, 2003).

Table 2. Properties of Nerve Agents

Property	NA			
	Tabun (GA)	Sarin (GB)	Soman (GD)	VX
Description	Clear, colorless and tasteless liquid	Clear, colorless and tasteless liquid	Pure liquid is clear, colorless, and tasteless; discolors with aging to dark brown	Amber colored, tasteless, and odorless oily liquid
Warning properties	Although GA has a slight fruit odor, this cannot be relied on to provide sufficient warning against toxic exposure	None	Although GD has a slight fruity or camphor odor, this cannot be relied on to provide sufficient warning against toxic exposure	None
LD ₅₀ (mg)	1000	1700	50	6-10
LC ₅₀ (mg-min/m ³)	400	100	50-70	10-50
Aging half-time (approx.)	14	5 h	2-6 min	48
Vapor Density	5.6 (air = 1.0)	4.9	6.33	9.2
Solubility in water	9.8g/100g	Miscible	2.1g/100g	3g/100g (miscible below 48.9 °F [9.4 °C])
Volatility	490 mg/m ³ at 77 °F (25 °C)	22,000 mg/m ³ at 77 °F (25 °C)	3900 mg/m ³ at 77 °F (25 °C)	10.5 mg/m ³ at 77 °F (25 °C)

Source: Cannard, 2006

Release Mechanisms

There are several different ways or methods that organophosphates can be delivered in order to cause an individual or group of individuals to become exposed. When an enemy is trying to target a few people, they may use such delivery methods as explosive shells, rockets, missiles, aircraft bombs, or mines (NATO, n.d.). When these weapons are used, the contamination area will be rather small. Depending on the type of munitions used, the agent will be concentrated within a certain radius of the impact point. The radius will have some variation due to wind speeds and how long it takes the agent to disperse into the atmosphere where it is diluted enough to no longer be toxic. Another way to target a few people is by putting the nerve agent in a specific area in its liquid form. This presents more of a dermal threat rather than an inhalation threat, but because of the nature of the agents, specifically VX, it can sit on a surface for hours, days or even weeks depending on the weather (Canard, 2006).

If exposing as many people as possible is the ultimate goal, then the use of spray devices might be the weapon of choice. This is because it can be used in an aircraft with spray nozzles (such as a crop duster) in order to cover people with a fine mist of the chemical. Other ways that large amounts of people can be exposed is by contaminating a community's water supply with chemicals that are water-soluble or miscible liquids or solids (NATO, n.d.). Not only can these agents be delivered by spray in an aircraft, but they can also be spread using something as simple as an aerosol canister or sprayer that mounts to a trailer or bed of a truck. This would allow someone to drive around an area while "pumping" the agent into the air.

It is important to know that because of the nature and makeup of the different agents, they tend to dissipate fairly quickly. This allows rescue personnel the opportunity to reach victims, treat them and move them to a medical facility, giving most individuals an opportunity to get the treatment needed. The successful recovery of patients largely depends on the treatment given in the first couple of hours (Canard, 2006).

How do organophosphates work

Although there are different types of organophosphates and each one varies in its properties, they do have similar effects on the body. Each agent is an acetylcholinesterase (AChE) inhibitor. Once the nerve agent enters the body, the primary target is the body's AChE, which hydrolyses ACh, a major neurotransmitter in the peripheral and central nervous system (Costa, 2005). The inhibition of AChE causes a chain reaction that develops into symptoms, which can be easily seen throughout the body.

Having a basic understanding of the cholinergic receptor types and their locations is needed to properly understand how the enzymes work naturally and to be able to distinguish the difference once an organophosphate (or nerve agent) attacks them. The muscarinic and nicotinic receptors are the two primary types of cholinergic receptors. The muscarinic receptors are found on the targets of parasympathetic neurons, which primarily innervate smooth muscles and exocrine glands. The tissue groups where the muscarinic receptors can be found are around the eye, tear ducts, nasal and salivary glands, the heart, gut, and the bladder (Cannard, 2006). As the nerve cell releases ACh from its presynaptic side, the stimulation of the nicotinic receptors of the neuromuscular junction occurs on the post synaptic side of the next nerve cell “in line” (See Figure 2). The presynaptic release takes place when the potential for movement occurs. These nerves branch out to innervate many muscle fibers and essentially contract at the same time causing the desired movement (Cannard, 2006).

The body uses ACh and AChE constantly and is essential for life to exist. The brain sends an electrical pulse through the different nerve cells throughout the body. Each nerve cell is independent of each other (they do not touch). Those cells are lined up and in order to send signals to each other, they must have a way to effectively communicate across the synaptic space (space between each cell). As shown in Figure 2, once the cell receives the electrical pulse and this pulse reaches the presynaptic side, ACh is secreted into the cleft. The ACh then quickly travels across the approximately 50nm of space to the postsynaptic side of the cleft. Here it binds and within 100 μ s the pulse is past on to the next nerve cell. In order to stop the ACh from constantly sending the

signal over and over again to the next cell, the ACh must be removed in order to return the site back to its pre-bond form (Calvert, 2002).

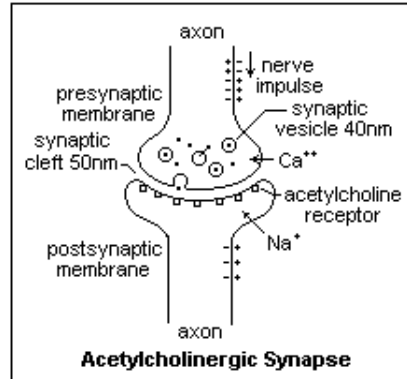

Figure 2. Schematic of synaptic cleft

The way the nerve “resets” itself on the postsynaptic side is by using the enzyme AChE. This enzyme contains a serine residue that allows it to bind with the ACh. It then continues to hold onto the acetyl portion of the acetylcholine and allows the choline portion to be released back into the synaptic cleft. This separation of the acetyl group and the choline occurs in about 40μs. The AChE then gets rid of the acetyl through hydrolysis and then the AChE is ready to start the process over. With the rate that the AChE can handle ACh, a normal synaptic cleft can handle anywhere up to 1000 impulses per second (Calvert, 2002).

Once in the body, independent of method, organophosphates do not attack the nerve cells, as to popular belief. The organophosphate will attach itself to the AChE enzyme, which will stop AChE from doing its job of separating the acetyl from the choline and ceasing further unwanted electrical pulses traveling down the nerve “chain.” Nerve agents create a strong bond with the residue of the AChE which prevents

hydrolysis from taking place (Zoltani, 2000). Once the AChE is rendered inactive, a buildup of ACh in the synaptic cleft will follow because the receptive state of the postsynaptic membrane cannot be reestablished, resulting in cholinergic effects throughout the body (Maxwell, 1986; Calvert, 2002). The only way to reduce the symptoms naturally is by either reactivating or creating new AChE, because this is the sole way that ACh can be disposed (Costa, 2005). This statement may only apply to Costa's time horizon and may not apply to the model being studied in this paper.

Symptoms

As mentioned above, as AChE is inhibited, symptoms will begin to develop. The type and severity of the symptoms is dependent on the exposure level of the victim. Was the person exposed to a high concentration for a short amount of time or low concentrations for a long duration of time? Symptoms are also dependent on where the nerve agent is concentrated throughout the body. Is it localized in one area or is it wide spread among the body? An exposure from an organophosphate will affect both the muscarinic and nicotinic receptors throughout the body. The muscarinic receptors innervate intraocular muscles, lacrimal and nasal glands, salivary glands, bronchial muscles and glands, the heart, muscles of the gut and the bladder. The symptoms that are associated with these receptors after an exposure are miosis, with dim or blurred vision, eye pain or headache, tearing, rhinorrhea, salivation, bronchoconstriction and excessive respiratory secretions with dyspnea, bradyarrhythmias, hypotension, nausea and vomiting, abdominal cramps, diarrhea and bowel incontinence, or urinary incontinence.

Nicotinic receptors are found in several places throughout the nervous system. They are in the sympathetic and parasympathetic nervous systems, in the neuromuscular junction of the somatic muscle, and some are in the central nervous system. The regular functions of these receptors are to allow the simultaneous contraction of a hundred plus muscle fibers in order to allow movement. After a nerve agent exposure and the build up of ACh occurs, fasciculations of individual fibers result rather than the coordinated contractions of the entire unit. Without the presence of AChE, these fasciculations will progress to fatigue allowing paralysis to quickly follow. In the parasympathetic system, both the muscarinic and nicotinic receptors are found, and they are lined up in series. This results in symptoms from both types of receptors. This amplified effect of the parasympathetic output may be the reason that symptoms are predominate in nerve agent intoxication and why it is the parasympathetic symptoms that predominate in milder exposures (Cannard, 2006).

Each type of exposure will cause a variety of symptoms to occur. When looking at a mild inhalation poisoning, the symptoms that will develop within seconds to minutes after exposure are, but not limited to, the following: miosis, dim vision, headaches, rhinorrhea and excess salivation. As the poisoning becomes more severe, the symptoms will become steadily worse. A severe vapor exposure will add severe breathing difficulties, and generalized muscle twitching. If an individual is exposed to liquid on their skin, the symptoms will vary slightly. A mild/moderate exposure will produce localized twitching and vomiting, and the onset occurs within ten minutes to 18 hours after exposure. A severe case will add convulsions and loss of consciousness. Onset is

also a lot shorter for severe cases in that symptoms will appear minutes to an hour after exposure (USAMRICD, 2000). Table 3 shows a more complete list of what to expect when exposed to nerve agents.

Table 3. Reactions to Different Exposures

Type of Exposure	Symptoms	Time of Onset after exposure
Vapor		
Mild	Miosis, Dim Vision, Head Ache Rhinorrhea, Salivation, Dyspnea	Seconds to Minutes
Severe	Above plus: Severe breathing difficulty Generalized muscle twitching, weakness or paralysis Convulsion Loss of consciousness Loss of bladder, bowel control	Seconds to Minutes
Liquid on Skin		
Mild	Muscle twitching at site of exposure Sweating at site of exposure Nausea, vomiting	10 minutes to 18 hours
Severe	Above plus: Severe breathing difficulty Generalized muscle twitching, weakness or paralysis Convulsion Loss of consciousness Loss of bladder, bowel control	Minutes to an hour

Source: USAMRICD, 2000

If treatment is not given, the symptoms described above will continue to worsen and can become fatal. The credit for death comes from respiratory failure due to a combination of effects from the central and peripheral nervous systems, specifically bronchoconstriction, enhanced bronchiolar secretions, paralysis of the respiratory muscles, and shut-down of the respiratory control center in the brain (Chambers, 2004, Maxwell, 1988). With the onset of symptoms starting as fast as seconds after exposure, action to curb the effects of the nerve agent is paramount.

Poisoning by nerve agent can be identified by the characteristics and symptoms described above. If the exposure was cutaneous or ingested through food or water, the

pupils may appear to be normal. If this does occur, then one must rely on the other manifestations of nerve poisoning in order to determine exposure. There are no other known chemical agents that produce the type of symptoms that nerve agents produce (Federation of American Scientists).

Figure 3 shows an example of a list of symptoms that can be experienced when given a dose of sarin gas. The three exposures that were used in this experiment are 0.00117 milligrams per liter of air (this represents 70 mg-min/m³ at 60 minutes), 0.00058 milligrams per liter of air (this represents 70 mg-min/m³ at 60 minutes), and 0.00003 milligrams per liter of air (this represents 2 mg-min/m³ at 60 minutes).

Effect of different organophosphates

Several studies have compared the effects of organophosphate insecticides on AChE in both mammalian and non-mammalian species. Even though the insecticides inhibit AChE, they are far less potent than nerve agents (Gray, 1987). Organophosphates can cause many different problems in the body. Meggs (2003) gives an example of how fast and what some of the long term issues are for a dermal/inhalation exposure to the organophosphate insecticide chlorpyrifos. This insecticide is an intermediate organophosphate in its ability to inhibit esterase. The result from the exposure was permanent paralysis, weakened grip, inability to urinate, and loss of motor control.

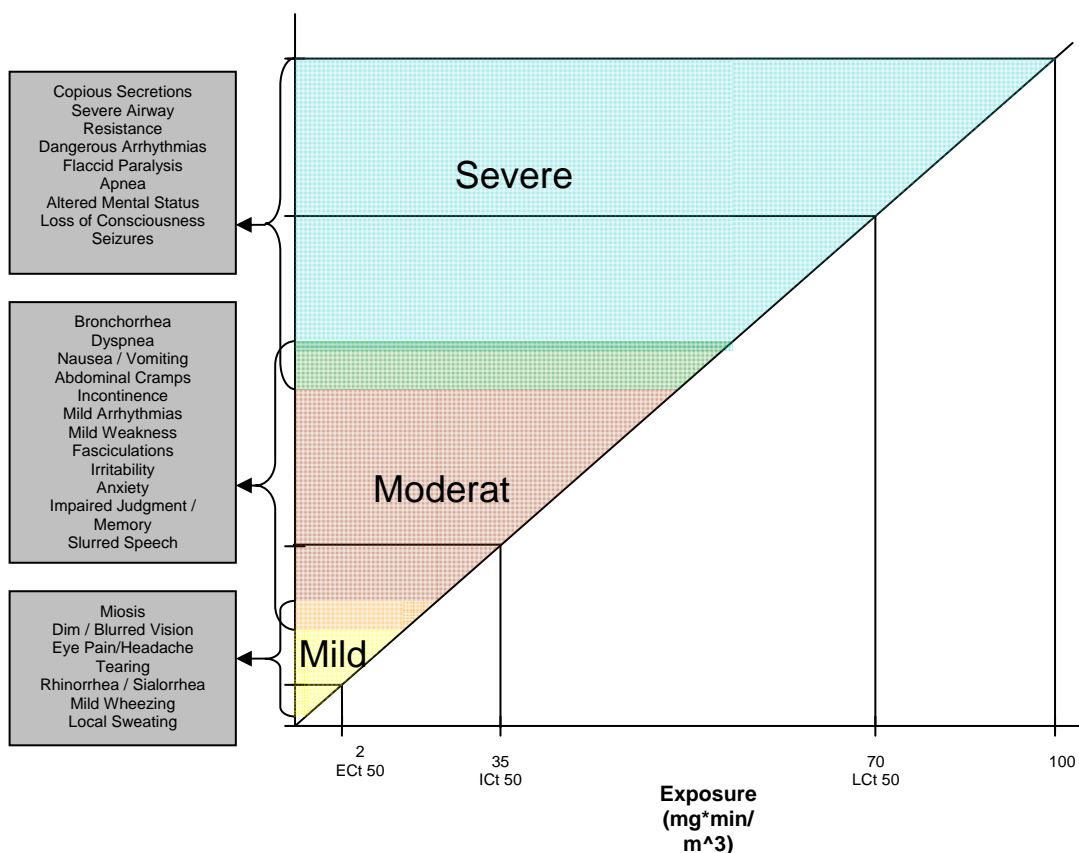

Figure 3. Symptoms one may experience when exposed to different levels of sarin (USAMRICD, 2000, Federation of American Scientists, 2006).

When examining the affect of the more intoxicating nerve agents, one can see the problems that can develop when an exposure occurs. As the nerve agent begins to infect the entire body, the blood flow to certain tissues begins to slow down. This effect can be seen in the kidney, spleen and the skeletal muscle (Maxwell, 1986). Examining the toxicities of soman on the body resulted in an inhibition of up to 80% of the AChE in plasma, lung, brain and the heart. AChE inhibition was not as detrimental in other tissues such as the diaphragm, hind limb skeletal muscle, kidney and spleen. The inhibition in these tissues ranged from 30-60%. The liver and intestines were virtually uninhibited,

with the AChE levels dropping to only 97% of normal (Ibid.). Maximum inhibitions of AChE in all tissues were achieved in 16 minutes (Maxwell, 1988).

Other studies looking at sarin describe that low doses will cause an increase in the resistance in the airway (Sopori, 2006) making it difficult to breathe. Hypoxia can then occur because of cholinergic stimulation, increased secretion, bronchospasm, and weakened respiratory muscles (Meggs, 2003). Although hypoxia may develop, it doesn't mean that the blood flow throughout the body is decreasing. This is true in some tissues, but the exact opposite in others. The blood flow to the brain, heart and lungs actually increased anywhere from two to four times the normal rates. Blood flows also decreased up to 50% in other tissues such as the kidney, spleen and the skeletal muscle.

There are several other areas of the body affected by nerve agents that are not mentioned above. After an exposure, the gastrointestinal tract will have an increase in motility and secretions by the gland walls will begin. Nausea and vomiting are also early signs of liquid exposure. Diarrhea can occur from a large exposure. The different bodily glands will increase their secretions when in contact with a nerve agent, and the skeletal muscle will begin to twitch. After a large amount of agent enters the body, fatigue and weakness of muscles are rapidly followed by muscular flaccidity (USAMRICD, 2000).

Bronchial effects

As noted above, the airway is greatly affected when an exposure takes place, especially when it is a vapor exposure. The bronchial passages can help reduce the amount of agent that is introduced into the blood stream by the alveolar blood-gas

exchange. The process that takes place inside the bronchial passages is called “scrubbing.”

Starting with the trachea and extending down to the alveolar spaces are thousands of bifurcating airways in which the air travels through the lung to the air-blood exchange. These airways vary in size and length. They get smaller as they progress from one generation to the next. Inside these airways (before reaching the air-blood exchange) is where the “scrubbing” takes place. There are two liquid layers that coat the inside wall of the bifurcating airways. There is a thinner water layer directly adjacent to the wall and a thicker glyco-protein layer on top of the water layer. Ciliated cells line the epithelial wall, which extend through the water layer into the glycol-protein layer which can be seen in Figure 4. These ciliated cells are in constant motion (Shelley, 1996).

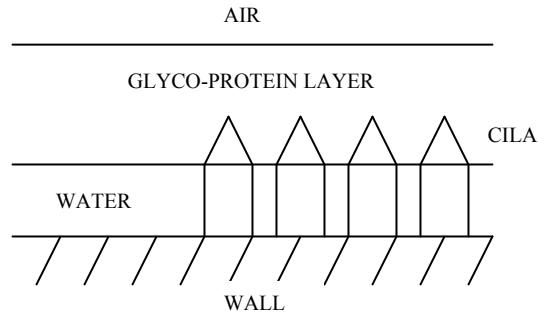

Figure 4. Longitudinal view of bronchial wall segment-liquid layers lining the inside to air flow (Shelley, 1996).

Scrubbing occurs once particulate matter has been inhaled. The ciliated cells lining the epithelial wall move the glyco-protein layer upward through the bronchial passages. Inhaled particles stick to the glyco-protein layer and with the upward movement of the fluids, the particle is transported to the trachea where it is disposed of in the gastrointestinal tract (Shelley, 1996). In the case of gaseous vapors being inhaled,

when the molecules are captured and absorbed, they would continue to pass into and out of the various fluid or tissue regions depending on the prevailing concentration gradients and the diffusivity of the chemical (Shelley, 1996). An example of this is that if an organophosphate has a lot of particulate matter and the gaseous molecules have the ability to be absorbed into and out of the tissue regions there is the possibility to have a high scrubbing rate. If the organophosphate has few particulates and the gaseous molecules cannot pass through the tissue regions before reaching the blood – gas exchange, very little scrubbing will take place.

One item to note is that the bronchial tissue is a direct route for the organophosphate to enter the bloodstream. Once the chemical molecules begin to infiltrate the tissue of the bronchial walls, the chemical will then be transferred to the blood via the tissue blood exchange. This will increase the concentration within the blood (Shelley, 1996) and ultimately the different tissues throughout the body.

Acetylcholinesterase and acetylcholine levels

Acetylcholine (ACh) is vital for body function. Having too much creates symptoms associated with organophosphate exposure. Keeping this transmitter under control is paramount, if it is allowed to build up, death can occur. ACh is found in the peripheral and central nervous systems to assist in the process of cellular communication (Aidoo, 2006).

There are many different mechanisms that attribute to determining the concentration, release, and distribution of ACh into the synaptic cleft. Some of these factors include the number of vesicles releasing ACh, the location of these vesicles,

geometry of the cleft, and AChE hydrolysis. Most of which have not been studied qualitatively or in much detail (Aidoo, 2006).

In order to obtain results as accurate as possible, a release rate is required. According to Aidoo (2006), ACh has been modeled as a continuous release function. Of the thousands of ACh molecules that reach the post-synaptic side of the nerve cell, only about 2/3 of the ACh actually activate the receptors, since each receptor requires two molecules to open the receptor channel. Thus, allowing the electric signal to continue down the “nerve chain.” The other ACh molecules that don’t activate the receptors are hydrolyzed by AChE. Of all molecules released into the synaptic cleft, only about 1/5 actually bind to the post-synaptic side to open receptor channels. This leads to an initial concentration of approximately 300 mM.

Metabolism (Body Disposing of Agent)

There are a couple of ways that the body is able to dispose of an agent that it has been exposed to, therefore allowing the body’s natural processes to return to normal. One of the ways that the organophosphates are removed from the body is by the process of aging, as described in a latter section. A chemical change takes place when an organophosphate ages to an AChE molecule (Canard, 2006). At this point the chemical can no longer be released into the body to cause additional toxic effects. A second method that can remove organophosphates from the body is that of bronchial scrubbing. This is also described in a previous section, but allows the foreign particles to be moved from the trachea to the GI tract (Shelley, 1996). This action helps to prevent the agent from moving into the blood stream, or at least slow it down.

A third way that the body can remove the agent is by breathing. This occurs with the blood-gas exchange that takes place in the lungs. Assuming that the individual has been removed from the “danger area” and is no longer taking in any chemical, the agent will be transferred back into the trachea and removed by exhaling (Shelley, 1996). One last method that the body can remove organophosphates is by metabolism. This process mostly takes place in the liver, but several other tissue groups have the capability to do so (Gearhart, 1994).

These processes are imperative in order for the body to “heal” itself. There may be other precautions that are needed in order to help it do so, like administering atropine. If the body has no way of disposing of the agent, then it would be difficult to stop the symptoms from occurring, which could result in a higher death rate.

Aging

One issue that an individual needs to remember when dealing with a victim poisoned with an organophosphate or nerve agent is a concept called aging. As the nerve agent begins its process of inhibiting AChE from doing its job of hydrolyzing ACh, one of two things can occur. The enzyme will return to its free pre-inhibited form and return to hydrolyzing ACh or it will “age” and form a permanently inhibited enzyme (Gearhart, 1994). If aging occurs, the only way for the body to replace the now useless AChE enzyme is by producing more. This process can take up to several days to accomplish (Costa, 2005), and, by then, permanent chronic effects or death can occur. This occurs because once the organophosphate attaches itself to the AChE enzyme, the leaving group will break off of the organophosphate, which varies from agent to agent (see Table 1). If

nothing is done to dissociate the organophosphate from the AChE, the bond will mature and become permanent. Aging occurs by the stabilization of the nerve agent-AChE complex when dealkylation, the removal of an alkyl group, occurs. This process can develop anywhere from 2 minutes up to 2 days (Cannard, 2006). Figure 5 shows a general schematic of how these reactions happen.

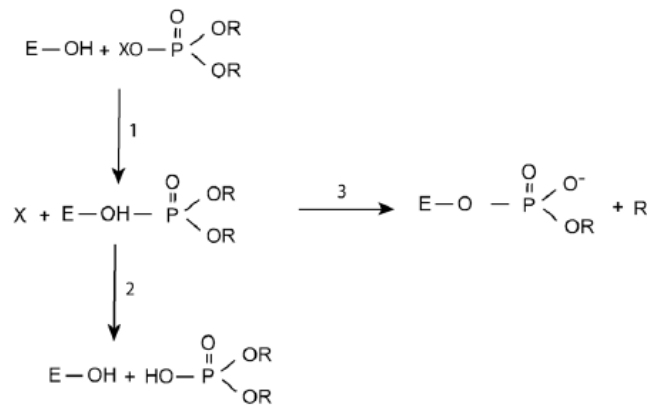

Figure 5. Schematic representation of biochemical interactions between Ops and AChE. Reaction 1 leads to phosphorylated AChE. Reaction 2 is spontaneous reactivation of AChE. The rate of this reaction can be accelerated by oximes. Reaction 3 is the aging and leads to a stable, negatively charged phosphorylated AChE. E-OH, active site of the enzyme. Source: Costa, 2005

Current Treatment Procedures

There are several ways to treat an individual who comes in contact with organophosphates. Obviously, the best way is to not get exposed by the proper use of protective equipment. However, in a wartime situation, there may not be enough time to adequately provide that protection before an exposure occurs. If the exposure does occur, there are three possible methods of treatment. When treating someone, most of the time, more than one method will be used together. These methods are pretreatment, the use of medication, and decontamination.

There are other enzymes in the body that organophosphates will target besides AChE. These enzymes are carboxylesterase (CaE) and butyrylcholinesterase (BuChE). An important issue about these enzymes is that when they bind with an organophosphate there are no toxic effects in the body (Maxwell, 1988). Prophylaxis with BuChE helps to neutralize the organophosphate before it reaches target tissues and inhibits AChE. In order to neutralize the organophosphate, enough BuChE would have to be present in the body to be able to reduce the organophosphate by half within ten seconds in order to protect the individual from severe toxic onset (Chambers, 2004).

Even though the levels of BuChE can be easily increased with an injection on the battlefield, there are several drawbacks that do not make this procedure very effective. The injection would have to be administered at the correct time or it will be unsuccessful. If the injection of the BuChE is too early, it might be ineffective, if the individual waits too long, they may be incapacitated before they can administer the injection. Also, the individual would have to have some sort of knowledge about how much nerve agent the enemy is planning on using to be able to use the correct amount or it will also be rendered ineffective. There are also concerns about repeated doses causing problems with the immune system (Chambers, 2004).

There are three different types of medication that are used in treating individuals for organophosphate exposure. The first is anticholinergics. Atropine is the typical anticholinergic (antimuscarinic) used for organophosphate effects. Atropine, once administered, competitively and reversibly blocks the binding of ACh to the muscarinic receptor sites. It needs to be noted that atropine does not affect the nicotinic receptors

(Cannard, 2006). This is important because symptoms that are associated with the nicotinic receptors (i.e. fasciculations) will continue to persist after the treatment is given. Therefore, focus should be kept on the symptoms related to the muscarinic receptors before deciding to administer additional atropine.

Oximes are also very common for treating individuals intoxicated with a nerve agent. Oximes act to reactivate any AChE that has been inhibited by an organophosphate. It acts like a crowbar, by prying the chemical off of the enzyme allowing the AChE to return to hydrolyzing ACh. If aging has occurred, then any oxime will be rendered useless. As mentioned previously, aging is permanent and can not be reversed. In order to reduce the likelihood of aging, an oxime should be administered as soon as possible after exposure (Ibid). The third medication is the use of anticonvulsants. This is taken to reduce convulsions that are in connection to the exposure. Diazepam is the medicine of choice. Mortality rates have been reduced in experiments with animals treated with diazepam, especially when used in combination with atropine (Ibid).

The third portion to treating personnel contaminated by a nerve agent is decontamination. This step is imperative, because if not done, many more individuals will be exposed to the nerve agent, including the health care provider. Thoroughly flushing with water will dilute the nerve agent's concentration, depending on the agent, making it a relatively nontoxic compound (Cannard, 2006).

Lack of human subjects

Due to the fact that nerve agents pose a risk to the health of humans, it is not ethically or humane to do tests on human beings. This causes a dilemma in trying to

discover how organophosphates react with the body as well as the best methods to stop any symptoms from occurring. There are a few cases in which researchers are able to get some information where there has been a nerve agent exposure to the human population. These are few and far between, but do exist.

One example is the attacks in Japan. The first attack occurred in Matsumoto on June 27, 1994. This was a presumed terrorist attack and approximately 600 personnel were poisoned. Fifty eight of these people were admitted to the hospital and seven died. The clinical and laboratory findings were examined on 264 people who sought treatment. For those who were severely poisoned, there was a decrease in serum cholinesterase, AChE in erythrocytes, serum triglyceride, serum potassium and chloride, and an increase in serum creatine kinase, leucocytes, and ketones in urine. The good news is that there were no persistent abnormal physical findings in any of the people examined. AChE levels also returned to normal after 3 months (Morita, 1995).

A second sarin attack in Japan happened about a year later on March 20, 1995. This attack occurred in the subway system in Tokyo. It was a much larger attack than the one that occurred in Matsumoto. More than 5,500 people were poisoned and 12 individuals were killed (Nishiwaki, 2001). This provided researchers another opportunity to learn more about the actual health effects of nerve agent poisoning among humans. Nishiwaki (2001) tried to clarify what the chronic effects (if any) of the exposure is, three years after the poisoning took place. One of the tests they performed suggested that there were memory problems, but further study was needed.

Another example of an organophosphate poisoning can be found in Meggs (2003) paper on the paralysis of an individual due to dermal exposure. By the simple application of a “termite killer” (which was an organophosphate) without using the proper safety precautions, such as mask, long pants, shoes that covered the feet, etc., the individual found himself in the emergency room with signs of organophosphate poisoning. This particular individual ended up having permanent loss in strength in his hands and in one leg and could not urinate without catheterization.

Researchers are beginning to look at what happened to the U.S. service members who are being diagnosed with Gulf War Syndrome. It is believed that sarin gas is the root cause of this diagnosis. It is now being reported that over 300,000 American troops have been exposed to sub-lethal doses of the gas. Some of the chronic long term effects are that some soldiers have 5% less white brain matter (connective tissue) than soldiers who were not exposed. There was also evidence that those individuals who were exposed had lost approximately 20 years with their fine motor skills. Other long-term symptoms experienced were chronic fatigue, muscle weakness and fibromyalgia (Kennedy, 2007).

Acute verses chronic

The near term effects of high exposure to chemical warfare agents are well documented. These studies show how potent and fast organophosphates inhibit AChE once the nerve agent enters the body and how these exposures can be lethal. However, the effects of low-level exposures have not been studied nearly as much. There are research gaps in understanding the toxicological effects of low-level exposure to

chemical warfare agents (Genovese, 2004, Henderson, 2002). Genovese (2004) defines a “low-level” exposure as one that is asymptomatic or produces only mild symptoms without producing overt signs of clinical toxicity such as convulsions. Henderson (2002) also states that it is vital that the exposure level used should avoid inducing clinical symptoms.

One group of individuals repeatedly exposed to an organophosphate insecticide similar to sarin is farmers. Some of the symptoms that have been reported from these chronic levels of exposure tend to be along the lines of neuropsychological effects such as giddiness, floating sensations, speech difficulties, memory defects, insomnia, concentration difficulty, mental confusion, anxiety, and emotional lability. Studies have also shown that individuals exposed in an occupational setting have also had persistent neurological damage (Henderson, 2002).

This is a good place to start when looking at what the effects of low-level exposures cause and what symptoms may be expected. This presents a problem when trying to examine a soldier returning from war who may have been exposed to nerve agents. Soldiers did experience the same type of exposure conditions as those described above. They were probably only exposed to subclinical doses once or at most three or four times before their tour was over and they returned home (Henderson, 2002).

Another example that more closely fits the scenarios that are likely to happen on the battlefield is when the terrorists used sarin in Matsuoto and Tokyo, Japan. A study provides evidence that long term muscle, nerve damage, and other central nervous system and neurobehavior effects are a result of the exposures (Wilson, 2005).

When comparing two separate studies that look at low-level exposures to sarin, it would appear that they contradict each other. In evaluating the performance effects, Genovese (2004) suggests that asymptomatic exposure (i.e. non-conclusive) to chemical warfare agents can produce small cognitive and general performance deficits in rats, but these deficits were small and the recovery was relatively rapid and complete. Also, there was no evidence of delayed onset. This suggests that a full recovery is possible following the exposure in relation to performance. Now, when comparing these results with Henderson's (2002) study of the response to rats at low level exposure, they appear to be the exact opposite. It is suggested here that repeated exposures to low-level doses resulted in delayed development of brain alterations that could be associated with memory loss and cognitive dysfunction.

Problems with scaling from animals to humans

One of the major difficulties in studying organophosphates (especially the stronger nerve agents) is not being able to conduct *in vivo* tests. Due to ethical problems scientists face, toxicity studies are seldom conducted with humans. Because of this dilemma, the test subject ends up being a laboratory animal (Leung, 1995). By performing the tests on laboratory animals, *in vivo* testing becomes possible. Researchers are able to study and determine how the animal's body is actually reacting. This however, presents another problem for researchers. How does the kinetics of the animal differ from that of the human and what differences can one expect to see in the human with the same type of exposure?

Leung (1995) explains how this relationship is dealt with and some of the problems or issues when making comparisons. Historically, researchers use body size in order to extrapolate information from one species to another. Basically the administered dose is scaled by using a ratio of the body weight or the body surface area. This method treats the human as nothing more than a large rodent. This does cause some issues of unreliability of how accurate the extrapolation is because it does not take into account the pharmacokinetic differences in the two species. The human is simply not just a large rodent.

This is where using PBPK models help to remove or filter some of the inaccuracies described above. The model interspecies extrapolation is based on tissue dose rather than administered dose. The model takes the administered dose and transforms it into a target tissue dose. If there is not enough information on the pharmacodynamics of the tissues, then it is assumed that the human tissue is similar to that of the rodent (Leung, 1995). The PBPK model is also advantageous over treating the human body as a large rodent because it provides a simple means to explore and examine different types of exposure scenarios and how the human body will react to the different organophosphates.

PBPK modeling

Physiologically-based pharmacokinetic (PBPK) modeling has been around for several decades. Before the mid 1970s, its primary use was in the pharmaceutical arena. It was not until 1974 that these models were extended to analyze environmental chemicals. These models really became popular about 10 years later, when the styrene

model was published in 1984. Over 50 models have been developed to date using environmental chemicals (Leung, 1995). PBPK models are used for several different applications, the most common being that of dose extrapolation. This is done by modeling high-to-low doses, going from one type of exposure to another and from laboratory animal to human. A second practice of PBPK models is in route to route extrapolation which is based on the total administered dose (Leung, 1995). PBPK models have developed into useful tools which allows for the interpretation of pharmacokinetic data (Gearhart, 2005).

The models are generally quite simple to construct. They represent the mammalian system in terms of specific tissues or groups of tissues which are all connected by the arterial and venous blood flow (Figure 6). They are set up in such a way that a series of differential equations are used to describe the mass balance at the different tissues throughout the model (Langenberg, 1997).

PBPK models have three vital components that must be present in order for them to work properly. The first is a species specific set of physiological parameters. This includes such things as organ weights and blood flow values for each tissue group to be studied. Most of this information can be gathered from published literature or obtained from the closest species of study. The second component is chemical specific parameters. These parameters are unique for each chemical and deal with tissue solubility (partition coefficients), metabolism, and the plasma/tissue binding characteristics. The third component that a PBPK model must have is a specific experimental protocol (Gearhart, 2005, 1994).

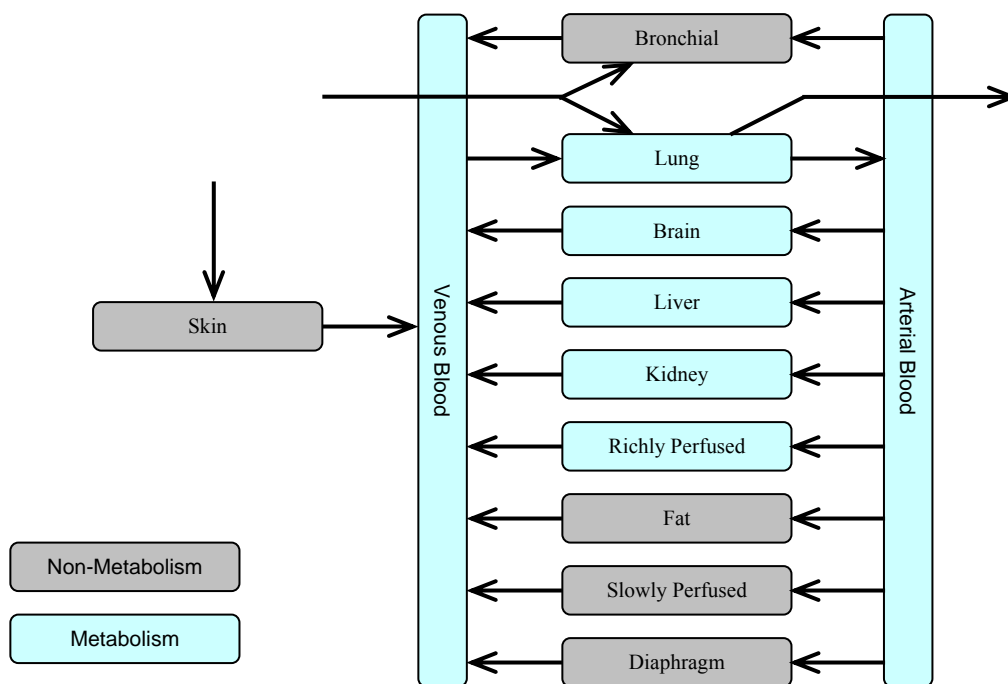

Figure 6. General structure of the PBPK model being used for this study.

PBPK models provide a powerful tool for scientists to observe the effects of a chemical on the body. This could not otherwise be done because of the ethical issues involved with experimentation on live human subjects. Since experimentation can be conducted on animals, PBPK models can be used as a method for extrapolating between different species by using the parameters for that species in question (Sweeny, 2006). A model must be capable of three key outputs. One, predicting the relationship between the organophosphate in question and the toxic effects that the organophosphate delivers to the body; two, be amenable to cross-species scaling; and three, accurately predict outside the dose range over which its primary validation studies were conducted (Gearhart 1994). Sweeny (2006) states that one of the strengths of the PBPK model is in its ability to extrapolate to new species with confidence.

These models have been used in a variety of different aspects. According to Leung (1995) they can be used to estimate the dose-effect data over a wide range of exposure conditions and if validated can be an accurate predictor of outcomes for exposure conditions that have not been experimentally tested. This falls right in with what Gearhart (1994) was stating that a model should be able to do. PBPK modeling typically address long term exposure scenarios, where the tissue concentrations throughout the body are approaching equilibrium (or saturation) with the outside exposure concentrations (Shelley, 1996). By studying these different scenarios and model outputs, scientists can actually make adjustments to regulatory workplace exposure standards as well as giving the capability to study a trickle effect on how an exposed individual may affect another person who was not in the contaminated zone (Shelley, 1996). PBPK models are also used to simulate multiple exposure routes (such as inhalation and dermal), make rational predictions of the disposition of a chemical and to visualize, validate, predict, and hypothesize xenobiotic uptake, distribution, metabolism, and excretion throughout the body (Gearhart, 2005, Leung, 1995, Shelley, 1996).

When putting all of the information together, the PBPK model becomes the tool of choice when conducting a study on chemical uptake in the body. This is where the power of the model lies. By using these time based simulations, scientists and decision makers can better estimate actual chemical doses (Gearhart, 2005) for people who actually experience an exposure, whether by accident, applying an insecticide to a yard or from being attacked by nerve agents on the battlefield.

III. Methodology

Development of the model

Overview

The model is set up as a basic physiologically-based pharmacokinetic (PBPK) model. There are several compartments representing different tissues (Figure 6). The tissues are all separated from one another and are connected via the arterial and venous blood flows. This model examines how acetylcholine reacts to the inhibition of acetylcholinesterase by organophosphates. Several processes take place throughout the model. One is the flow of the organophosphate throughout the body. Once the chemical enters the body (by inhalation) it enters the lungs and, via the blood-gas exchange, enters the bloodstream which then sends it throughout the body to the different tissues. A second process is the metabolism of the organophosphate. This reaction is governed by Michaelis-Menten kinetics (Gearhart, 1994). A third process is the inhibition of AChE by the organophosphate binding with the enzyme and keeping it from reacting with the ACh. The fourth process inside the model is the hydrolysis of ACh by AChE. The model also examines the effect of butyrylcholinesterase and carboxylesterase, which also react with the organophosphate compound. These enzymes actually help because when the organophosphate binds to these enzymes the body does not experience a toxic effect, which then reduces the amount of organophosphate that can bind to AChE.

Once the organophosphate enters the body (either by dermal or vapor exposure), it will enter the blood flow and then be distributed throughout the body. Each tissue

compartment is built in the same manner. As the concentration accumulates in the tissue, a first order inhibition rate occurs with the amount of AChE available in the tissue.

Dealkalization of the OP

To determine the amount of free AChE, one must analyze the concentration of the nerve agent and four different rate constants. The basal level of AChE in each tissue results from a balance between normal degradation of AChE and the synthesis of new enzymes. After exposure occurs, the balance between the bimolecular rate of inhibition and the rate at which inhibited AChE can regenerate itself governs the amount of free (uninhibited) AChE in the tissue. Once the enzyme is inhibited, it will either return to free AChE or it will age and form a permanently inhibited enzyme. Figure 7 shows these relationships (Gearhart, 1994).

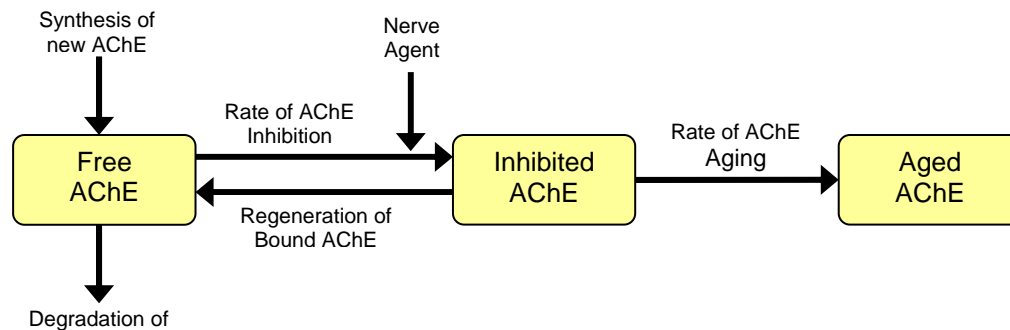

Figure 7. Model for acetylcholinesterase (AChE) inhibition, aging, regeneration, synthesis, and degradation (Gearhart 1994)

The synthesis (or natural creation) rate is defined as a zero order and the rates of inhibition, regeneration, and aging are defined as first order rates (Gearhart, 1994).

Link between the AChE and the ACh

Once the organophosphate has inhibited the AChE, there is not a way to hydrolyze the ACh the body produces; this causes a build up in the synaptic spaces and at the muscle or gland junction. If this buildup becomes too large, symptoms of organophosphate exposure will begin to be apparent. Figure 8 shows the model for the buildup of ACh. The synthesis or natural production of ACh is defined by a zero order rate and the hydrolysis of the ACh is defined by a first order rate.

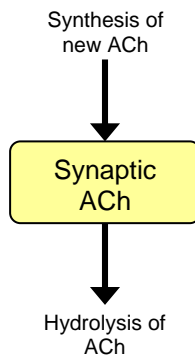

Figure 8. Model for acetylcholine synthesis and hydrolysis.

Specification of Compartments

The PBPK model contains specific tissues (examples: the brain and liver) as well as tissue groups (richly and slowly perfused tissues) (Figure 6). The specific compartments describe the tissues that are directly related to the organophosphates, or those tissues that need to be examined for any reaction to the agent specifically. The tissue groups also comprise all the other tissues in the body that are not specifically mentioned in order to obtain a complete physiology of the mammalian body and to maintain mass balance (Gearhart, 1994).

The fat compartment is different than the other compartments in the model. This particular tissue group does not have any AChE, BuChE, or CaE reactions and there is no ACh built into this portion of the model because the values of these items are so low that they are ignored. This can be seen in the literature in that nobody uses these parameters in their models (Gearhart, 1994, Gentry, 2002, Maxwell, 1986).

The blood compartments are not target tissues per say, they are an important part of the model which performs metabolism and allows us to understand what the organophosphate is doing in not so easily sampled parts of the body. The tissues that have the ability to metabolize the organophosphates (brain, liver, kidney, and richly perfused tissues) do so according to Michaelis-Menten kinetics (appendix 10). The model is run on STELLA 8.0 software by High Performance Systems, Inc. Each compartment has a set of differential equations that defines the mass balance for the amount of organophosphates in the system, the amount of free and inhibited AChE, and the amount of ACh the tissues contain. These equations are in appendix 4.

These two compartments were constructed differently than the others due to their behavior. The blood components of the model do not have the capacity to store the organophosphates that enters the body. Several equations were developed that “remove” organophosphates by simulating the binding to the different enzymes (AChE, BuChE, and CaE). An issue with setting up the blood compartments in this way is that the actual levels of the three enzymes always stay at their initial pre-exposure level. This will skew the actual amounts of the organophosphate metabolized or bound with enzymes

circulating throughout the body. This amount is small enough to press forward with the study.

Parameter Values

The PBPK model requires many different parameters in order for it to work properly and mimic the physiological nature of the body it represents, in this case, a mammalian body. A majority of the parameters used in this particular PBPK model are found from different sources of literature (appendices 5 and 10). Several of the values were not found for specific organophosphates, and, therefore, an analysis was performed. This is explained in the sensitivity analysis below. Some of the parameters include synthesis and degradation rates, volume of tissue groups, blood flows, and hydrolysis coefficients.

Developing the parameter values for ACh is a difficult task to accomplish. There are only a few values that are needed in this model. These are: the AChE hydrolysis rate of ACh, concentration of tissue AChE, tissue volume, concentration of tissue ACh, and the tissue ACh release rate. The concentration of AChE is calculated by dividing the amount of AChE in each specific tissue by that tissue's volume. The same process is used to calculate the ACh concentration. Finding the hydrolysis rate and the release rate, however, are much more difficult. For this model, the initial amount (steady state) of ACh present is 0.100 nmols (Potter, 1970).

The hydrolysis rate was not found in the literature. Therefore, a value was chosen by referencing Gearhart's (1994) value for AChE inhibition. In this case it is 0.02 nmols-hr⁻¹. Once these two values are determined, the release rate can be calculated. The body

releases ACh as needed, not continuously, making it difficult to know when and when not to release the transmitter. According to Potter (1970), this release has been modeled at a constant rate, which is how it is used in the model.

Assumptions

Several simplifying assumptions are used in creating this PBPK model. One of those assumptions is that the different tissue concentrations everywhere are in an instant equilibrium state with the concentration of blood perfusing the tissue. A second assumption that simplifies the normally employed PBPK model is dealing with inhalation exposure. This creates an instantaneous equilibration of exposure concentration with blood flow in the pulmonary blood-gas exchange process (Shelley, 1995).

Methodology

Sensitivity Analysis

Several different parameter values were not found in the literature for specific organophosphates. These values have a direct impact on how AChE behaves. The parameters in question are; one, the different partition coefficients; two, the V_{max} and K_m values; three, the inhibition rate of AChE; four, the aging rate for the bond that takes place between the organophosphate and AChE; and five, the regeneration rate of AChE. Therefore, a sensitivity analysis was conducted in order to test a range of values for the different parameters.

In order to conduct this analysis, realistic values are required. Gearhart (1994) and Gentry (2002) recorded a set of values for each of the parameters needed. The

chemical these parameter values represent is parathion. Gentry documented the upper, lower, and mean limits for each value. These three values were used as a starting point to conduct the sensitivity analysis. By reducing the lower limits by a given value, additional parameter values were created. This was also done with the upper limit by adding a given value to create a total of nine sets of parameter values.

A combination of all these values was examined. This was accomplished by testing one value at a time, while holding all other values constant. Then all the values that are not being tested were changed to a new constant and then the tested parameter was run again with its different values (see Figure 9 for an example). This will be done with each parameter until completed. A list of all parameters can be found in appendices 5 and 6.

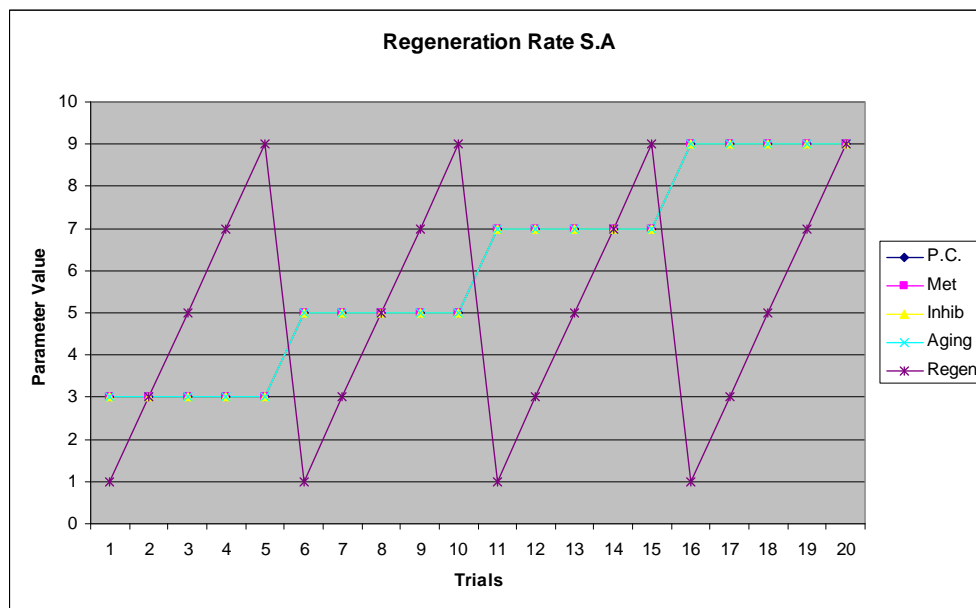

Figure 9. Graph of the different parameter values tested for the regeneration rate used in the sensitivity analysis.

The level of ACh in each tissue was tested for sensitivity to the parameter values mentioned above. The testing point is at a time of 60 minutes and the degree of change in ACh was examined to determine if the model is sensitive to the parameter in question. All values were graphed against each other and sensitivity was determined by the slope of the line. An example can be seen in Figure 10.

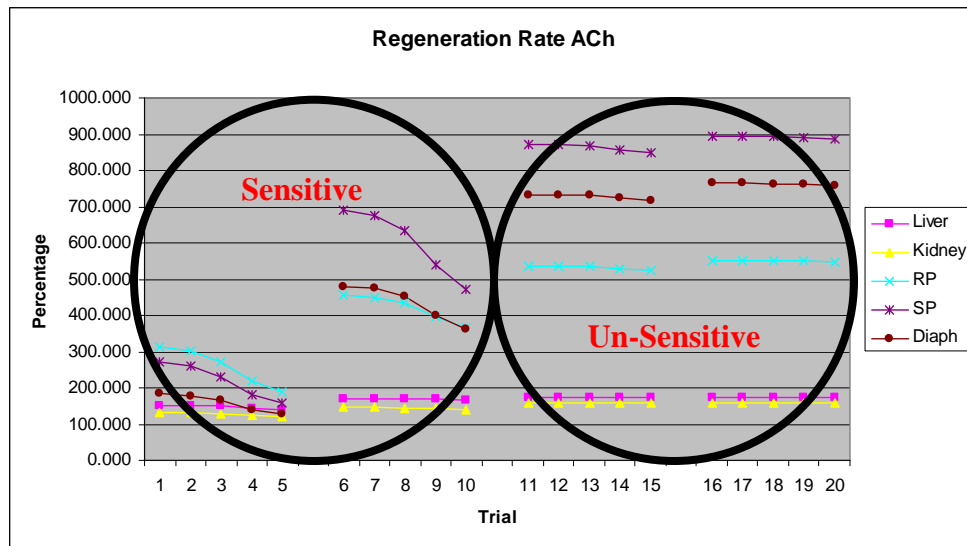

Figure 10. Example of a sensitivity report for the regeneration rate. Notice that the first ten trials show sensitivity while the next ten are relatively un-sensitive.

Sensitivity Analysis Results

Inhalation

The sensitivity analysis shows there are several areas where the model is sensitive to the parameter changes and in other areas where it is not. The output analyzed is the accumulation of ACh. Each of the five different parameters (or variables) was examined independently for inhalation, bronchial scrubbing and dermal effects. The sensitivity of the model to a particular parameter was done qualitatively. If one tissue demonstrates a

steady increase or decrease in slope, then it is considered sensitive. If all tissue groups have a slope that is approximately zero, then the model is not considered sensitive to the parameter.

Data points were taken from each model output to compile a behavior of the overall levels of ACh in each tissue group. After every simulation, the point on the graph at time 60 minutes was recorded for the level of ACh in each tissue. These points were then plotted against each other on a trial (simulation) vs. percentage graph. This provides a nice visual output of any changes that occur in the different tissues at this point in time.

The results for the inhalation portion are as follows (the complete results can be seen in appendix 7):

- *Partition Coefficients:* All twenty trials were deemed to be sensitive, but at varying degrees.
- *Metabolism:* The model was not sensitive to these parameters across any of the trials. Therefore, a set of values will be chosen for these parameters and they will not be changed throughout the testing.
- *Inhibition Coefficient:* All twenty trials were deemed to be sensitive, but at varying degrees.
- *Aging Rate:* Only trials one through five were deemed not sensitive. Six through twenty were considered to be sensitive to the changes in values and therefore, the parameter combinations for trials six through twenty will be used in the testing portion.
- *Regeneration Rate:* Half of the trials for this parameter were considered sensitive (trials one through ten). The model was deemed not sensitive to trials eleven through twenty and therefore, these parameter combinations will not be used in the testing portion.

There are eight separate partition coefficients – one for each of the different tissue groups (i.e. brain, liver, kidney, richly perfused tissues, slowly perfused tissues, diaphragm, bronchial tissue, and the skin). The partition coefficients are treated as a single unit and all of the possible combinations are not used in the sensitivity analysis due

to the sheer number of simulations that would have to be run and examined. Therefore, when the value of the partition coefficients is changed, all values change in the same direction (positive or negative) and by a pre-described amount. Likewise, the Michaelis-Menten metabolic parameters for each tissue group are examined in the same manner.

Bronchial Scrubbing

This portion is only to determine if the model is sensitive to the bronchial scrubbing coefficient. This parameter is tested by setting all the other parameters (partition coefficients, Michaelis-Menten values, inhibition coefficient, aging rate, and regeneration rate) at a fixed value and then changing the scrubbing coefficient (Figure 11). If the model is considered sensitive to the bronchial scrubbing coefficient, then it is assumed that all combinations of the other parameters are sensitive as well. This then requires additional testing with different combinations of the partition coefficients, the Michaelis-Menten values, the inhibition coefficient, the aging rate, and the regeneration rate.

The bronchial scrubbing coefficient partitions the absorbed agent between alveolar blood-gas exchange and bronchial wall absorption. The results demonstrate that the model is not sensitive to bronchial scrubbing, mainly because all of the tissues have minimal change in ACh levels. Additional testing, with different parameter combinations and exposures, will be conducted to determine whether or not these results are exclusive to the parameter values used in the sensitivity analysis. Complete results can be seen in appendix 7.

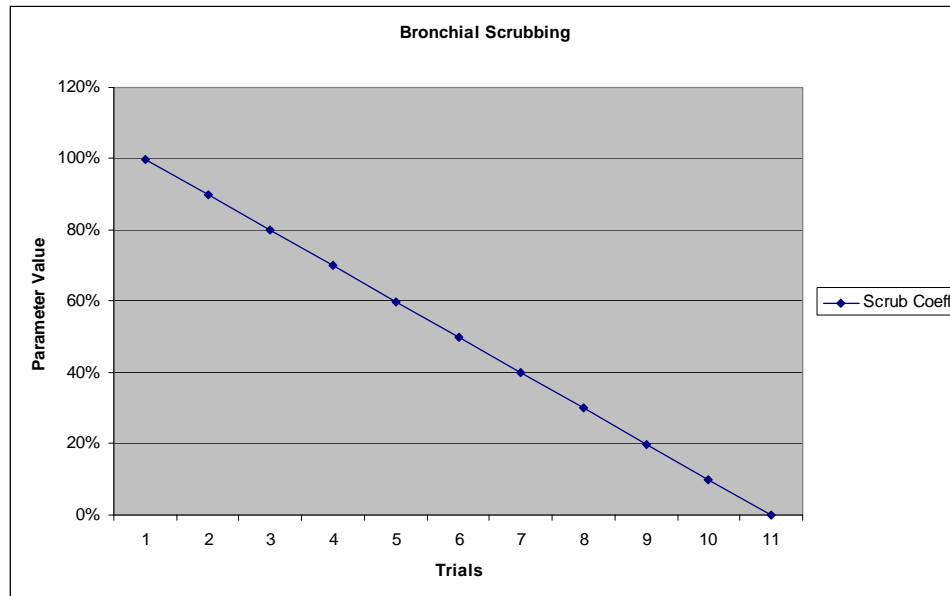

Figure 11. The different values of the bronchial scrubbing coefficient that were used in the sensitivity analysis.

Dermal Exposure

As was done in the bronchial section, this portion of the sensitivity analysis was to determine if the model was sensitive to the transfer coefficient and the skin surface area exposed. Therefore, the partition coefficients, the Michaelis-Menten values, the inhibition coefficient, the aging rate, and the regeneration rate are set to a given value and the transfer coefficient and skin surface area are changed using different combinations of the two. Again, if any combination of the transfer coefficient and the skin surface area are deemed sensitive, then all combinations will be considered sensitive and additional testing with more combinations of the other parameters will be completed.

After graphing the results of the model, it shows that about two-thirds of the trials are sensitive to the parameter changes. Trials one through forty-four show large changes in the levels of ACh. After trial forty-four, there is really no change in the levels of ACh.

The results for the levels of ACh can be seen in Figure 12 and the remaining results can be found in appendix 7.

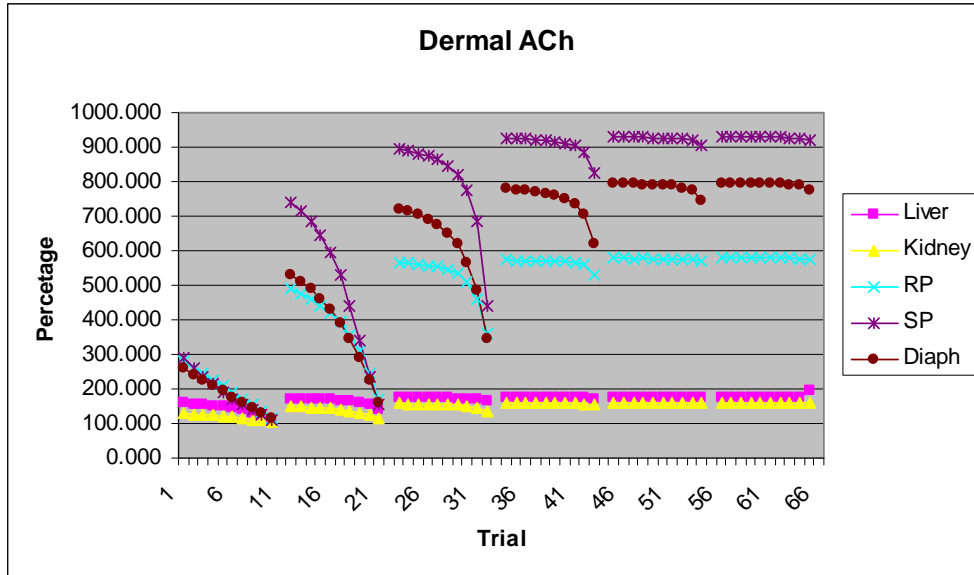

Figure 12. Results of the sensitivity report for dermal exposure. Notice that the model becomes less and less sensitive after the forty-fourth trial.

Testing Portion

The sensitivity analysis is used to develop the parameter values for testing the model under exposure conditions. The trials tested will be completed in the same manner as the sensitivity analysis. For example, when examining the partition coefficients, the inhibition coefficient, the aging rate, and the regeneration rate will be set at value one (see appendix 5 for actual values) and the partition coefficient will start at its value one and will gradually be increased. Once all the partition coefficient values are run through the model, the inhibition coefficient, aging rate, and regeneration rate will be increased. The partition coefficient will be reset to its number one value and increased again until all values are completed. This is repeated until all predetermined combinations are run through the model. After the partition coefficients are tested, the same procedure will

follow with the inhibition coefficient, the aging rate, and the regeneration rate for all predetermined combinations (see appendix 8 for a list of all combinations).

There are three different parts that will be accomplished in testing the model. The inhalation portion, which looks at an inhalation exposure only; a section on bronchial scrubbing, which adds an element of scrubbing a particular amount of the organophosphate from the air as it is being inhaled; and a dermal section which will examine the effects of an organophosphate exposed to the skin. Each section will be tested following the pattern above. All three sections are set up slightly different than each other. For the inhalation and bronchial scrubbing trials, each set of combinations will also be tested against three exposures. The first being 0.00117 milligrams per liter of air, the second 0.00058 milligrams per liter of air, and the third is 0.00003 milligrams per liter of air. The first dermal exposure is 0.37062107 milligrams, the second exposure is 0.1840554 milligrams, and the third exposure is 0.00954734 milligrams. These are different than the others because of their route of entry. In order to be able to compare the dermal effects with the inhalation effects, the exposures need to be normalized. This is accomplished by determining what the total amount of organophosphate is absorbed in the body via inhalation. Then testing different dermal exposures until one is found that absorbs the same amount of organophosphate into the body. This process is completed for the three inhalation exposures.

The inhalation portion of the testing will serve as the baseline to be compared to the bronchial scrubbing and dermal exposures. The bronchial scrubbing has an additional parameter than the inhalation tests. This parameter is called the scrubbing coefficient,

which determines the amount of organophosphate that will be “scrubbed” out of the airflow. From the sensitivity analysis, two scrubbing coefficients will be used in the testing portion (see appendices 5 and 6 for list of values). Each combination for the partition coefficients, the inhalation coefficient, the aging rate, and the regeneration rate will be tested against each of the two scrubbing coefficients and exposure levels (Figure 13).

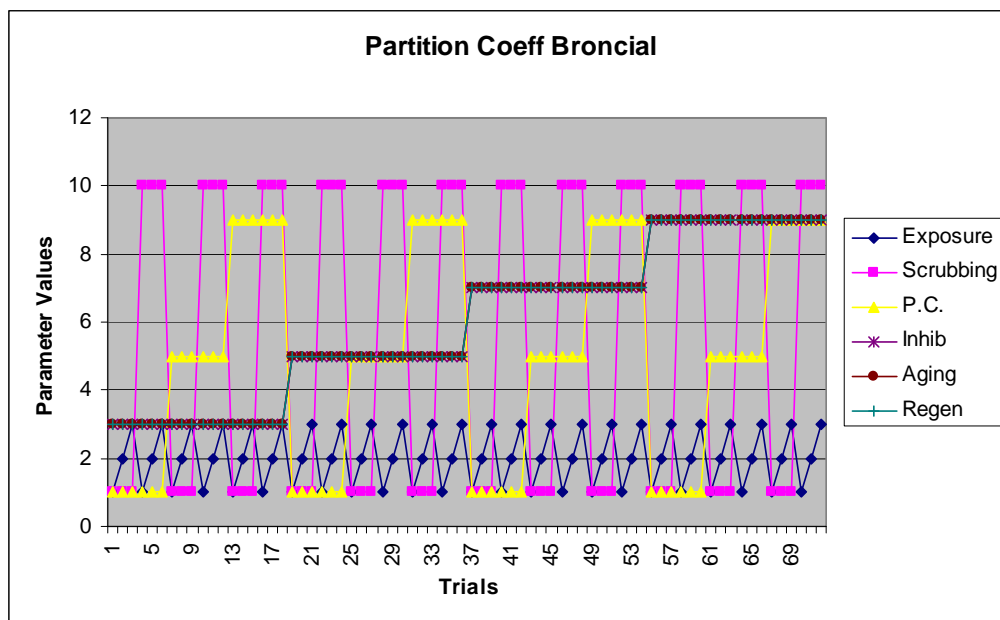

Figure 13. Set of bronchial exposure trials to be tested for the parameter “partition coefficient” in the model.

The dermal portion of the model has two additional parameters than the inhalation portion. These parameters are the transfer coefficient and the skin surface area. The transfer coefficient determines how much of the organophosphate will actually penetrate the skin and the skin surface area defines the amount of skin actually exposed to the organophosphate. The combinations for the partition coefficients, the inhalation coefficient, the aging rate, and the regeneration rate will run against different

combinations of the transfer coefficient and skin surface area (Figure 14). Unlike the inhalation and bronchial scrubbing portions of the model, the parameter being tested (i.e. partition coefficients, inhalation coefficient, aging rate, or regeneration rate) is not increased. Here the mid-point (value 5) is used and it is not increased as it is in the inhalation and bronchial sections. This was to reduce the amount of simulations to run from the massive increase of parameter combinations from the addition of the two parameters.

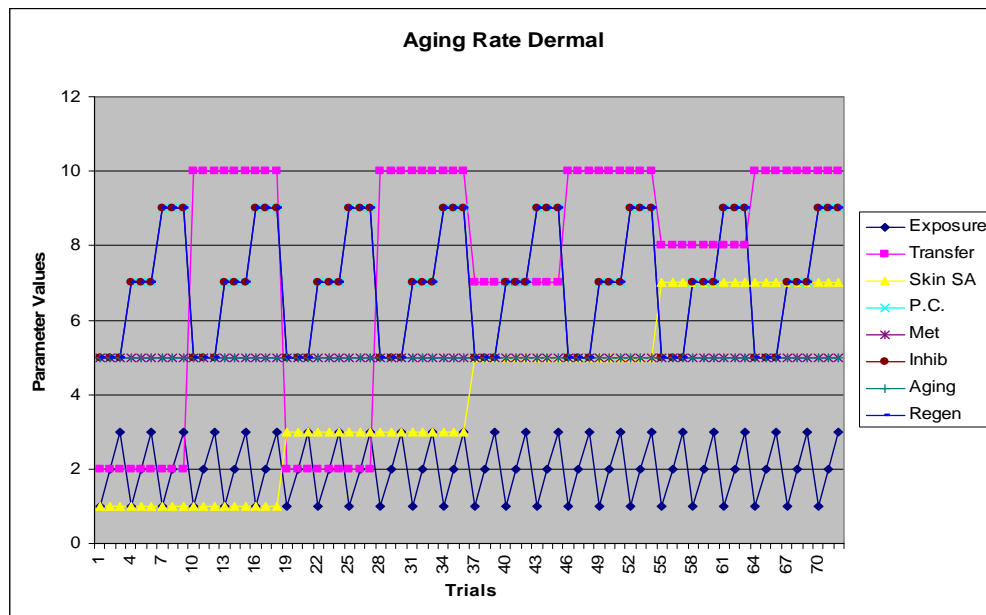

Figure 14. Set of dermal exposure trials to be tested for the parameter “aging rate” in the model.

IV. Analysis and Results

Analysis and results

An organophosphate has chemical specific values for the partition coefficients, the inhibition coefficients, the aging rate, and the regeneration rate. Therefore, each of the 100 plus combinations inserted into the model represents a different organophosphate. The organophosphates are not specifically named because determining the actual partition coefficients, inhibition coefficients, aging rate, and regeneration rate is a difficult process. In order to measure these different parameters, in vivo testing must be accomplished. For this particular model each combination represents a generic organophosphate with parameter values determined from a set found in the literature.

The parameter values for parathion were used as a starting point. Nine different values were developed for each parameter in each tissue (numbered 1 through 9), all of which can be referenced in appendix 5. Gentry (2002) recorded both the upper and lower limits for each of the tissue groups as well as the mean value. These represented three of the values for the model (values 4, 5, and 6). The other values (1 through 3 and 7 through 9) were determined by expanding beyond the limits of the upper and lower bounds. Each tissue's lower bound value was subtracted by a number to obtain a new value (number three); the number was then subtracted again to obtain an additional value (number two). The process was repeated a third time to obtain the last value (number one). The same process was done with the upper limit; a number was added to each parameter to obtain new value seven, then eight, then nine. The different parameter combinations in the model produced a wide range of ACh levels in the different tissues with an exposure of

0.00117 milligrams per liter of air. This suggests that each trial run shows different toxicities as well as symptoms that are experienced throughout the body. The varying levels of ACh can be seen with exposures of 0.00058 milligrams per liter of air and 0.00003 milligrams per liter of air as well. The three exposures used for both the inhalation tests as well as the bronchial scrubbing tests are 0.00117 milligrams per liter of air (exposure 1), 0.00058 milligrams per liter of air (exposure 2), and 0.00003 milligrams per liter of air (exposure 3).

The mass balance for the organophosphate is important to maintain throughout the experimentation process. A correct mass balance helps to create a more realistic model and help translate that to what is actually going on inside the body. This particular model's mass balance was off by approximately seven percent. A possible reason for this is in the construction of the blood compartments. Due to software limitations they had to be constructed differently than the other tissue compartments. As a result, the organophosphate that enters the body does not equal the organophosphate distributed throughout the body. This percentage is small enough not to have any adverse effects on the general model output.

The inhalation tests are used as the baseline for the rest of the experiments. This provides a basis to compare the bronchial scrubbing and dermal sections of the model. Once an inhalation trial is run at exposure 1, the level of ACh buildup for each tissue is recorded at time 60 minutes and placed on a graph (trial number vs. percentage). This is repeated for trial two, three, etc. Once all trials for exposure 1 were completed, they were run a second time with exposure 2 and again at exposure 3. The baseline results are

shown in Figure 15. The trends between the three exposures do not change. Each tissue increases or decreases respectively in each exposure. The level of ACh attained is the only change. As a result, only exposure 1 will be discussed unless stated otherwise. The full results are displayed in appendix 9.

Inhalation

In examining the results, one parameter is evaluated at a time (i.e. partition coefficients, the inhibition coefficient, the aging rate, and the regeneration rate). This helps to compare what the different combinations of parameters are doing under the same exposure scenario. In comparing the different parameters, there was a variation of trends noticed throughout the trials. When the partition coefficient was examined, there were definite changes in ACh levels. As the partition coefficients are increased there is an increase in the ACh levels in the brain, liver, kidney, slowly perfused tissue, and the diaphragm. Even though the levels of ACh in the liver and kidney increase, they increase at minimal levels when compared to the other tissues. When examining the structure of the model, these results stem from the concentrations of ACh in the different tissues. After exposure the concentrations of ACh in the liver and kidney tissue change very little when compared to the other tissues. Since the concentration of ACh does not vary with different parameter values, the change in the rate of hydrolyzaiton will be minimized, therefore, causing minimal increases in the level of ACh in the liver and kidney as parameter values change. Whereas, the other tissue groups have a higher change in ACh concentration with the different parameter values after exposure and therefore, their

hydrolysis rate changes more drastically producing higher levels of ACh than in the liver or kidney.

The richly perfused tissue tends to decrease as the partition coefficients are increased (Figure 15a). This tends to occur because of the amount of BuChE is present in the richly perfused tissue. As the partition coefficient is increased, it decreases the rate in which organophosphate leaves the tissue via venous blood. This in turn gives the organophosphate additional time to bind with the BuChE in the tissue. The richly perfused tissues have more of this enzyme than the other tissues. Therefore, more organophosphate is lost due to BuChE than in any of the other tissue. This binding between the organophosphate and the BuChE provides less organophosphate to bind with AChE which results in lower levels of ACh in the richly perfused tissues.

A second observation is when the inhibition coefficient, aging rate and the regeneration rate are increased; the level of ACh is higher in the tissue with the same partition coefficients. This follows the concept that as the inhibition coefficient is increased, the less hydrolyzing AChE can perform, which in turn causes ACh to increase. With the higher aging rate, AChE is permanently bound with the organophosphate at a higher rate, providing a smaller “pool” of inhibited AChE for the body to regenerate back into free AChE. Therefore, the body can not produce and regenerate enough AChE to compensate for the amount of AChE that is being inhibited and aged. This causes the levels of ACh to increase in the tissue even though the partition coefficients stay the same. A sample of the different ACh levels in the different tissues at an exposure of 0.00117 milligrams per liter of air for 60 minutes is shown in Table 4.

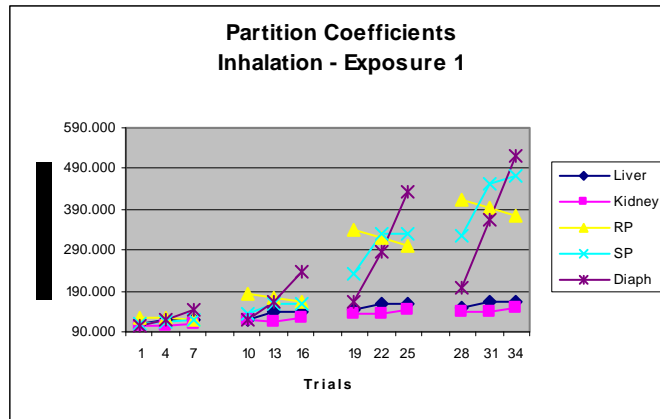

a) Exposure 1

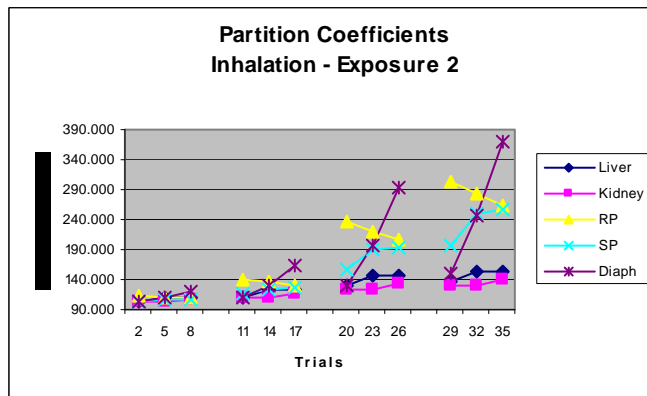

b) Exposure 2

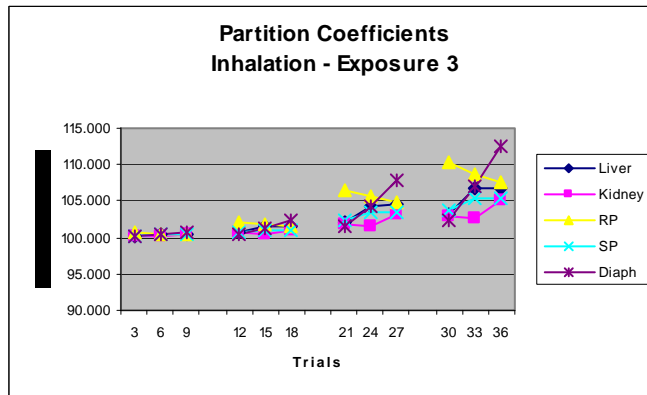

c) Exposure 3

Figure 15. This shows the level of ACh (in percentage) in different tissues from a variety of organophosphates. The trends are the same for each exposure. The difference is the change in ACh levels. The levels of ACh are lower when exposures 2 and 3 are used. Note: trial 1 in (a) has the same parameter values as trial 2 in (b) and trial 3 in (c). The only difference is the exposure concentration.

Table 4. Examples of ACh Levels in Different Tissues

Exposure 1	Tested Parameter							
	Partition Coeff		Inhibition Coeff		Aging Rate		Regeneration Rate	
	1	34	7	34	7	25	10	16
Trials								
Brian	269.5	4617.3	2966.7	4617.3	4250.2	4611.8	4239.2	2743.4
Liver	107.8	164.2	137.0	164.2	140.4	164.1	140.7	130.9
Kidney	106.7	149.0	120.7	149.0	117.0	149.0	117.3	111.4
Richly Perfused	125.7	375.2	209.2	374.2	183.1	375.2	184.8	148.3
Slowly Perfused	110.3	470.7	159.6	468.8	163.3	470.7	164.8	135.8
Diaphragm	106.0	522.4	137.6	521.5	170.6	522.4	171.9	139.2

This is a sample of the trials run at exposure 1 (0.00117 mg/l) after 60 minutes has transpired. The numerical values show the increase in ACh, from a baseline of 100%, for the different tissues in a given trial. The tested parameter and trial number represents which combination of parameters being run through the model. For example: trial 1 under the partition coefficient parameter shows the brain having 269.5% of ACh above normal. Trial 1 represents each of the parameter values (partition coefficients, the inhibition coefficient, the aging rate, and the regeneration rate) at their lowest values. Trial 7 represents the inhibition coefficient at its highest value, while the partition coefficients, the aging rate, and the regeneration rate are at their lowest values. A complete list of the combinations can be seen in appendix 8.

The inhibition coefficients had different trends from the partition coefficients.

The richly perfused tissue, slowly perfused tissue, and the diaphragm each increase exponentially, although at different rates (Figure 16a). The brain (Figure 16b and c) and the diaphragm have the same trend types as they did when examining the partition coefficients. A major difference between the partition coefficients and the inhibition coefficient is when the partition coefficients, aging rate, and the regeneration rate are increased; the levels of ACh in the liver, kidney, richly perfused, and slowly perfused tissues remain fairly constant. This tends to suggest that the inhibition coefficient is not dependent on the partition coefficients, aging rate and the regeneration rate. Upon further examination of the model, there is evidence to why this is the case. In order for aging or regeneration of AChE to occur, it must be inhibited first. Therefore, the amount of AChE inhibited will determine how much AChE can be regenerated back into free AChE or

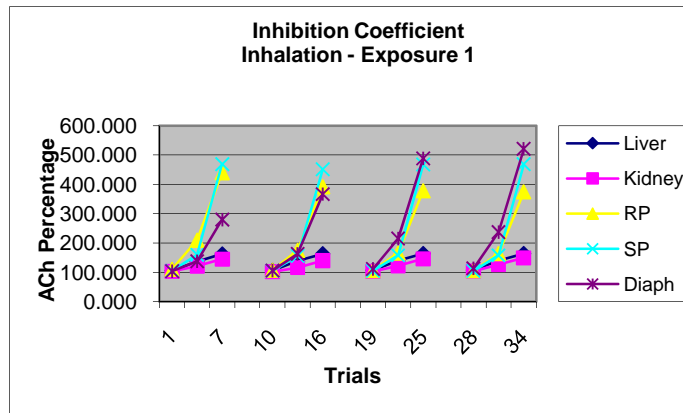

a)

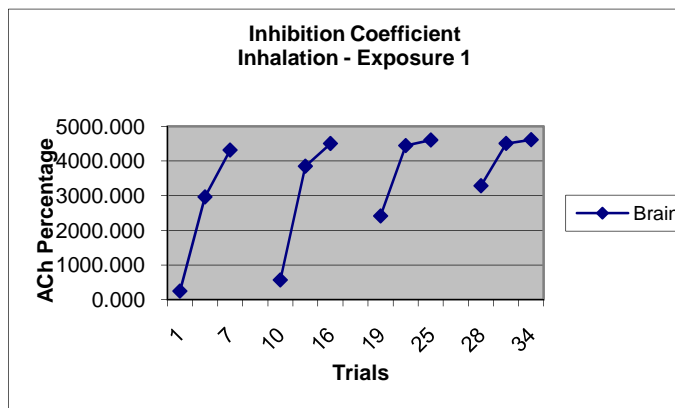

b)

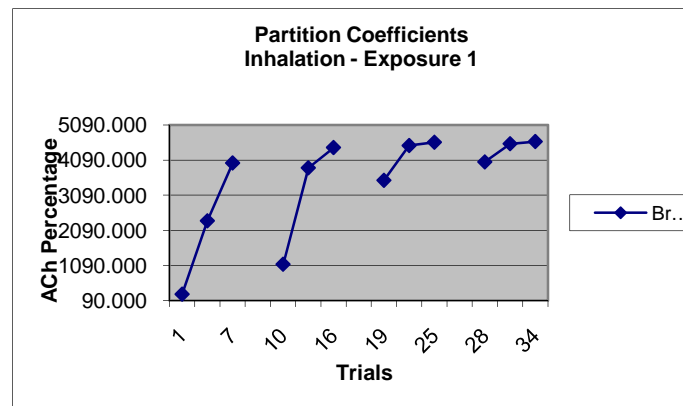

c)

Figure 16. This shows the levels of ACh in different tissues when examining the different inhibition coefficients (a and b). Figure 16c displays the level of ACh present when examining different partition coefficients (used to compare with Figure 16b).

aged into a permanent bond. The partition coefficients are not directly tied to the inhibition coefficient and perform their own computations separately allowing the inhibition coefficient to perform on its own.

A combination of both the inhibition and partition coefficient trials trends are seen in the aging rate combinations. Each tissue saw an increase in ACh levels as the aging rate increased. This is reasonable because, when the aging rate is increased, the time for the bond between AChE and the organophosphate to become permanent is reduced. Therefore, AChE is being lost faster, reducing the amount available to hydrolyze ACh, causing ACh levels to rise. There was also an increase in ACh levels when the partition coefficients, the inhibition coefficient, and the regeneration rate were increased. When these parameters are at their lower values (i.e. trials 1, 4, and 7 in Figure 17a) the trends of the different tissues have a very small slope, but when higher values (i.e. trials 19, 22, and 25 in Figure 17a) of the partition coefficients, the inhibition coefficient, and the regeneration rate are used it typically looks like the inhibition coefficient trials. The brain increases as well, but as the partition coefficients, inhibition coefficient, and the regeneration rate are increased, the increase in ACh is not as prevalent (Figure 17b). Upon further examination, the brain never goes above 4600%, regardless of the parameter combination. This may indicate that the brain is approaching its maximum value. Therefore, as the partition coefficients, inhibition coefficient, and the regeneration rate are increased, the increase is smaller because it is reaching its new steady-state value.

The regeneration rate's trends were opposite of all the others. Unlike the previous trials, the combinations that were run for this portion showed a decrease in the liver,

kidney, slowly perfused tissue, richly perfused tissue, diaphragm, and the brain. As the regeneration rate was increased, it produced less and less of an ACh buildup in the tissues. When the partition coefficients, inhibition coefficient, and the aging rate were increased, the drop in ACh levels is greater (Figure 18). This is reasonable because if there is a high regeneration rate, this allows the bound AChE to be freed into unbound AChE and allows the ACh to be hydrolyzed, bringing the levels down.



a)

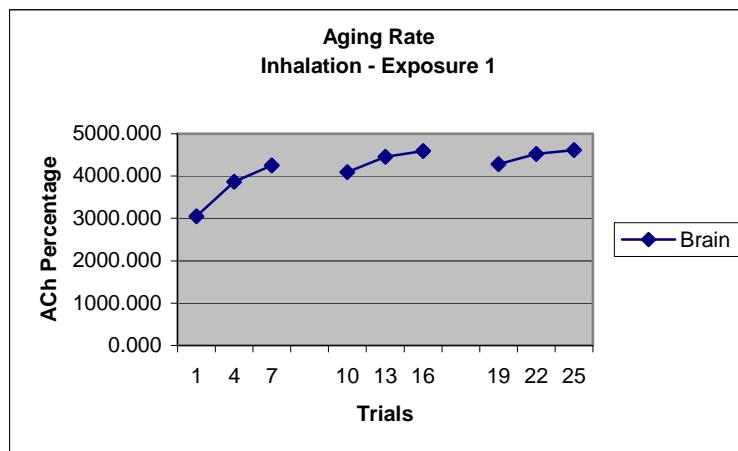

b)

Figure 17. Displays the level of ACh present in different tissues with varying aging rates.

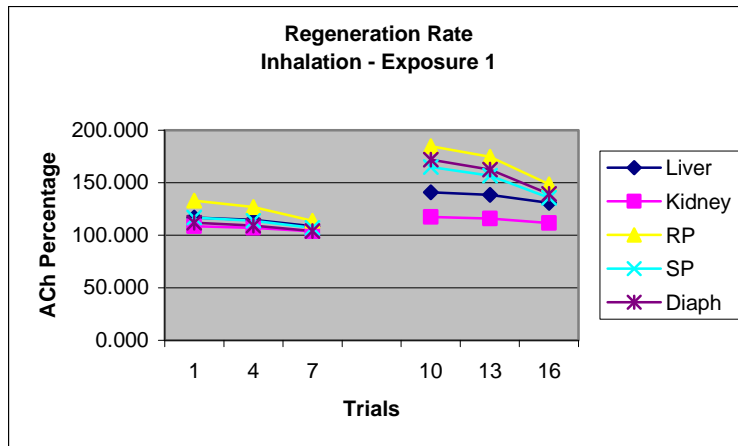

a)

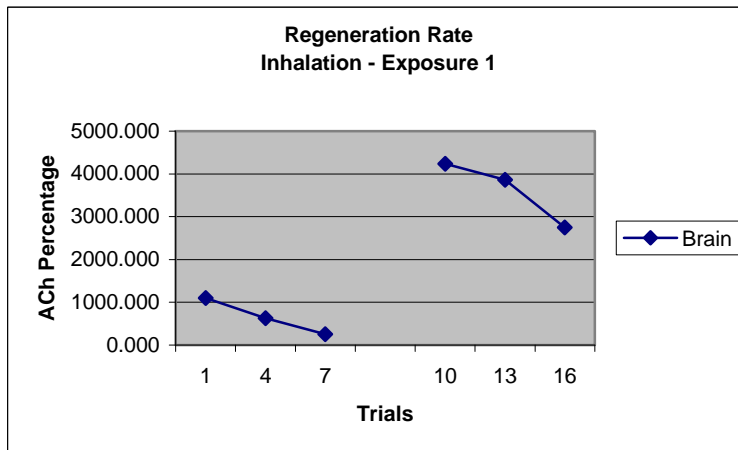

b)

Figure 18. Displays the level of ACh present in different tissues with varying regeneration rates.

Bronchial Scrubbing

Bronchial scrubbing was examined next. To simplify the comparison process, only two of the scrubbing coefficients will be discussed, 1 and 10 (this represents 100% and 10% respectively of the organophosphate being scrubbed from the bronchial or conductive zone of the lungs). For a complete list of data see appendices 5 and 8. As was done in the inhalation section, only exposure 1 will be discussed. This is because the trends for exposures 2 and 3 are the same as exposure 1, the only difference being the

actual level the ACh reached during each trial. Additionally, only the partition coefficients will be examined.

The output suggests that bronchial scrubbing does not have an effect on how the body reacts to organophosphates. It was thought that there would be a slight delay in how fast the levels of ACh in the different tissues would reach those seen in the inhalation (baseline) tests. This was not the case. There was scarcely a change in the amount of ACh buildup in any of the tissues. This was consistent when using high or low scrubbing coefficients. Both of the bronchial scrubbing coefficients used have a minimal change in the level of ACh that is present in each tissue group. Figure 19 displays the lack of change between the inhalation tests with both sets of scrubbing coefficients used. This suggests that the amount of organophosphate that is scrubbed from the airways enters the bloodstream fast enough to cause no effect on the rate at which the levels of ACh will reach at a given time.

After looking deeper into the model structure, the exact amount of organophosphate is present at any given time when inhalation occurs. The difference is where the organophosphate is located. Depending on the scrubbing coefficient, the organophosphate is either in the arterial blood as it passes through the blood-gas exchange or it is in the bronchial tissues being partitioned into the venous blood. In either case the model transfers the organophosphate immediately into the arterial blood from the venous blood, minimizing any difference in levels of ACh in any tissue whether bronchial scrubbing takes place or not. These results confirm the sensitivity analysis in that the model was found not to be sensitive to changes in the scrubbing coefficient.

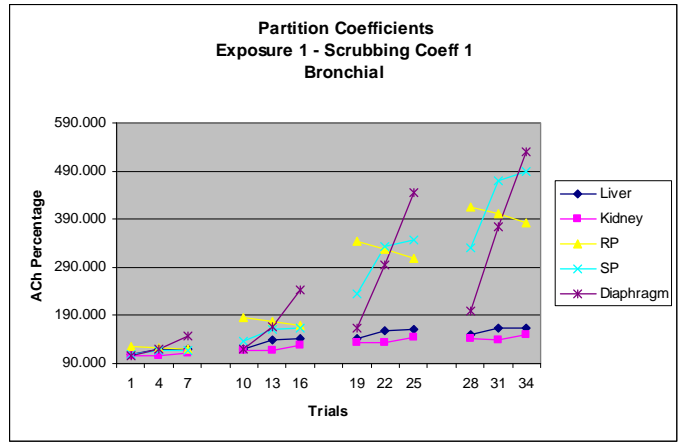

a)

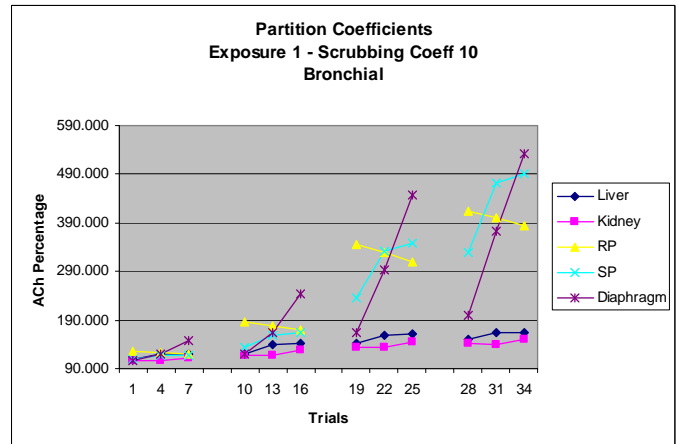

b)

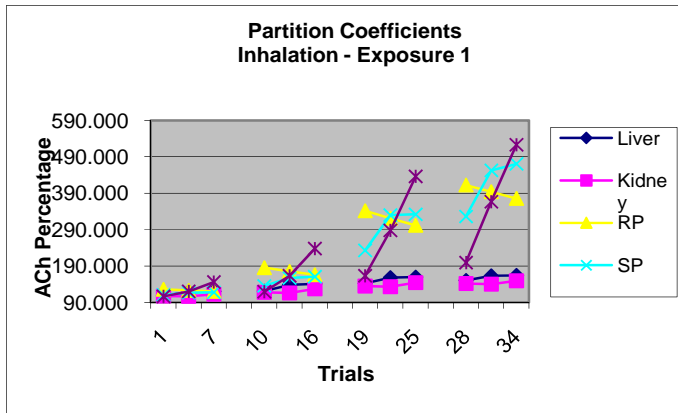

c)

Figure 19. Displays the rate of change between scrubbing coefficients 1 (Figure a) and 10 (Figure b). The trends do not change much between the higher (Figure a) and lower (Figure b) scrubbing coefficient. Figure c displays the baseline inhalation ACh levels in the tissues for comparison. Note: there is not any change in the levels of ACh in any of the three figures.

Dermal

Finally, the effects of a dermal exposure were tested. Unlike the inhalation or bronchial scrubbing portions, different exposures are required to make a proper comparison. Instead of an exposure measured in concentration, which is used in the inhalation and bronchial scrubbing portions of the test, an exposure measured in mass is used for the dermal testing. This rationale is developed by reviewing the material safety data sheet, such as sarin, which states that the LD₅₀ is measured in milligrams (Federation of American Scientists, 2006). The dermal exposures are developed from the three inhalation exposures. The amount of organophosphate absorbed into the body is calculated and then varying masses of an organophosphate are entered into the model until the amount absorbed equals that of the inhalation exposure. The three dermal exposures used are: 0.37062107 milligrams (exposure 1), 0.1840554 milligrams (exposure 2), and 0.00954734 milligrams (exposure 3).

The dermal tests have two additional parameters than those in the inhalation exposure. These parameters are the skin transfer coefficient and the skin surface area. The skin transfer coefficient determines how much of the organophosphate actually enters the body through the skin medium and the skin surface area designates how much of the skins surface is exposed to the organophosphate. When examining the different combinations for the partition coefficients, the results showed an increase in ACh levels in the liver, kidney, richly perfused tissue, slowly perfused tissue and diaphragm when the inhibition coefficient, aging rate, and regeneration rate are increased. Figure 20 shows these levels for all three exposures. This trend remains constant regardless of

which transfer coefficient or skin surface area is used. These trends are also the same when examining the outputs for the aging rate and the regeneration rate (full results are located in appendix 9).

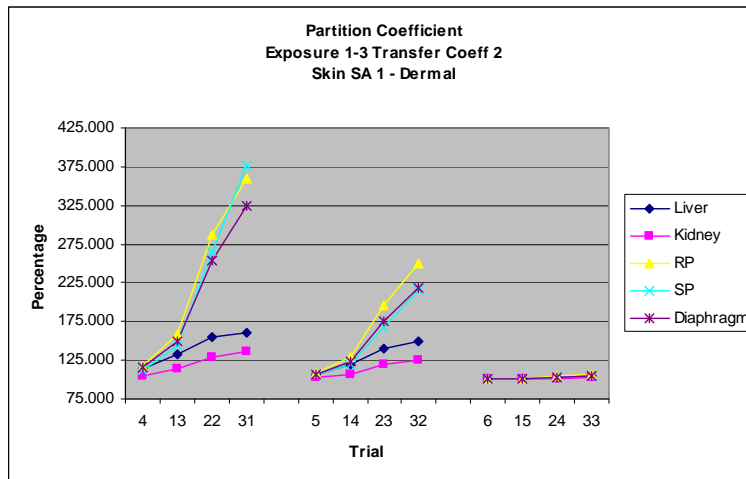
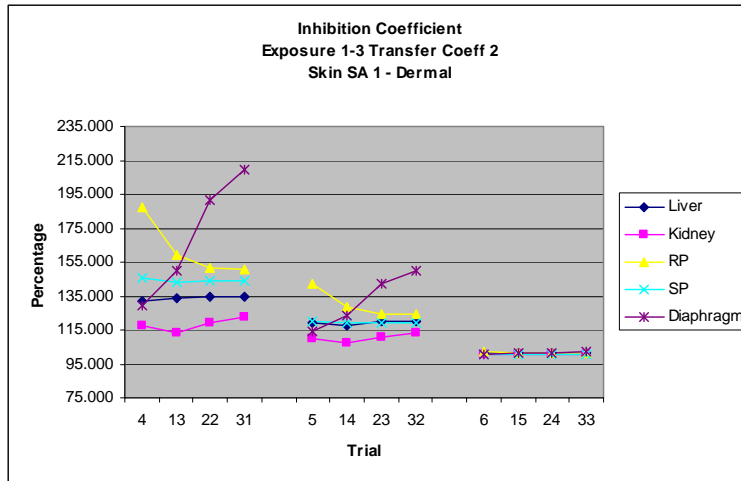
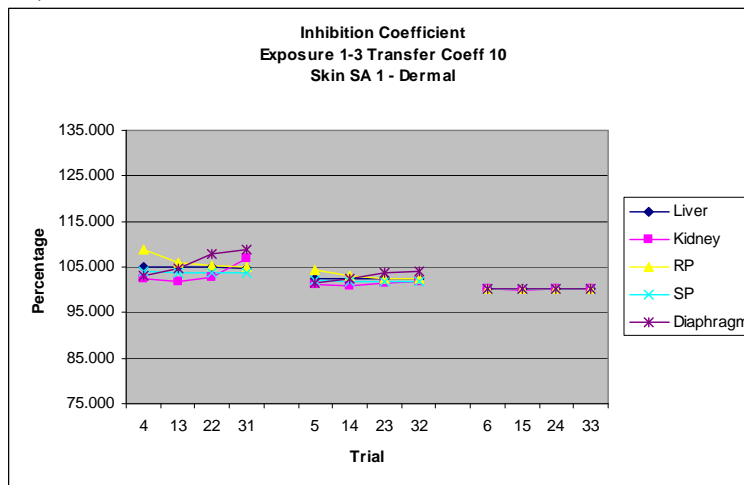

Figure 20. Trials 4, 13, 22, 31 display the rates of change at exposure 1, whereas, trials 5, 14, 23, 32 display the ACh levels at exposure 2, and trials 6, 15, 24, 33 display ACh levels when exposure 3 is modeled. All trials are exposures to the skin.

The outputs of the model for the inhibition coefficient provide a different trend than that of the partition coefficients, aging rate, and the regeneration rate. Figure 21a and b show that the liver, kidney, and the slowly perfused tissues do not increase nor decrease very much. This reinforces the earlier statement that the inhibition coefficient is not dependant on the partition coefficients, aging rate, and the regeneration rate. The diaphragm and the richly perfused tissues are the only two that display any change in ACh levels. When compared to the baseline (inhalation), these are the only tissues that have changes in ACh levels.



a)



b)

Figure 21. Displays almost zero slopes for the change in ACh levels in each tissue after the transfer coefficient is changed (except for the diaphragm and the richly perfused tissue). The difference between Figure a and Figure b is the level of ACh in the tissue reaches after exposure.

Evidence from the results suggests that when a small amount of skin (low surface area) is exposed and the organophosphate has a high rate of transfer through the skin, the buildup of ACh in the different tissues is lower than that of inhalation. This is implied by the amount of time it takes for the organophosphate to fully enter the blood stream and circulate throughout the body will take longer than inhaling the agent (USAMRICD,

2000). This presents the possibility that the levels of ACh in the tissues do not reach the same levels as an inhalation exposure. Exploring a high skin exposure (high surface area) and low transfer rate produce higher levels of ACh in the body tissues than the baseline did. Upon further study of the model, these results appear to be the product of the exposure normalization process. The normalization was conducted with a skin surface area of 1 cm². The new exposure was used for all skin surface areas tested. It appears the exposure should be normalized for each skin surface area used in the model.

Examining a small exposure to the skin and a low transfer rate (low transfer coefficient and low skin surface area) produce different results than the first two scenarios described above. The levels of ACh in the tissues are lower than those demonstrated by the higher transfer coefficient. This suggests that the time it takes to achieve inhalation levels of ACh in the tissues is longer, if reached at all. At 60 minutes, the outputs do not demonstrate whether or not the levels of ACh will actually reach the inhalation levels. When the time of exposure is increased, the levels of ACh do eventually reach (and exceed) the levels attained with inhalation (Figure 22).

This delay can be contributed to the concentrations of organophosphate in the tissue after the exposure takes place. The volume of the skin is much larger than the volume of the bronchial tissue. The larger volume of the skin produces a lower concentration of organophosphate in the tissue, which in turn takes longer for it to “diffuse” into the blood and therefore slows the rise in ACh levels throughout the different tissues.

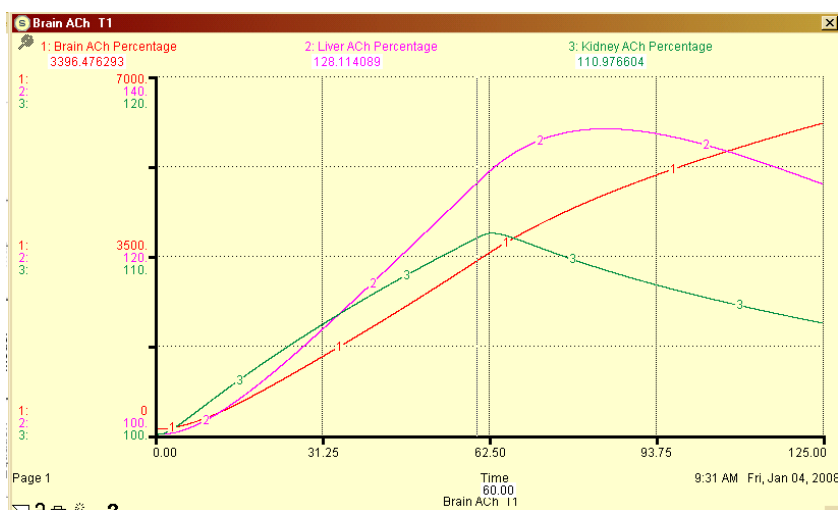

a)

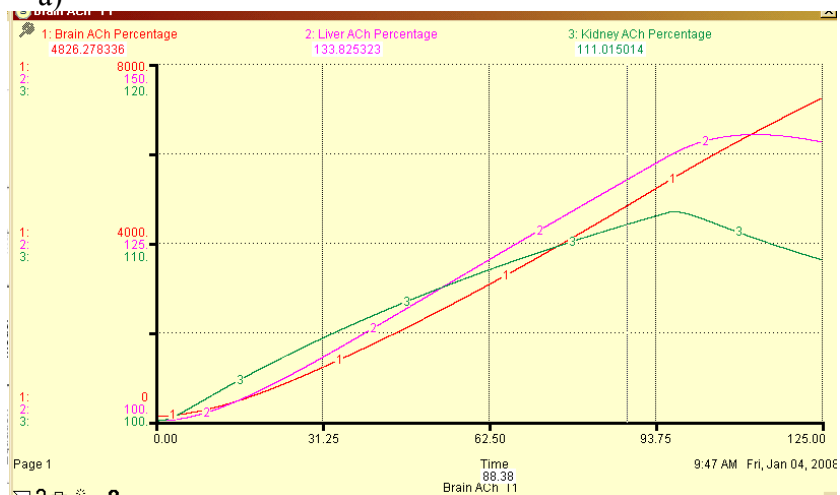

b)

Figure 22. Figure a demonstrates the building up of ACh in three tissue groups from an inhalation exposure. The levels of ACh are measured at 60 minutes. Figure b shows the same tissues when the body is exposed to a dermal exposure. As can be seen it takes 88 minutes of exposure for all of the tissues to at least equal the inhalation exposure.

A piece of the model that required further addressing was the molecular weight of each organophosphate. The model uses the molecular weight to convert milligrams of organophosphate to nmols to show how much AChE, CaE, and BuChE is bound. The results of all three testing areas (inhalation, bronchial scrubbing, and dermal) were

determined using a single molecular weight. Fourteen different organophosphates were chosen (see Table 5) to be used to test this portion of the model. Each molecular weight was assigned to a different combination of parameter values. Parathion was used as a starting point.

Table 5. List of organophosphates used in model

	Organophosphate	Molecular Weight
1	Sarin	140.1
2	Tabun	162.0
3	Soman	182.2
4	Ethoprop	242.4
5	Trichlorfon	275.4
6	Fenthion	278.3
7	Propetamphos	281.3
8	Parathion	291.3
9	Phosmet	317.3
10	Malathion	330.4
11	Tribenuron Methyl	395.4
12	Dioxathion	456.5

To match the different molecular weights with a combination of parameter values, two chemicals were examined. These chemicals were diazinon and trichloroethylene. The pesticide diazinon has higher partition coefficients than parathion and it also has a higher molecular weight (diazinon 304.4 g/mol) than parathion (291.3g/mol) (Poet, 2004). Trichloroethylene, which has lower values for its partition coefficients in the different tissue groups also has a lower molecular weight than parathion (131.4 g/mol to 291.3 g/mol) (Covington, 2004). Using these similarities, if an organophosphate had a higher molecular weight than parathion then it was assigned to a set of parameters that

were higher than those used for parathion. This was also done if the molecular weight was lower.

The results displayed different values in what the build up of ACh was in each of the tissue groups. The ACh levels were both higher and lower than the results provided from using only one value. There was no difference in the trends when comparing the results from using multiple molecular weights with the results from using one molecular weight (Figure 23). The difference is seen in the magnitude of ACh in the tissues. The trials that were run with different molecular weights tend to have lower levels than the trials that were run where all combinations of parameter values have the same molecular weight.

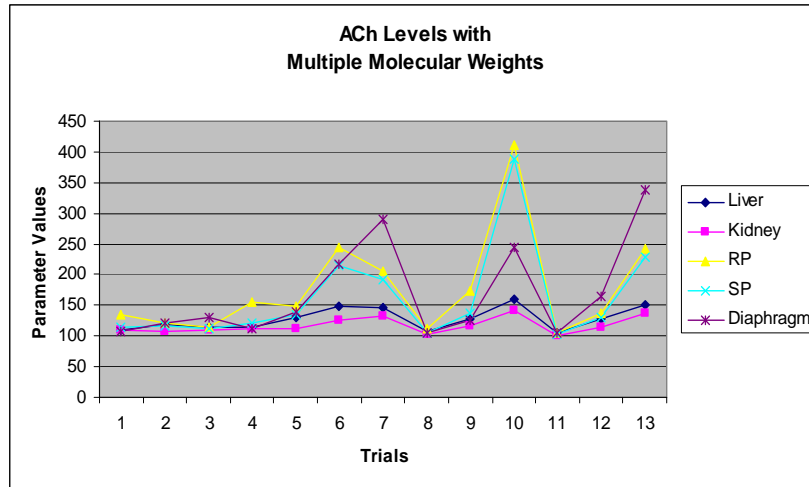

a)

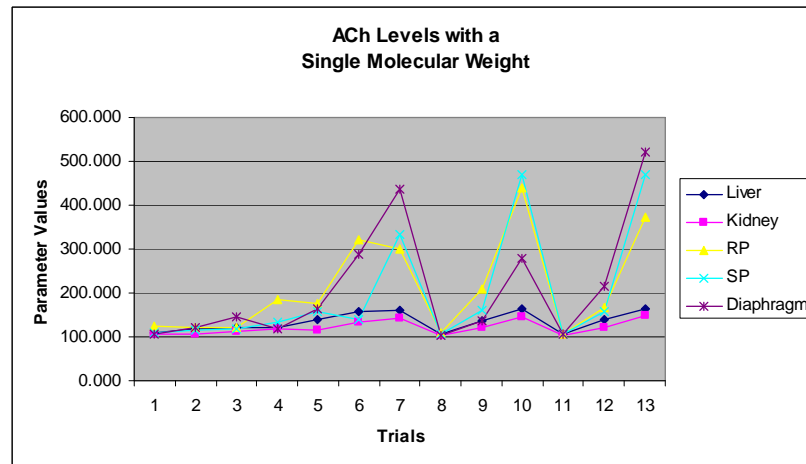

b)

Figure 23. Figure a displays the levels of ACh in five different tissue groups when a different molecular weight is used for each trial that was ran. Each trial also has a different set of parameter combinations (partition coefficients, inhibition coefficient, aging rate, and regeneration rate). Figure b displays the levels of ACh when one molecular weight is used for all trials. It can be seen that the trends are the same, only the magnitude is different.

V. Conclusions

Conclusions

With the ease to obtain and produce organophosphates, it appears future attacks using these agents as a weapon is only a case of when it will happen. Being educated on what the agents can do as well as how the body reacts to them can have life saving results. Organophosphates with slight differences in the parameter values can have very different results in how high the levels of ACh will reach in the various tissues. For example; when the partition coefficients were left unchanged and the inhibition coefficient, the aging rate, and the regeneration rate were raised slightly (inhalation tests, exposure 1, comparing trial 1 with trial 10), the level of ACh in the brain rose from 270% to 1122% respectively.

The model also suggested that the relationship between the exposure and the level of ACh in the tissue is not linear. By examining exposures 1 and 2, which is a 50% decrease in concentration (0.00117 mg/l to 0.00058 mg/l), the buildup of ACh in the tissues decreased less than half. This is seen in the ACh levels of the brain (26% decrease), the liver (12% decrease), and the kidney (6% decrease) after having a 50% decrease in exposure level. This is also seen when comparing exposures 2 and 3 (0.00058 mg/l and 0.00003 mg/l). The exposure drops approximately 1,833%, but the tissues range from 1,833% (close to linear) to 8% decrease in ACh levels. These different levels suggest that if an individual receives twice the dosage, that person will not necessarily receive symptoms twice as bad.

The bronchial scrubbing tests results were compared with the inhalation results, and one conclusion was determined. The bronchial scrubbing action that takes place does not have an effect on the ACh levels in different tissues. When examining the organophosphate parathion, the lack of differences in ACh levels can be seen. For example, the brain has an ACh increase of 3,914% after an inhalation exposure of 0.00117 mg/l (exposure 1). Using a low scrubbing coefficient, this number is still 3,914% and with a high scrubbing coefficient it can drop to as low as 3,909%. This suggests that bronchial scrubbing does not have an effect on the intake of organophosphates into the body.

The dermal exposure tests also produced lower levels of ACh than the inhalation exposures under the same conditions. This tends to support the information found in USAMRICD (2000) that symptoms from a dermal exposure can take longer to materialize than from an inhalation exposure. This too can be seen by looking at the results for parathion, as stated before the inhalation exposure for the brain produced an increase in ACh of 3,868%. When testing a dermal exposure equivalent to the inhalation exposure the ACh level dropped between 3,668% (with a high transfer coefficient) and 455% (with a low transfer coefficient). Meggs' (2003) paper provides an example of an individual being exposed to an insecticide for 15 minutes and the next day became permanently paralyzed in certain areas of his body. With the lower levels of ACh, again, more time is available to don personal protective equipment or perform decontamination procedures with dermal exposure.

It should be noted that the data shown in this study are based on endpoint analysis and does not go into examining the dynamic buildup of ACh from the time it enters the body.

Future Work

A time of 60 minutes was used throughout this study. Different time increments can be examined to see how much change will occur, if any, in the ACh levels. Other areas of work to investigate are specific organophosphates as information on parameter values become available. This will allow one to identify how much buildup of ACh occurs and how that corresponds to the type of symptoms one would experience for specific organophosphates. Future work for a dermal exposure can determine how long it would take for an exposure to equal an inhalation exposure for different organophosphates (i.e. produce the same amount of ACh buildup in tissue). Studying what dermal exposures will produce the same effects as an inhalation exposure for a fixed amount of time. This is demonstrated by looking at the results of an inhalation exposure and recording the ACh levels. The same dose was administered for a dermal exposure (normalized from the inhalation exposure) and using a transfer coefficient of 0.8, it took approximately 88 minutes (28 minutes longer) for the dermal levels to reach the same (or above) levels as the inhalation. By experimenting with this with different organophosphates, a “lag” time in the ACh levels can be determined to understand the type of symptoms to expect when encountering a dermal exposure over an inhalation exposure.

Organophosphates are dangerous chemicals, every one of them from insecticides to nerve agents. Being overexposed to any of them can have disastrous results. This study looked at many different agents in a very general perspective. A main observation was that the higher the values for the partition coefficients, the inhibition coefficient, the aging rate, and the lower the regeneration rate appeared to produce more toxic effects than lower values. This would suggest that organophosphates with the higher parameter values are the worst agents (one that produces the highest levels of ACh in the body) and have the most adverse effect on the body by producing the severest symptoms.

Appendix 1 Model

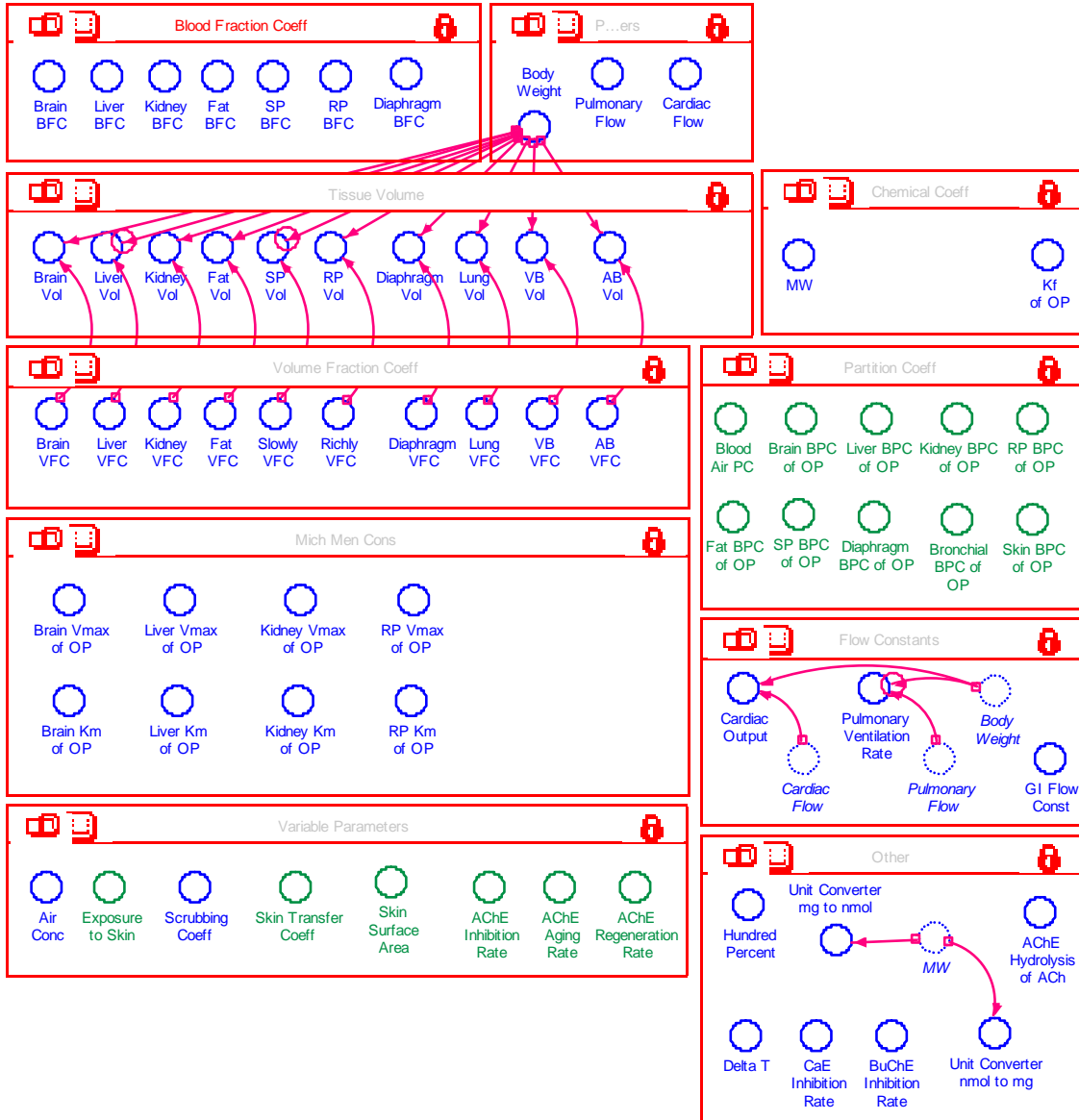

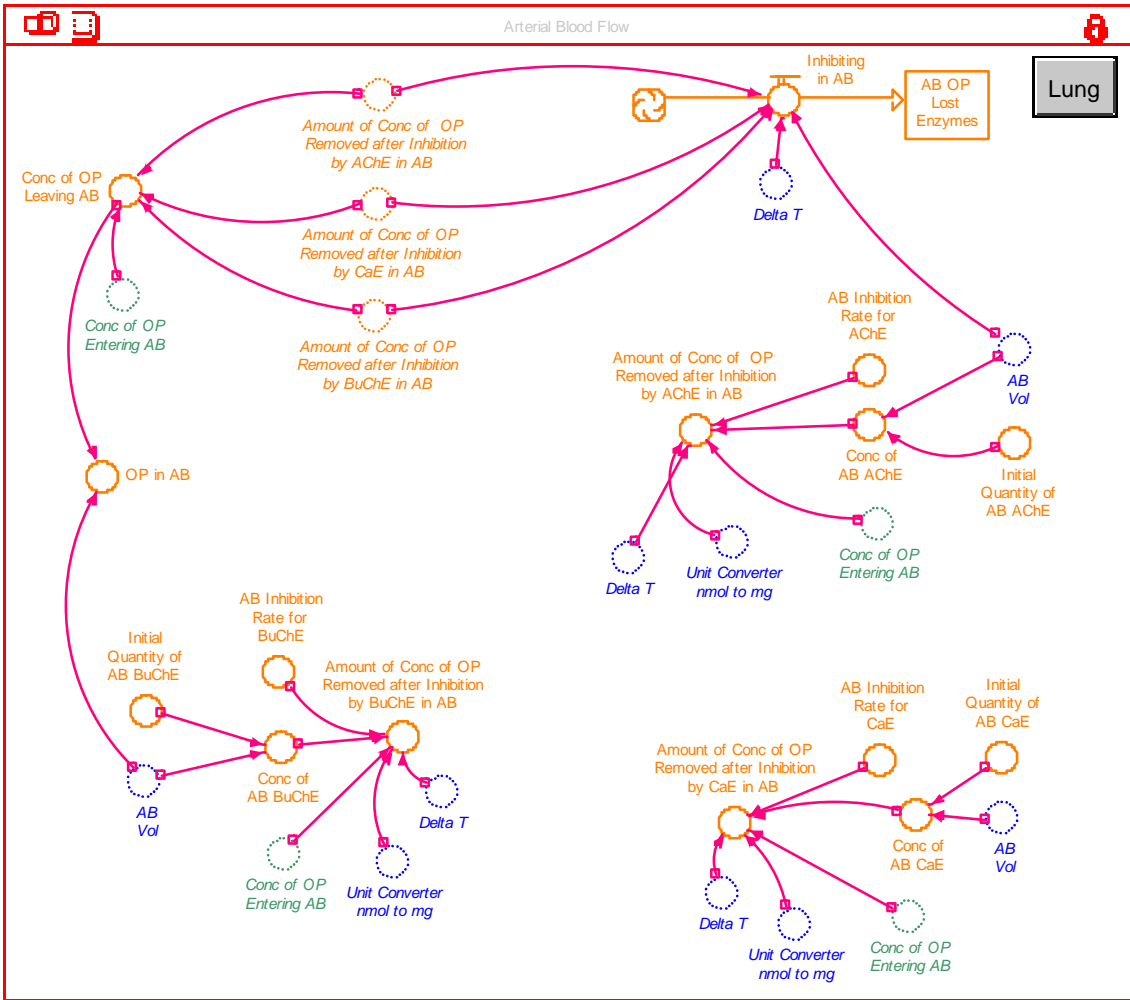
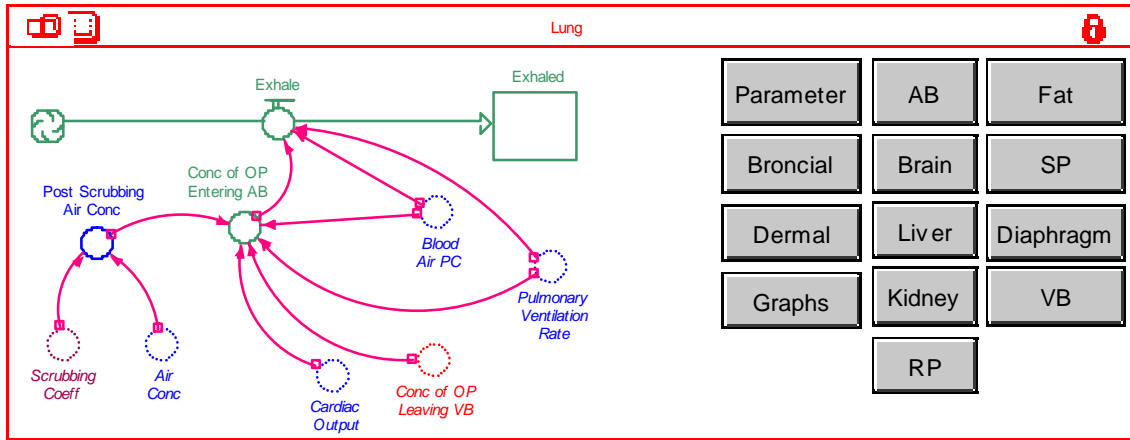

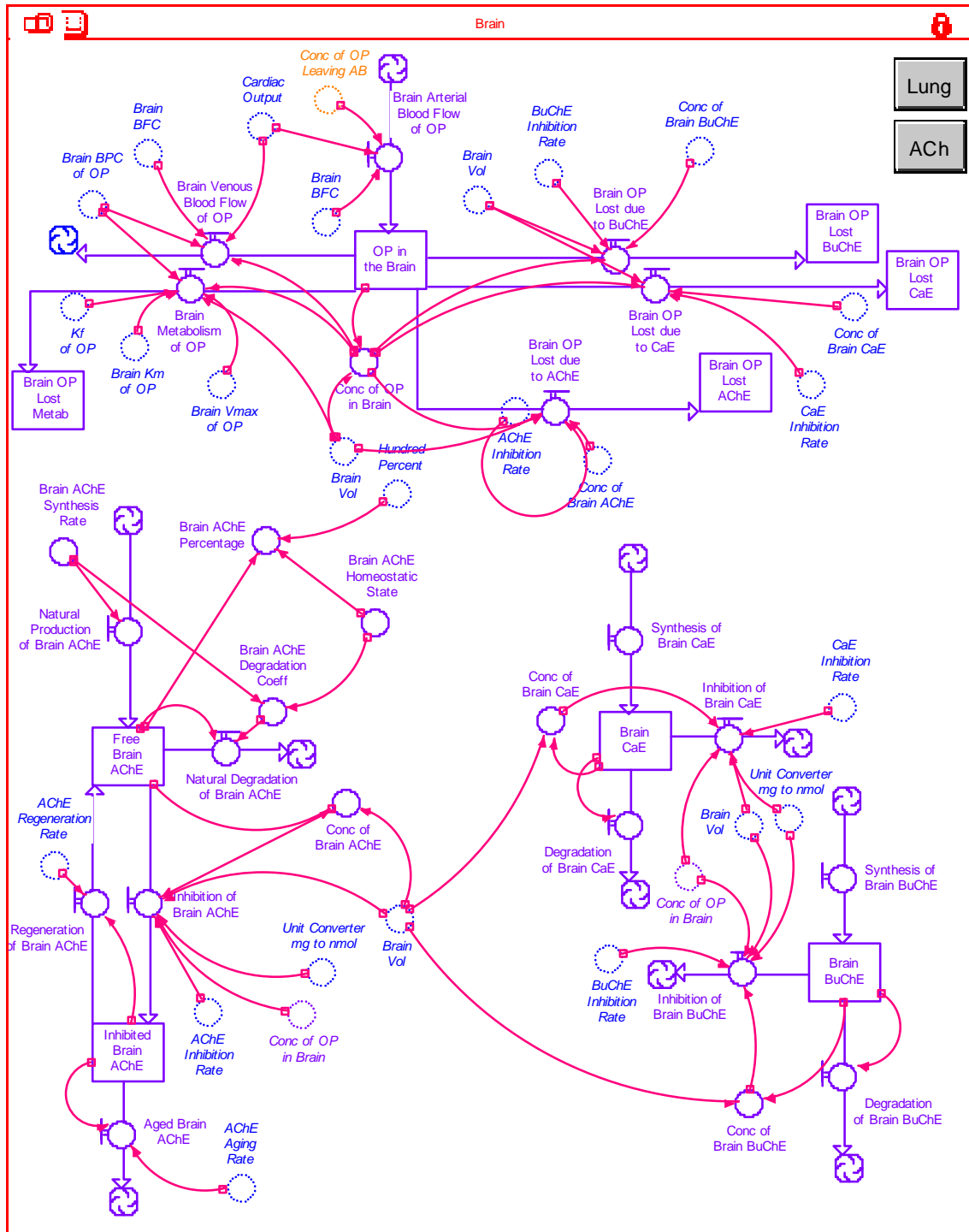

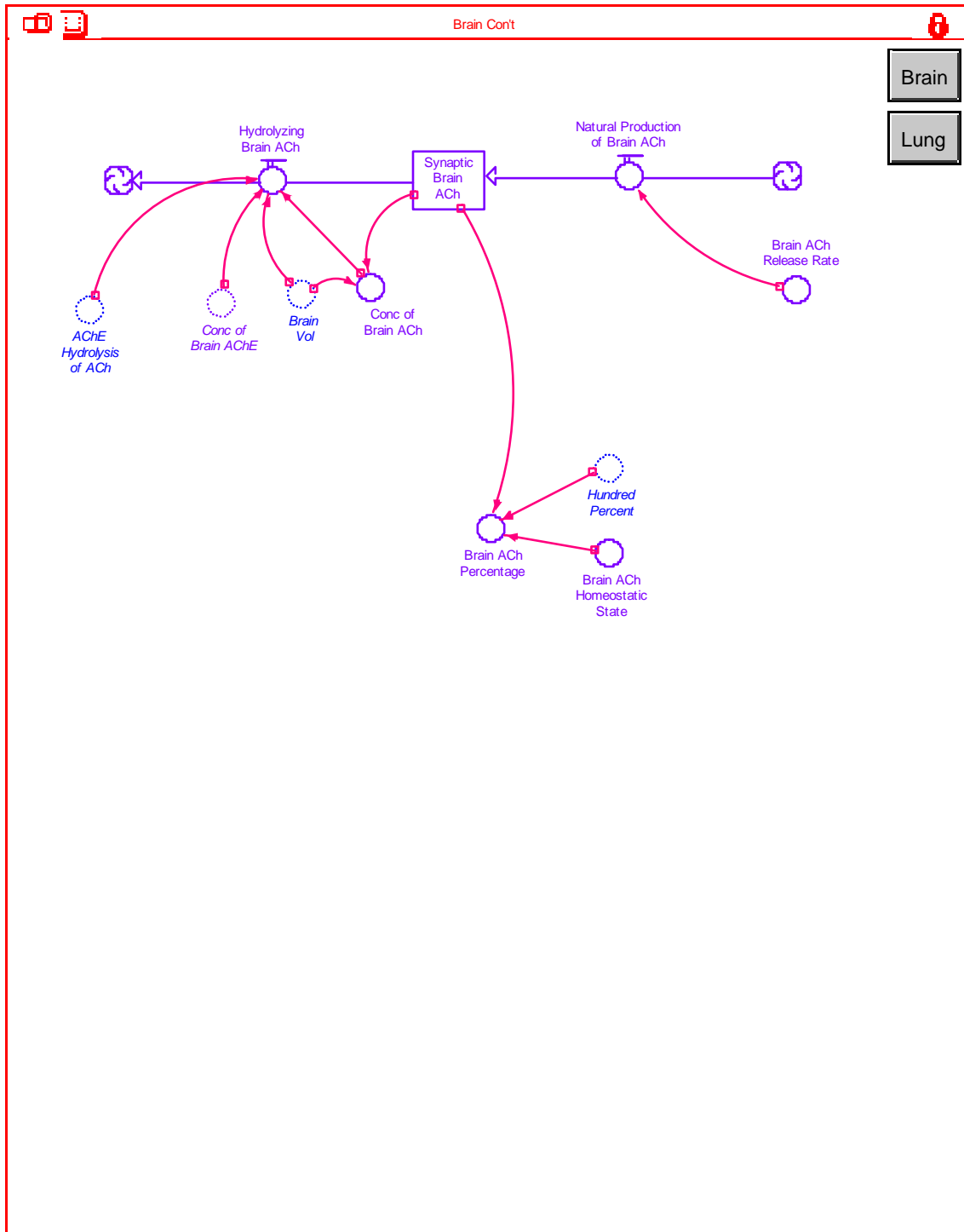

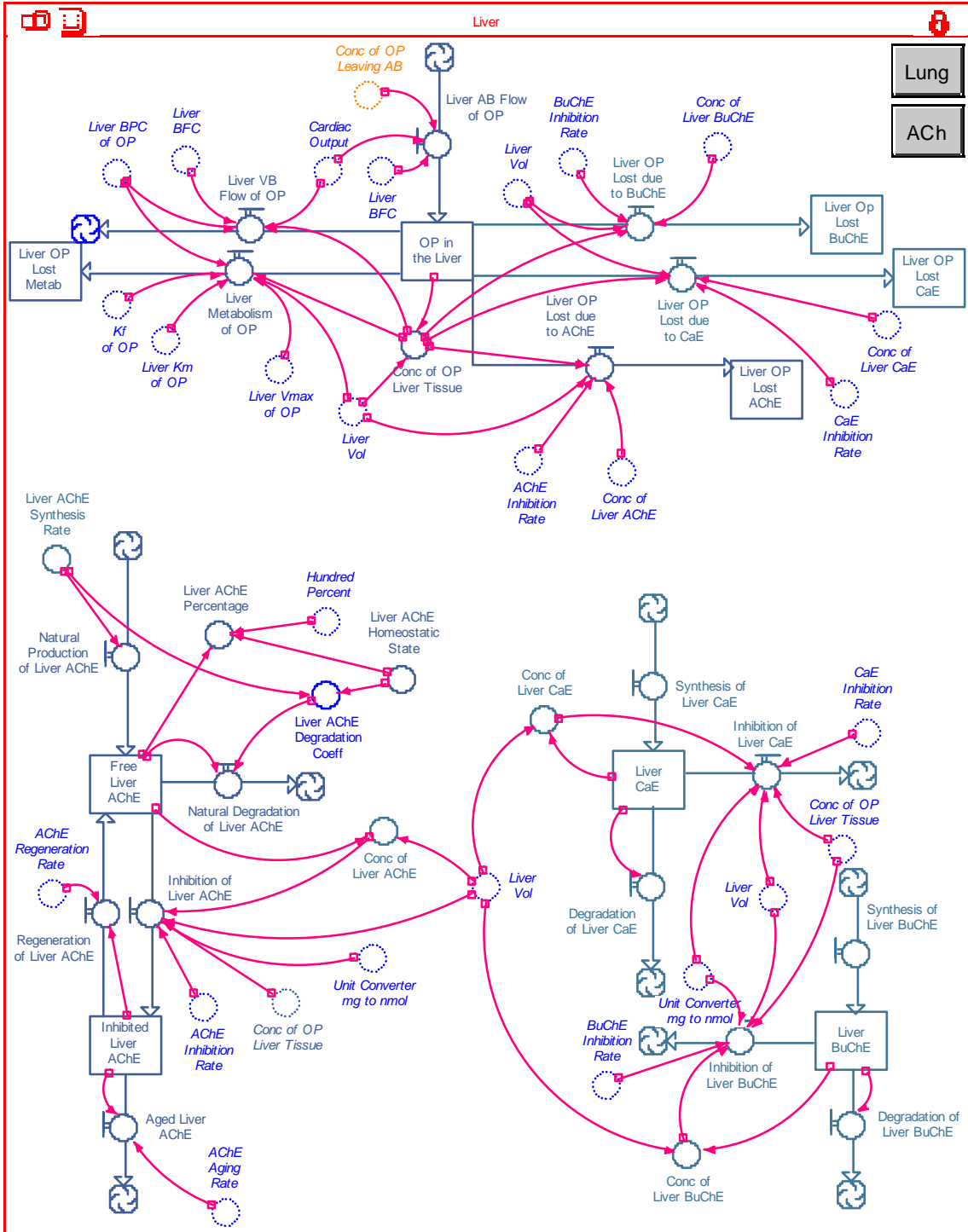

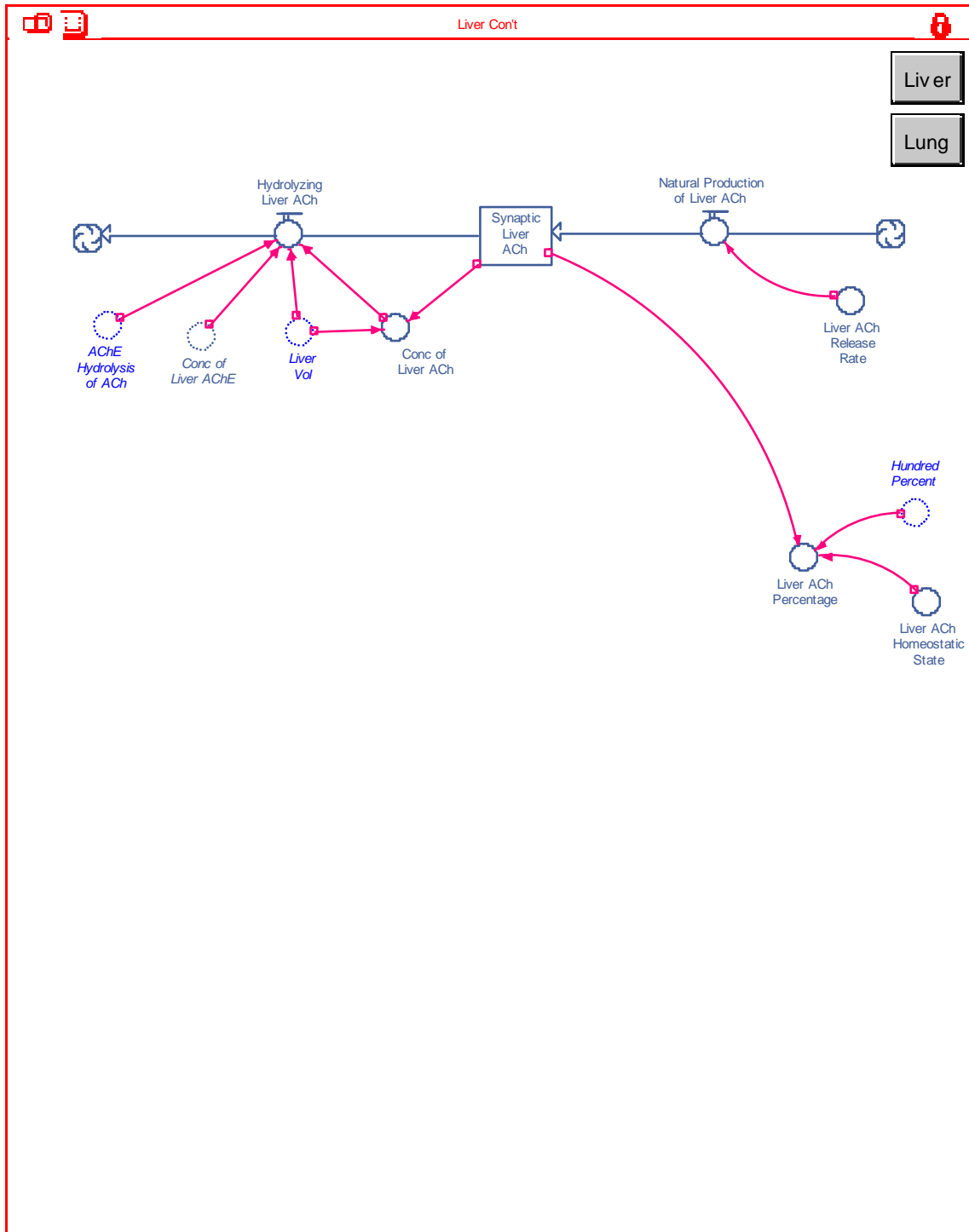

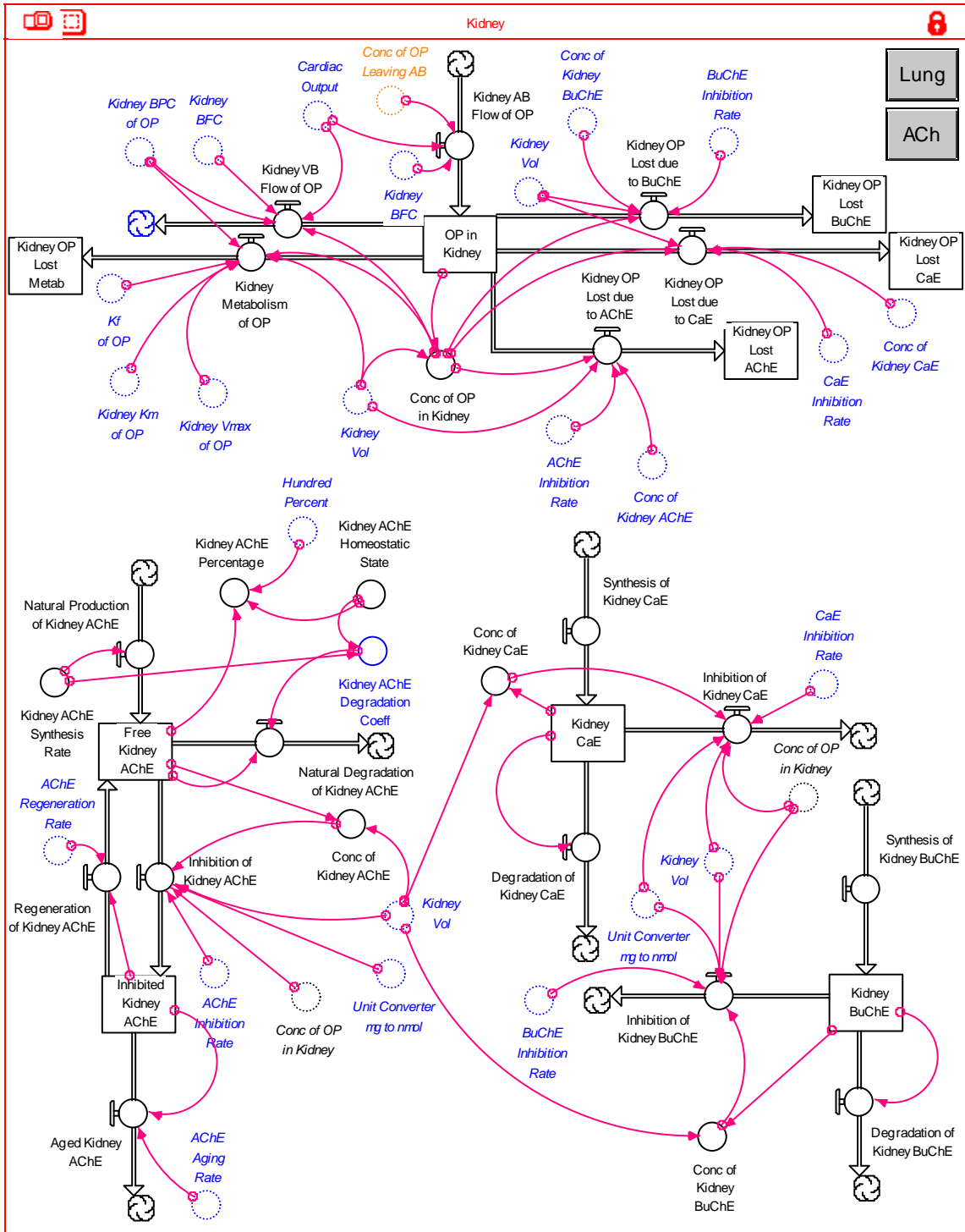

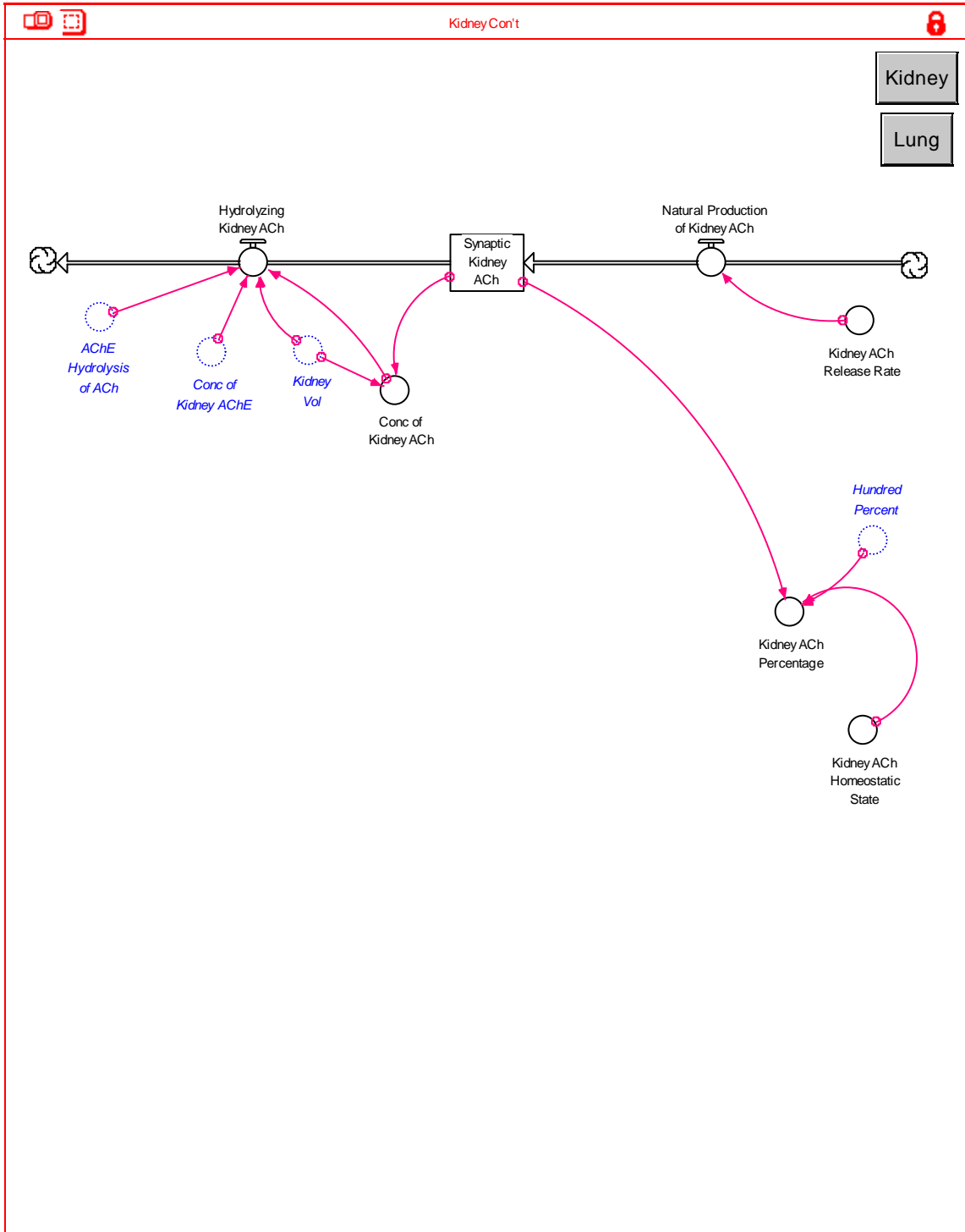

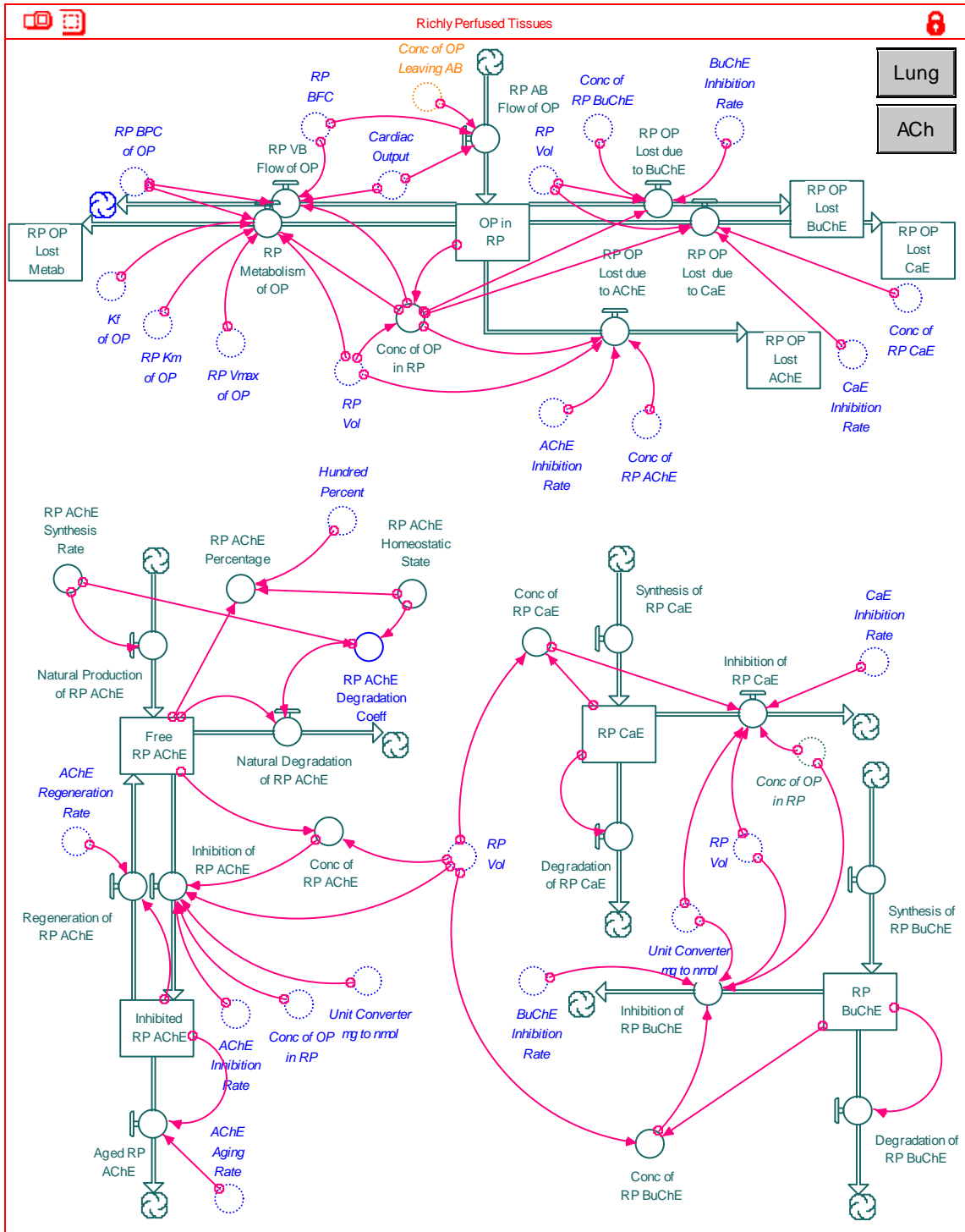

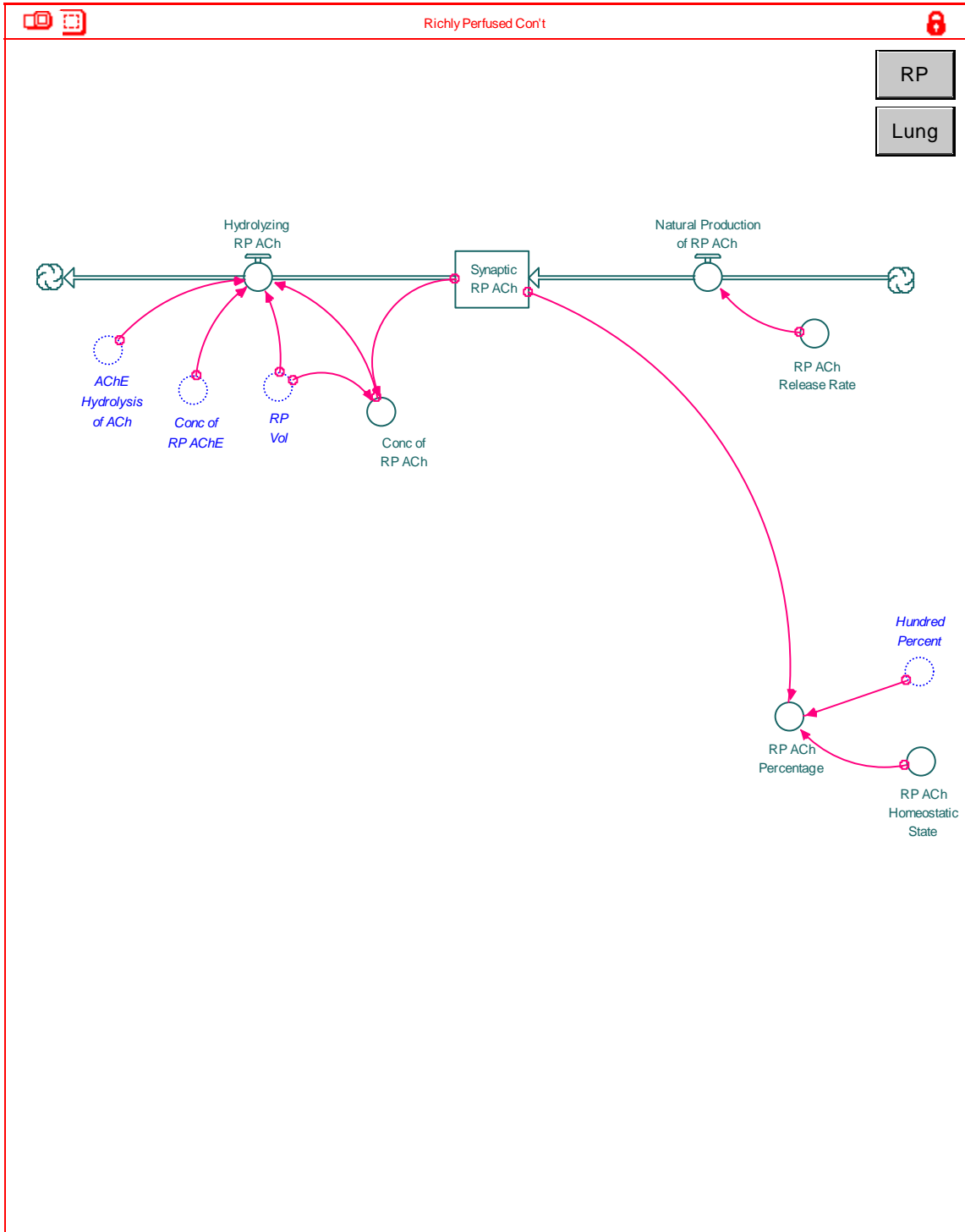

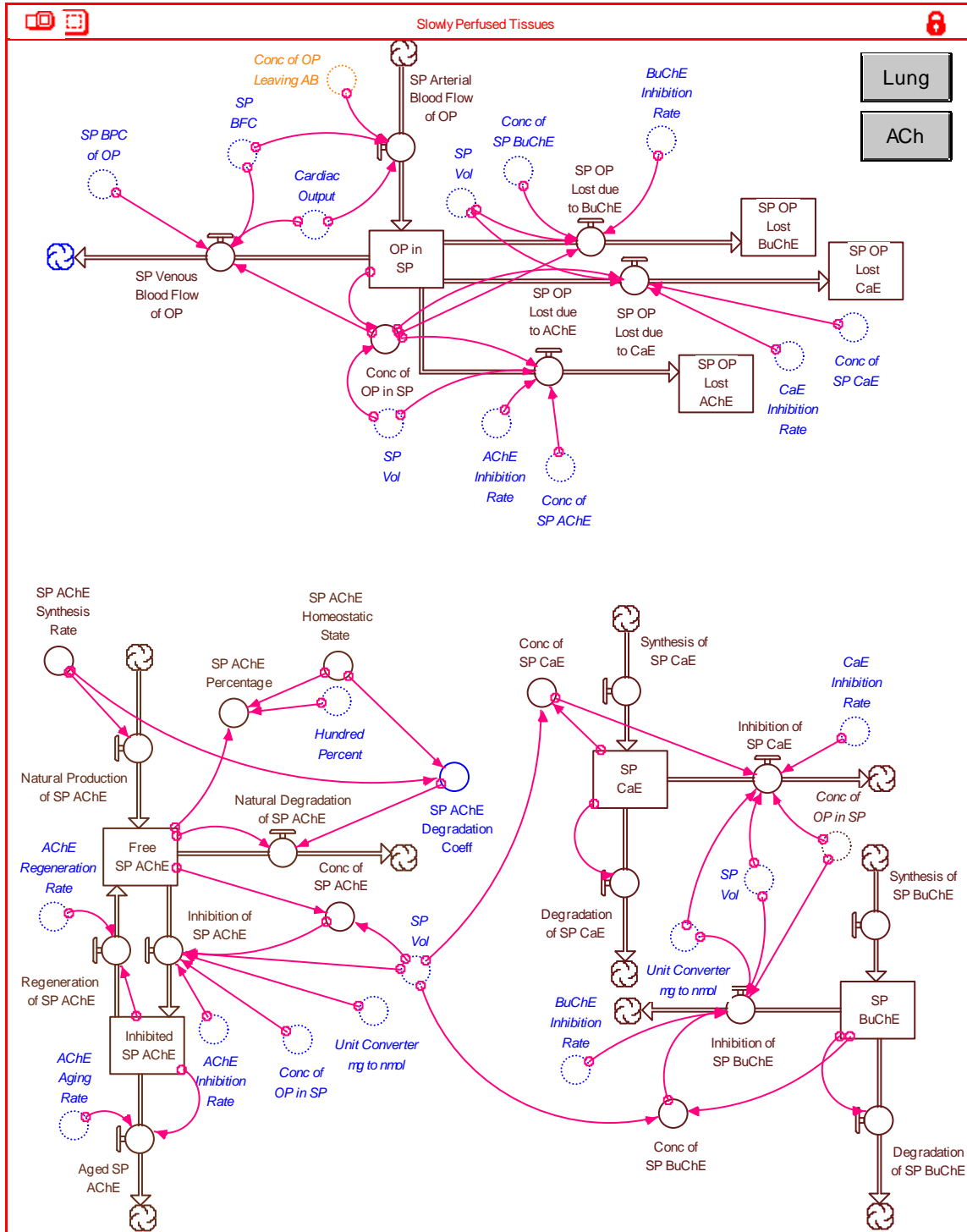

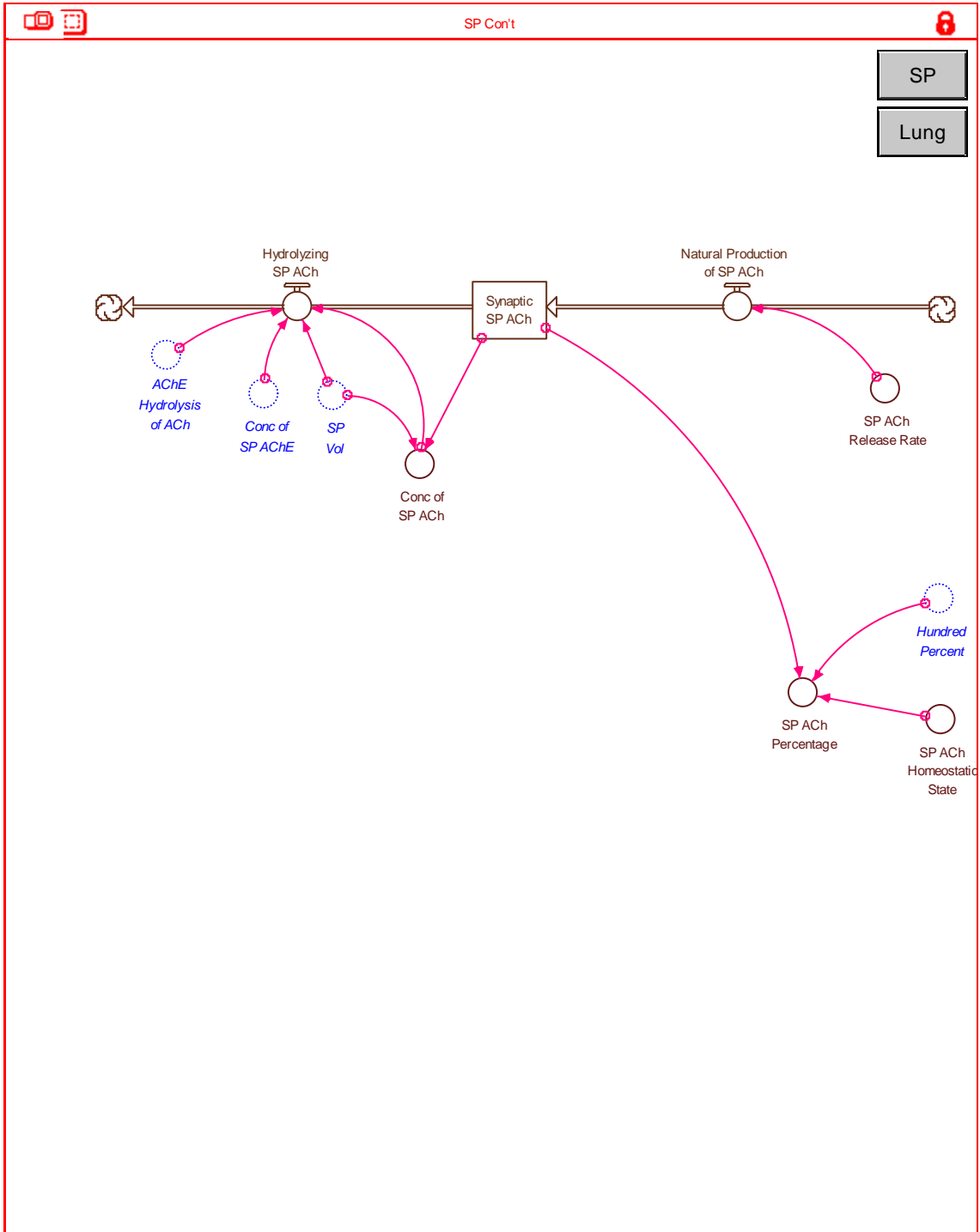

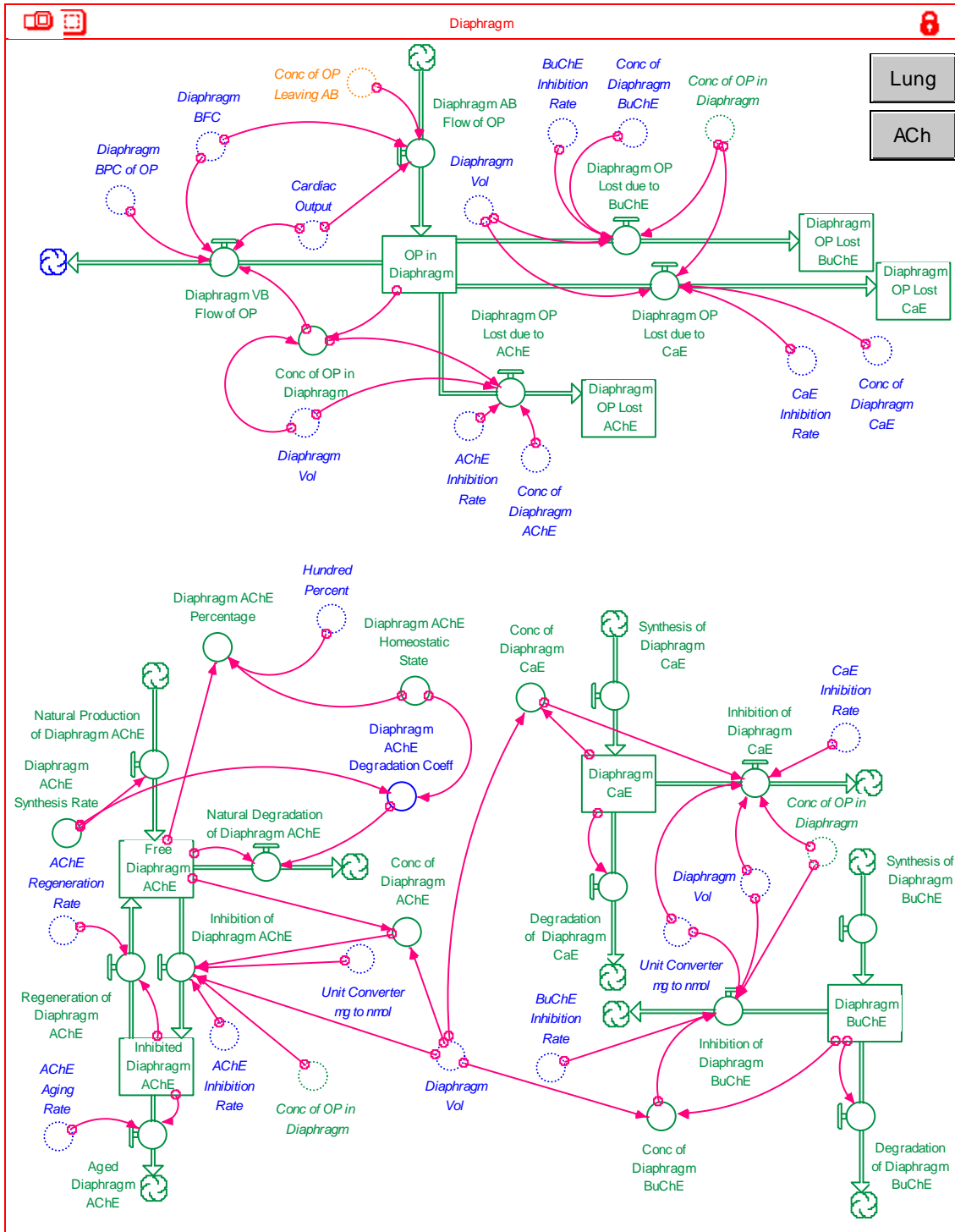

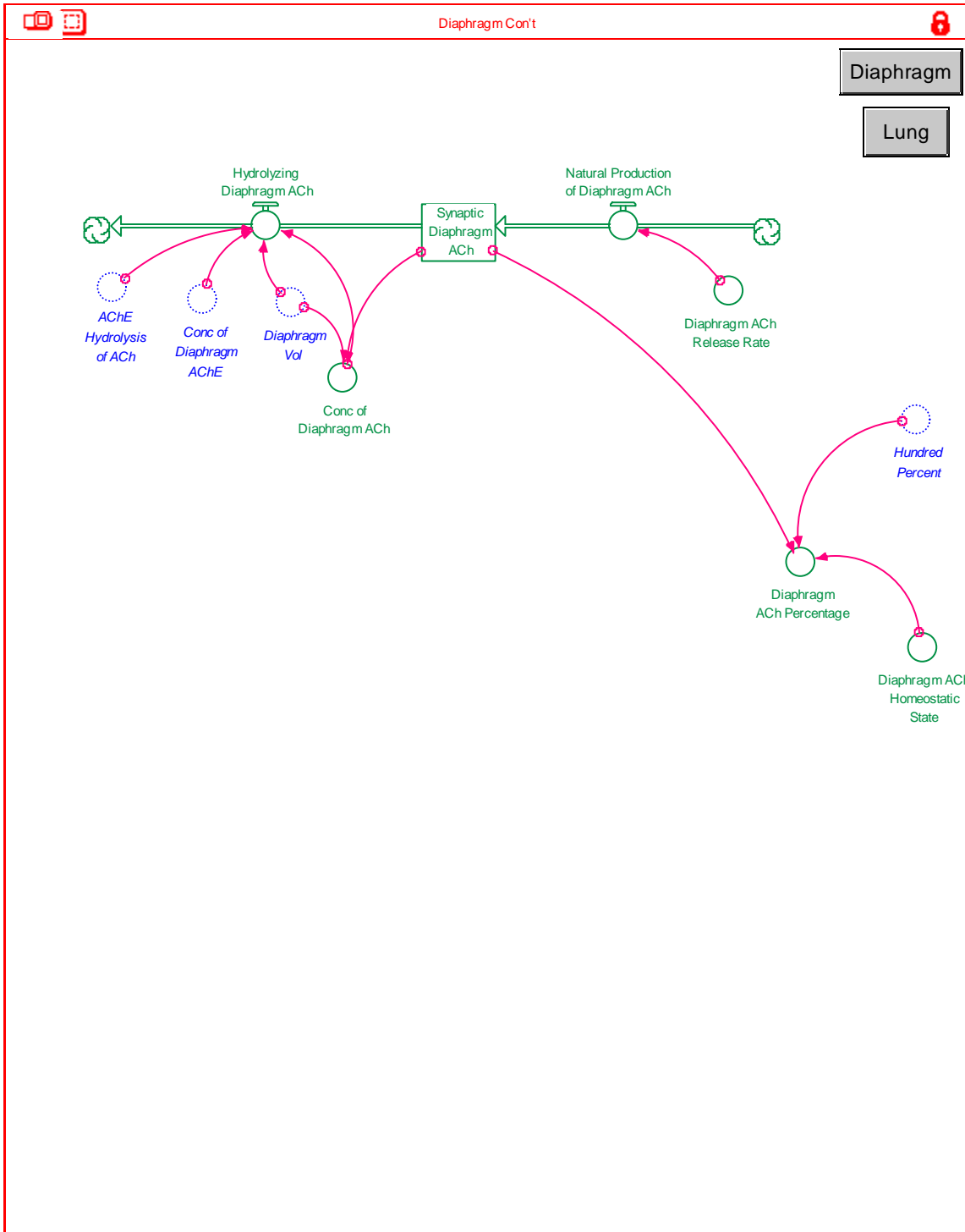

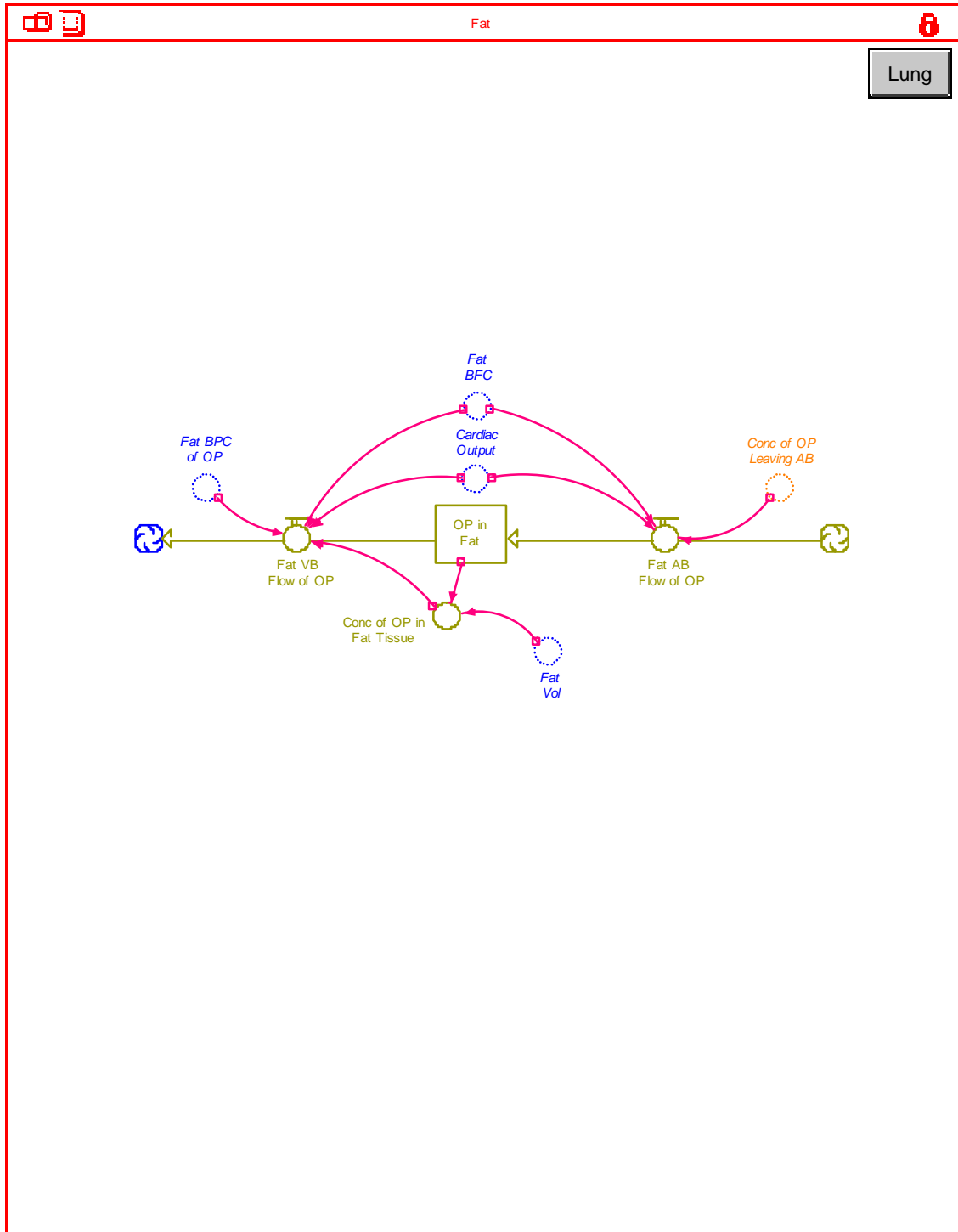

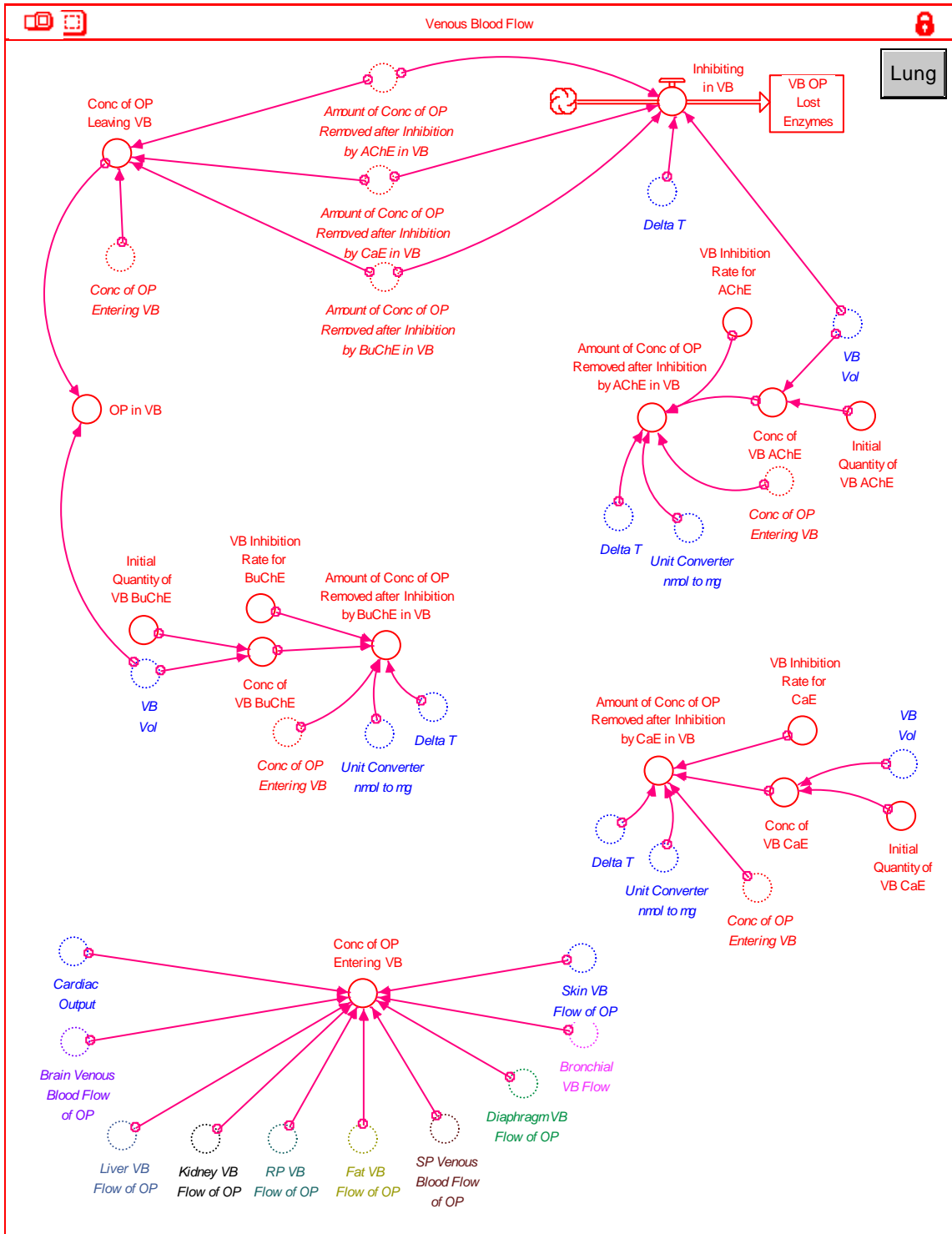

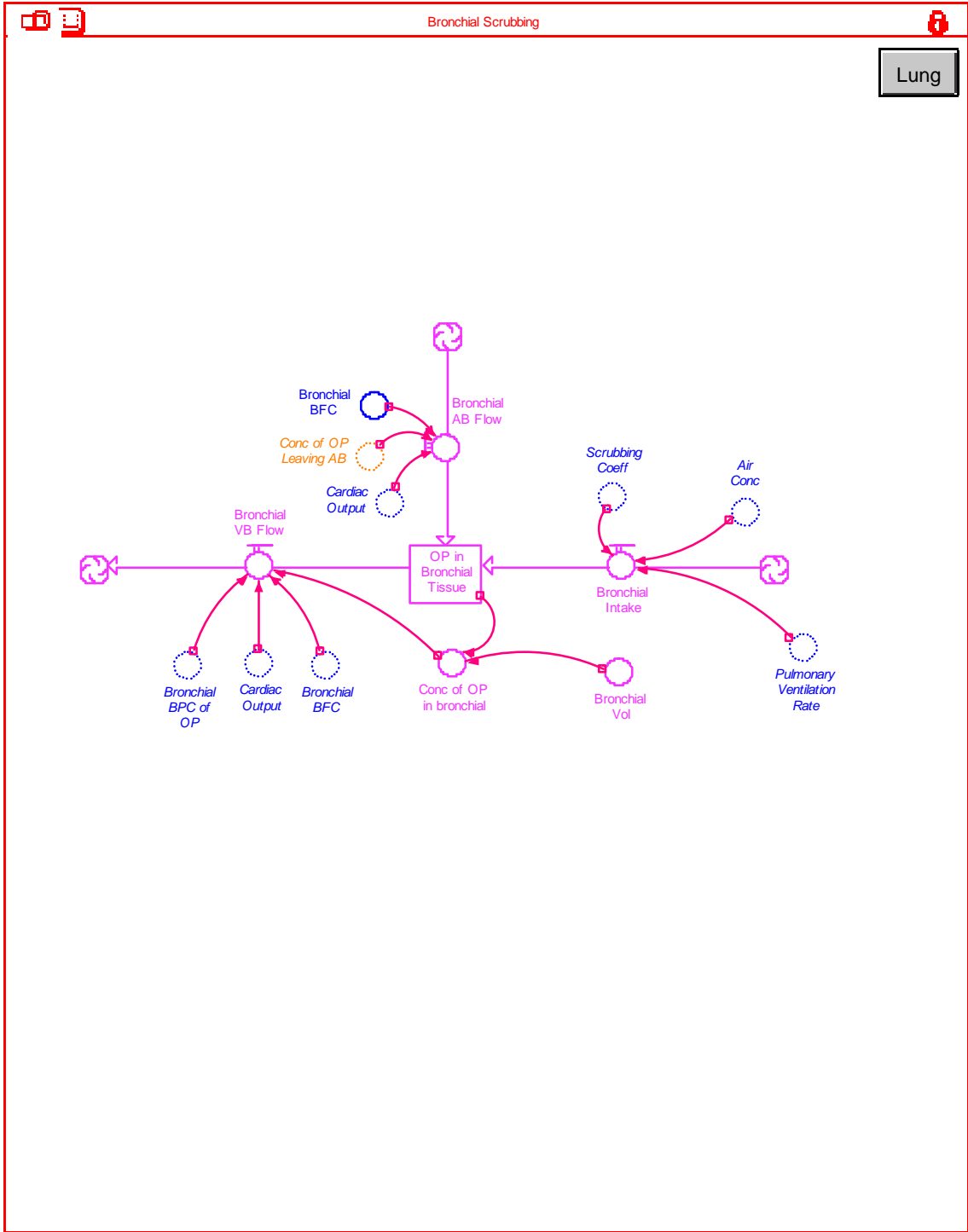

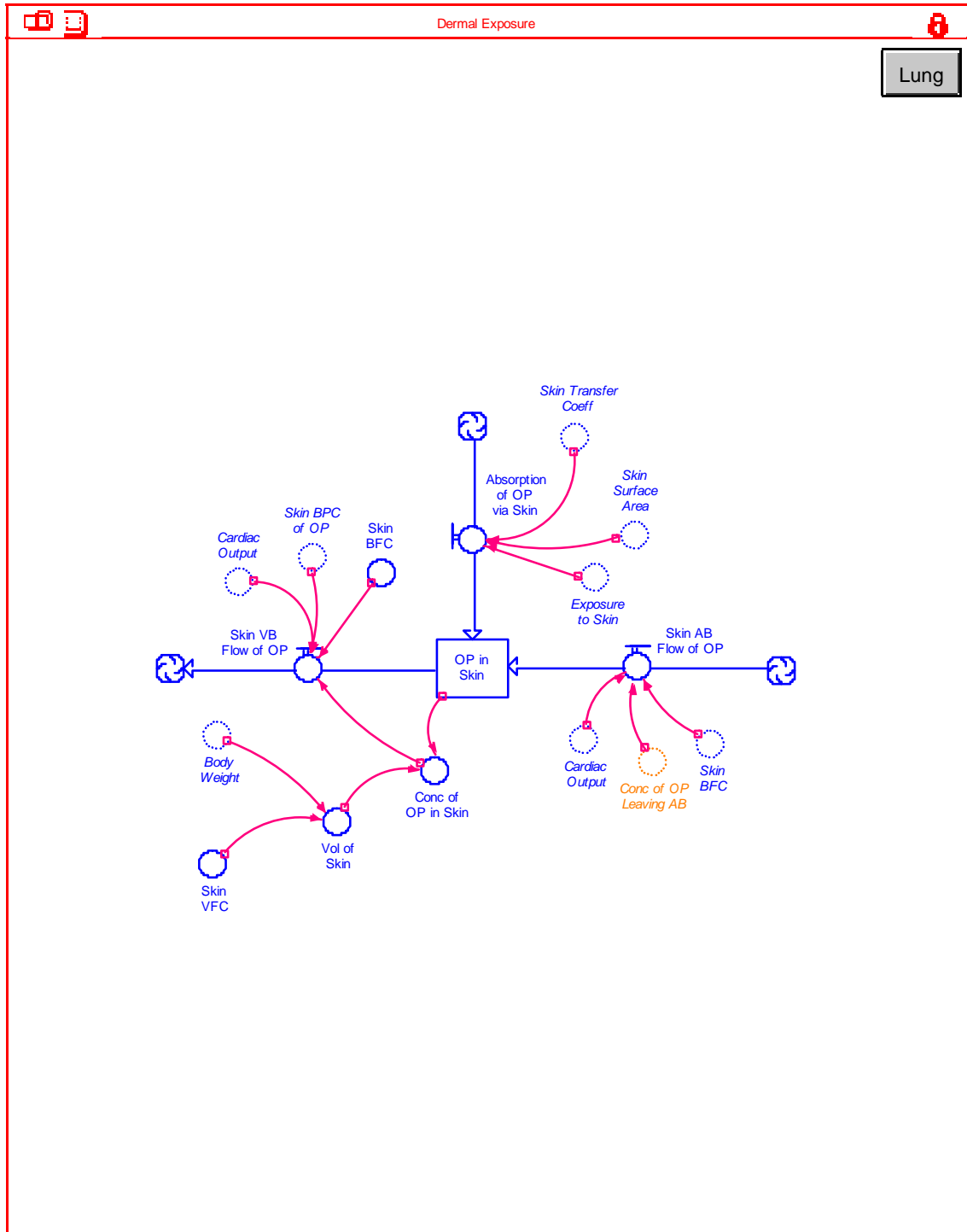

Appendix 2 Model equations

Amount Absorbed

- $Cum_Absorbed_Dose(t) = Cum_Absorbed_Dose(t - dt) + (Dermal_Inflow) * dt$
- $INIT\ Cum_Absorbed_Dose = 0$
- INFLOWS:
 - $Dermal_Inflow = Absorption_of_OP_via_Skin$
- $Cum_Absorbed_Inh_Dose(t) = Cum_Absorbed_Inh_Dose(t - dt) + (Inhalation_Inflow) * dt$
- $INIT\ Cum_Absorbed_Inh_Dose = 0$
- INFLOWS:
 - $Inhalation_Inflow = Cardiac_Output * Conc_of_OP_Entering_AB - Cardiac_Output * Conc_of_OP_Leaving_VB$

Arterial Blood Flow

- $AB_OP_Lost_Enzymes(t) = AB_OP_Lost_Enzymes(t - dt) + (Inhibiting_in_AB) * dt$
- $INIT\ AB_OP_Lost_Enzymes = 0$
- INFLOWS:
 - $Inhibiting_in_AB = ((Amount_of_Conc_of_OP_Removed_after_Inhibition_by_BuChE_in_AB + Amount_of_Conc_of_OP_Removed_after_Inhibition_by_CaE_in_AB + Amount_of_Conc_of_OP_Removed_after_Inhibition_by_AChE_in_AB) * AB_Vol) / Delta_T$
- $AB_Inhibition_Rate_for_CaE = 0.00108$
- $AB_Inhibition_Rate_for_AChE = 0.01416$
- $AB_Inhibition_Rate_for_BuChE = 0.4248$
- $Amount_of_Conc_of_OP_Removed_after_Inhibition_by_BuChE_in_AB = Unit_Converter_nmol_to_mg * AB_Inhibition_Rate_for_BuChE * Conc_of_OP_Entering_AB * Conc_of_AB_BuChE * Delta_T$
- $Amount_of_Conc_of_OP_Removed_after_Inhibition_by_CaE_in_AB = Unit_Converter_nmol_to_mg * AB_Inhibition_Rate_for_CaE * Conc_of_AB_CaE * Conc_of_OP_Entering_AB * Delta_T$
- $Amount_of_Conc_of_OP_Removed_after_Inhibition_by_AChE_in_AB = Unit_Converter_nmol_to_mg * AB_Inhibition_Rate_for_AChE * Conc_of_OP_Entering_AB * Conc_of_AB_AChE * Delta_T$
- $Conc_of_AB_CaE = Initial_Quantity_of_AB_CaE / AB_Vol$
- $Conc_of_OP_Leaving_AB = Conc_of_OP_Entering_AB - Amount_of_Conc_of_OP_Removed_after_Inhibition_by_AChE_in_AB - Amount_of_Conc_of_OP_Removed_after_Inhibition_by_BuChE_in_AB - Amount_of_Conc_of_OP_Removed_after_Inhibition_by_CaE_in_AB$

- $\text{Conc_of_AB_AChE} = \text{Initial_Quantity_of_AB_AChE} / \text{AB_Vol}$
- $\text{Conc_of_AB_BuChE} = \text{Initial_Quantity_of_AB_BuChE} / \text{AB_Vol}$
- $\text{Initial_Quantity_of_AB_AChE} = 1.18826$
- $\text{Initial_Quantity_of_AB_BuChE} = 5.9413$
- $\text{Initial_Quantity_of_AB_CaE} = 4990.69$
- $\text{OP_in_AB} = \text{Conc_of_OP_Leaving_AB} * \text{AB_Vol}$

Blood Fraction Coeff

- $\text{Brain_BFC} = 0.134$
- $\text{Diaphragm_BFC} = 0.006$
- $\text{Fat_BFC} = 0.0360$
- $\text{Kidney_BFC} = 0.2230$
- $\text{Liver_BFC} = 0.2700$
- $\text{RP_BFC} = 0.1583$
- $\text{SP_BFC} = 0.073$

Brain

- $\text{Brain_CaE}(t) = \text{Brain_CaE}(t - dt) + (\text{Synthesis_of_Brain_CaE} - \text{Degradation_of_Brain_CaE} - \text{Inhibition_of_Brain_CaE}) * dt$
- $\text{INIT Brain_CaE} = 780$
- INFLOWS:
 - $\text{Synthesis_of_Brain_CaE} = 15.6$
- OUTFLOWS:
 - $\text{Degradation_of_Brain_CaE} = .02 * \text{Brain_CaE}$
 - $\text{Inhibition_of_Brain_CaE} = \text{CaE_Inhibition_Rate} * \text{Conc_of_Brain_CaE} * \text{Conc_of_OP_in_Brain} * \text{Unit_Converter_mg_to_nmol} * \text{Brain_Vol}$
- $\text{Brain_OP_Lost_AChE}(t) = \text{Brain_OP_Lost_AChE}(t - dt) + (\text{Brain_OP_Lost_due_to_AChE}) * dt$
- $\text{INIT Brain_OP_Lost_AChE} = 0$
- INFLOWS:
 - $\text{Brain_OP_Lost_due_to_AChE} = \text{AChE_Inhibition_Rate} * \text{Conc_of_OP_in_Brain} * \text{Conc_of_Brain_AChE} * \text{Brain_Vol}$
- $\text{Brain_OP_Lost_BuChE}(t) = \text{Brain_OP_Lost_BuChE}(t - dt) + (\text{Brain_OP_Lost_due_to_BuChE}) * dt$
- $\text{INIT Brain_OP_Lost_BuChE} = 0$
- INFLOWS:
 - $\text{Brain_OP_Lost_due_to_BuChE} = \text{BuChE_Inhibition_Rate} * \text{Conc_of_OP_in_Brain} * \text{Conc_of_Brain_BuChE} * \text{Brain_Vol}$
- $\text{Brain_OP_Lost_CaE}(t) = \text{Brain_OP_Lost_CaE}(t - dt) + (\text{Brain_OP_Lost_due_to_CaE}) * dt$
- $\text{INIT Brain_OP_Lost_CaE} = 0$

- INFLOWS:
 - $\text{Brain_OP_Lost_due_to_CaE} = \text{CaE_Inhibition_Rate} * \text{Conc_of_Brain_CaE} * \text{Conc_of_OP_in_Brain} * \text{Brain_Vol}$
- $\text{Brain_OP_Lost_Metab}(t) = \text{Brain_OP_Lost_Metab}(t - dt) + (\text{Brain_Metabolism_of_OP}) * dt$
- INIT $\text{Brain_OP_Lost_Metab} = 0$
- INFLOWS:
 - $\text{Brain_Metabolism_of_OP} = \text{Brain_Vmax_of_OP} * (\text{Conc_of_OP_in_Brain} / \text{Brain_BPC_of_OP}) / (\text{Brain_Km_of_OP} + (\text{Conc_of_OP_in_Brain} / \text{Brain_BPC_of_OP})) + \text{Kf_of_OP} * (\text{Conc_of_OP_in_Brain} / \text{Brain_BPC_of_OP}) * \text{Brain_Vol}$
- $\text{Brain_BuChE}(t) = \text{Brain_BuChE}(t - dt) + (\text{Synthesis_of_Brain_BuChE} - \text{Degradation_of_Brain_BuChE} - \text{Inhibition_of_Brain_BuChE}) * dt$
- INIT $\text{Brain_BuChE} = 16.9$
- INFLOWS:
 - $\text{Synthesis_of_Brain_BuChE} = 0.169$
- OUTFLOWS:
 - $\text{Degradation_of_Brain_BuChE} = \text{Brain_BuChE} * 0.01$
 - $\text{Inhibition_of_Brain_BuChE} = \text{BuChE_Inhibition_Rate} * \text{Conc_of_Brain_BuChE} * \text{Conc_of_OP_in_Brain} * \text{Unit_Converter_mg_to_nmol} * \text{Brain_Vol}$
- $\text{Free_Brain_AChE}(t) = \text{Free_Brain_AChE}(t - dt) + (\text{Natural_Production_of_Brain_AChE} + \text{Regeneration_of_Brain_AChE} - \text{Inhibition_of_Brain_AChE} - \text{Natural_Degradation_of_Brain_AChE}) * dt$
- INIT $\text{Free_Brain_AChE} = 49.4$
- INFLOWS:
 - $\text{Natural_Production_of_Brain_AChE} = \text{Brain_AChE_Synthesis_Rate}$
 - $\text{Regeneration_of_Brain_AChE} = \text{AChE_Regeneration_Rate} * \text{Inhibited_Brain_AChE}$
- OUTFLOWS:
 - $\text{Inhibition_of_Brain_AChE} = \text{AChE_Inhibition_Rate} * \text{Conc_of_Brain_AChE} * \text{Conc_of_OP_in_Brain} * \text{Unit_Converter_mg_to_nmol} * \text{Brain_Vol}$
 - $\text{Natural_Degradation_of_Brain_AChE} = \text{Brain_AChE_Degradation_Coeff} * \text{Free_Brain_AChE}$
- $\text{Inhibited_Brain_AChE}(t) = \text{Inhibited_Brain_AChE}(t - dt) + (\text{Inhibition_of_Brain_AChE} - \text{Regeneration_of_Brain_AChE} - \text{Aged_Brain_AChE}) * dt$
- INIT $\text{Inhibited_Brain_AChE} = 0$
- INFLOWS:
 - $\text{Inhibition_of_Brain_AChE} = \text{AChE_Inhibition_Rate} * \text{Conc_of_Brain_AChE} * \text{Conc_of_OP_in_Brain} * \text{Unit_Converter_mg_to_nmol} * \text{Brain_Vol}$
- OUTFLOWS:
 - $\text{Regeneration_of_Brain_AChE} = \text{AChE_Regeneration_Rate} * \text{Inhibited_Brain_AChE}$

- Aged_Brain_AChE = AChE_Aging_Rate * Inhibited_Brain_AChE
- OP_in_the_Brain(t) = OP_in_the_Brain(t - dt) + (Brain_Arterial_Blood_Flow_of_OP - Brain_Venous_Blood_Flow_of_OP - Brain_Metabolism_of_OP - Brain_OP_Lost_due_to_AChE - Brain_OP_Lost_due_to_CaE - Brain_OP_Lost_due_to_BuChE) * dt
- INIT OP_in_the_Brain = 0
- INFLOWS:
- Brain_Arterial_Blood_Flow_of_OP = Brain_BFC * Conc_of_OP_Leaving_AB * Cardiac_Output
- OUTFLOWS:
 - Brain_Venous_Blood_Flow_of_OP = (Brain_BFC * Cardiac_Output) * (Conc_of_OP_in_Brain / Brain_BPC_of_OP)
 - Brain_Metabolism_of_OP = Brain_Vmax_of_OP * (Conc_of_OP_in_Brain / Brain_BPC_of_OP) / (Brain_Km_of_OP + (Conc_of_OP_in_Brain / Brain_BPC_of_OP)) + Kf_of_OP * (Conc_of_OP_in_Brain / Brain_BPC_of_OP) * Brain_Vol
 - Brain_OP_Lost_due_to_AChE = AChE_Inhibition_Rate * Conc_of_OP_in_Brain * Conc_of_Brain_AChE * Brain_Vol
 - Brain_OP_Lost_due_to_CaE = CaE_Inhibition_Rate * Conc_of_Brain_CaE * Conc_of_OP_in_Brain * Brain_Vol
 - Brain_OP_Lost_due_to_BuChE = BuChE_Inhibition_Rate * Conc_of_OP_in_Brain * Conc_of_Brain_BuChE * Brain_Vol
- Brain_AChE_Degradation_Coeff = Brain_AChE_Synthesis_Rate / Brain_AChE_Homeostatic_State
- Brain_AChE_Homeostatic_State = 49.4
- Brain_AChE_Percentage = (Hundred_Percent / Brain_AChE_Homeostatic_State) * Free_Brain_AChE
- Brain_AChE_Synthesis_Rate = 0.0014
- Conc_of_Brain_AChE = Free_Brain_AChE / Brain_Vol
- Conc_of_Brain_BuChE = Brain_BuChE / Brain_Vol
- Conc_of_Brain_CaE = Brain_CaE / Brain_Vol
- Conc_of_OP_in_Brain = OP_in_the_Brain / Brain_Vol

Brain Con't

- Synaptic_Brain_ACh(t) = Synaptic_Brain_ACh(t - dt) + (Natural_Production_of_Brain_ACh - Hydrolyzing_Brain_ACh) * dt INIT Synaptic_Brain_ACh = 0.100
- INFLOWS:
 - Natural_Production_of_Brain_ACh = Brain_ACh_Release_Rate
- OUTFLOWS:
 - Hydrolyzing_Brain_ACh = AChE_Hydrolysis_of_ACh * Conc_of_Brain_ACh * Brain_Vol * Conc_of_Brain_AChE
- Brain_ACh_Homeostatic_State = 0.100

- $\text{Brain_ACh_Percentage} = (\text{Hundred_Percent} / \text{Brain_ACh_Homeostatic_State}) * \text{Synaptic_Brain_ACh}$
- $\text{Brain_ACh_Release_Rate} = 0.0761852$
- $\text{Conc_of_Brain_ACh} = \text{Synaptic_Brain_ACh} / \text{Brain_Vol}$

Bronchial Scrubbing

- $\text{OP_in_Bronchial_Tissue}(t) = \text{OP_in_Bronchial_Tissue}(t - dt) + (\text{Bronchial_Intake} + \text{Bronchial_AB_Flow} - \text{Bronchial_VB_Flow}) * dt$
- $\text{INIT OP_in_Bronchial_Tissue} = 0$
- INFLOWS:
 - $\text{Bronchial_Intake} = \text{Air_Conc} * \text{Pulmonary_Ventilation_Rate} * \text{Scrubbing_Coeff}$
 - $\text{Bronchial_AB_Flow} = \text{Bronchial_BFC} * \text{Cardiac_Output} * \text{Conc_of_OP_Leaving_AB}$
- OUTFLOWS:
 - $\text{Bronchial_VB_Flow} = \text{Cardiac_Output} * \text{Bronchial_BFC} * (\text{Conc_of_OP_in_bronchial} / \text{Bronchial_BPC_of_OP})$
- $\text{Bronchial_Vol} = .17484$
- $\text{Bronchial_BFC} = 0.0417$
- $\text{Conc_of_OP_in_bronchial} = \text{OP_in_Bronchial_Tissue} / \text{Bronchial_Vol}$

Chemical Coeff

- $\text{Kf_of_OP} = 0$
- $\text{MW} = 184.15$

Dermal Exposure

- $\text{OP_in_Skin}(t) = \text{OP_in_Skin}(t - dt) + (\text{Absorption_of_OP_via_Skin} + \text{Skin_AB_Flow_of_OP} - \text{Skin_VB_Flow_of_OP}) * dt$
- $\text{INIT OP_in_Skin} = 0$
- INFLOWS:
 - $\text{Absorption_of_OP_via_Skin} = \text{Exposure_to_Skin} * \text{Skin_Surface_Area} * \text{Skin_Transfer_Coeff}$
 - $\text{Skin_AB_Flow_of_OP} = \text{Cardiac_Output} * \text{Conc_of_OP_Leaving_AB} * \text{Skin_BFC}$
- OUTFLOWS:
 - $\text{Skin_VB_Flow_of_OP} = \text{Skin_BFC} * \text{Cardiac_Output} * (\text{Conc_of_OP_in_Skin} / \text{Skin_BPC_of_OP})$
- $\text{Conc_of_OP_in_Skin} = \text{OP_in_Skin} / \text{Vol_of_Skin}$
- $\text{Skin_BFC} = 0.058$
- $\text{Skin_VFC} = 0.037$
- $\text{Vol_of_Skin} = \text{Body_Weight} * \text{Skin_VFC}$

Diaphragm

- $\text{Diaphragm_CaE}(t) = \text{Diaphragm_CaE}(t - dt) + (\text{Synthesis_of_Diaphragm_CaE} - \text{Degradation_of_Diaphragm_CaE} - \text{Inhibition_of_Diaphragm_CaE}) * dt$
- $\text{INIT Diaphragm_CaE} = 617.7$
- INFLOWS:
 - $\text{Synthesis_of_Diaphragm_CaE} = 617.7$
- OUTFLOWS:
 - $\text{Degradation_of_Diaphragm_CaE} = \text{Diaphragm_CaE}$
 - $\text{Inhibition_of_Diaphragm_CaE} = \text{CaE_Inhibition_Rate} * \text{Conc_of_Diaphragm_CaE} * \text{Conc_of_OP_in_Diaphragm} * \text{Unit_Converter_mg_to_nmol} * \text{Diaphragm_Vol}$
- $\text{Diaphragm_OP_Lost_AChE}(t) = \text{Diaphragm_OP_Lost_AChE}(t - dt) + (\text{Diaphragm_OP_Lost_due_to_AChE}) * dt$
- $\text{INIT Diaphragm_OP_Lost_AChE} = 0$
- INFLOWS:
 - $\text{Diaphragm_OP_Lost_due_to_AChE} = \text{AChE_Inhibition_Rate} * \text{Conc_of_Diaphragm_AChE} * \text{Conc_of_OP_in_Diaphragm} * \text{Diaphragm_Vol}$
- $\text{Diaphragm_OP_Lost_BuChE}(t) = \text{Diaphragm_OP_Lost_BuChE}(t - dt) + (\text{Diaphragm_OP_Lost_due_to_BuChE}) * dt$
- $\text{INIT Diaphragm_OP_Lost_BuChE} = 0$
- INFLOWS:
 - $\text{Diaphragm_OP_Lost_due_to_BuChE} = \text{BuChE_Inhibition_Rate} * \text{Conc_of_Diaphragm_BuChE} * \text{Conc_of_OP_in_Diaphragm} * \text{Diaphragm_Vol}$
- $\text{Diaphragm_OP_Lost_CaE}(t) = \text{Diaphragm_OP_Lost_CaE}(t - dt) + (\text{Diaphragm_OP_Lost_due_to_CaE}) * dt$
- $\text{INIT Diaphragm_OP_Lost_CaE} = 0$
- INFLOWS:
 - $\text{Diaphragm_OP_Lost_due_to_CaE} = \text{CaE_Inhibition_Rate} * \text{Conc_of_Diaphragm_CaE} * \text{Conc_of_OP_in_Diaphragm} * \text{Diaphragm_Vol}$
- $\text{Diaphragm_BuChE}(t) = \text{Diaphragm_BuChE}(t - dt) + (\text{Synthesis_of_Diaphragm_BuChE} - \text{Degradation_of_Diaphragm_BuChE} - \text{Inhibition_of_Diaphragm_BuChE}) * dt$
- $\text{INIT Diaphragm_BuChE} = 2.343$
- INFLOWS:
 - $\text{Synthesis_of_Diaphragm_BuChE} = 2.343$
- OUTFLOWS:
 - $\text{Degradation_of_Diaphragm_BuChE} = \text{Diaphragm_BuChE}$
 - $\text{Inhibition_of_Diaphragm_BuChE} = \text{BuChE_Inhibition_Rate} * \text{Conc_of_Diaphragm_BuChE} * \text{Conc_of_OP_in_Diaphragm} * \text{Unit_Converter_mg_to_nmol} * \text{Diaphragm_Vol}$

- $\text{Free_Diaphragm_AChE}(t) = \text{Free_Diaphragm_AChE}(t - dt) + (\text{Natural_Production_of_Diaphragm_AChE} + \text{Regeneration_of_Diaphragm_AChE} - \text{Inhibition_of_Diaphragm_AChE} - \text{Natural_Degradation_of_Diaphragm_AChE}) * dt$
- $\text{INIT Free_Diaphragm_AChE} = 1.065$
- INFLOWS:
 - $\text{Natural_Production_of_Diaphragm_AChE} = \text{Diaphragm_AChE_Synthesis_Rate}$
 - $\text{Regeneration_of_Diaphragm_AChE} = \text{AChE_Regeneration_Rate} * \text{Inhibited_Diaphragm_AChE}$
- OUTFLOWS:
 - $\text{Inhibition_of_Diaphragm_AChE} = \text{AChE_Inhibition_Rate} * \text{Conc_of_Diaphragm_AChE} * \text{Conc_of_OP_in_Diaphragm} * \text{Unit_Converter_mg_to_nmol} * \text{Diaphragm_Vol}$
 - $\text{Natural_Degradation_of_Diaphragm_AChE} = \text{Diaphragm_AChE_Degradation_Coeff} * \text{Free_Diaphragm_AChE}$
- $\text{Inhibited_Diaphragm_AChE}(t) = \text{Inhibited_Diaphragm_AChE}(t - dt) + (\text{Inhibition_of_Diaphragm_AChE} - \text{Regeneration_of_Diaphragm_AChE} - \text{Aged_Diaphragm_AChE}) * dt$
- $\text{INIT Inhibited_Diaphragm_AChE} = 0$
- INFLOWS:
 - $\text{Inhibition_of_Diaphragm_AChE} = \text{AChE_Inhibition_Rate} * \text{Conc_of_Diaphragm_AChE} * \text{Conc_of_OP_in_Diaphragm} * \text{Unit_Converter_mg_to_nmol} * \text{Diaphragm_Vol}$
- OUTFLOWS:
 - $\text{Regeneration_of_Diaphragm_AChE} = \text{AChE_Regeneration_Rate} * \text{Inhibited_Diaphragm_AChE}$
 - $\text{Aged_Diaphragm_AChE} = \text{AChE_Aging_Rate} * \text{Inhibited_Diaphragm_AChE}$
- $\text{OP_in_Diaphragm}(t) = \text{OP_in_Diaphragm}(t - dt) + (\text{Diaphragm_AB_Flow_of_OP} - \text{Diaphragm_VB_Flow_of_OP} - \text{Diaphragm_OP_Lost_due_to_AChE} - \text{Diaphragm_OP_Lost_due_to_CaE} - \text{Diaphragm_OP_Lost_due_to_BuChE}) * dt$
- $\text{INIT OP_in_Diaphragm} = 0$
- INFLOWS:
 - $\text{Diaphragm_AB_Flow_of_OP} = \text{Cardiac_Output} * \text{Diaphragm_BFC} * \text{Conc_of_OP_Leaving_AB}$
- OUTFLOWS:
 - $\text{Diaphragm_VB_Flow_of_OP} = \text{Diaphragm_BFC} * \text{Cardiac_Output} * (\text{Conc_of_OP_in_Diaphragm} / \text{Diaphragm_BPC_of_OP})$
 - $\text{Diaphragm_OP_Lost_due_to_AChE} = \text{AChE_Inhibition_Rate} * \text{Conc_of_Diaphragm_AChE} * \text{Conc_of_OP_in_Diaphragm} * \text{Diaphragm_Vol}$
 - $\text{Diaphragm_OP_Lost_due_to_CaE} = \text{CaE_Inhibition_Rate} * \text{Conc_of_Diaphragm_CaE} * \text{Conc_of_OP_in_Diaphragm} * \text{Diaphragm_Vol}$
 - $\text{Diaphragm_OP_Lost_due_to_BuChE} = \text{BuChE_Inhibition_Rate} * \text{Conc_of_Diaphragm_BuChE} * \text{Conc_of_OP_in_Diaphragm} * \text{Diaphragm_Vol}$

- $\text{Conc_of_Diaphragm_AChE} = \text{Free_Diaphragm_AChE} / \text{Diaphragm_Vol}$
- $\text{Conc_of_Diaphragm_BuChE} = \text{Diaphragm_BuChE} / \text{Diaphragm_Vol}$
- $\text{Conc_of_Diaphragm_CaE} = \text{Diaphragm_CaE} / \text{Diaphragm_Vol}$
- $\text{Conc_of_OP_in_Diaphragm} = \text{OP_in_Diaphragm} / \text{Diaphragm_Vol}$
- $\text{Diaphragm_AChE_Degradation_Coeff} = \text{Diaphragm_AChE_Synthesis_Rate} / \text{Diaphragm_AChE_Homeostatic_State}$
- $\text{Diaphragm_AChE_Homeostatic_State} = 1.065$
- $\text{Diaphragm_AChE_Percentage} = (\text{Hundred_Percent} / \text{Diaphragm_AChE_Homeostatic_State}) * \text{Free_Diaphragm_AChE}$
- $\text{Diaphragm_AChE_Synthesis_Rate} = 0.053$

Diaphragm Con't

- $\text{Synaptic_Diaphragm_ACh}(t) = \text{Synaptic_Diaphragm_ACh}(t - dt) + (\text{Natural_Production_of_Diaphragm_ACh} - \text{Hydrolyzing_Diaphragm_ACh}) * dt$
- $\text{INIT Synaptic_Diaphragm_ACh} = 0.100$
- INFLOWS:
 - $\text{Natural_Production_of_Diaphragm_ACh} = \text{Diaphragm_ACh_Release_Rate}$
- OUTFLOWS:
 - $\text{Hydrolyzing_Diaphragm_ACh} = \text{AChE_Hydrolysis_of_ACh} * \text{Conc_of_Diaphragm_ACh} * \text{Conc_of_Diaphragm_AChE} * \text{Diaphragm_Vol}$
- $\text{Conc_of_Diaphragm_ACh} = \text{Synaptic_Diaphragm_ACh} / \text{Diaphragm_Vol}$
- $\text{Diaphragm_ACh_Homeostatic_State} = 0.100$
- $\text{Diaphragm_ACh_Percentage} = (\text{Hundred_Percent} / \text{Diaphragm_ACh_Homeostatic_State}) * \text{Synaptic_Diaphragm_ACh}$
- $\text{Diaphragm_ACh_Release_Rate} = 0.0117162$

Fat

- $\text{OP_in_Fat}(t) = \text{OP_in_Fat}(t - dt) + (\text{Fat_AB_Flow_of_OP} - \text{Fat_VB_Flow_of_OP}) * dt$
 $\text{INIT OP_in_Fat} = 0$
- INFLOWS:
 - $\text{Fat_AB_Flow_of_OP} = \text{Cardiac_Output} * \text{Fat_BFC} * \text{Conc_of_OP_Leaving_AB}$
- OUTFLOWS:
 - $\text{Fat_VB_Flow_of_OP} = \text{Fat_BFC} * \text{Cardiac_Output} * (\text{Conc_of_OP_in_Fat_Tissue} / \text{Fat_BPC_of_OP})$
- $\text{Conc_of_OP_in_Fat_Tissue} = \text{OP_in_Fat} / \text{Fat_Vol}$

Flow Constants

- $\text{Cardiac_Output} = \text{Cardiac_Flow} * \text{Body_Weight} ^ 0.74$
- $\text{GI_Flow_Const} = 0$
- $\text{Pulmonary_Ventilation_Rate} = \text{Pulmonary_Flow} * \text{Body_Weight} ^ 0.74$

Kidney

- $\text{Free_Kidney_AChE}(t) = \text{Free_Kidney_AChE}(t - dt) + (\text{Natural_Production_of_Kidney_AChE} + \text{Regeneration_of_Kidney_AChE} - \text{Inhibition_of_Kidney_AChE} - \text{Natural_Degradation_of_Kidney_AChE}) * dt$
- $\text{INIT Free_Kidney_AChE} = 0.13322$
- INFLOWS:
 - $\text{Natural_Production_of_Kidney_AChE} = \text{Kidney_AChE_Synthesis_Rate}$
 - $\text{Regeneration_of_Kidney_AChE} = \text{AChE_Regeneration_Rate} * \text{Inhibited_Kidney_AChE}$
- OUTFLOWS:
 - $\text{Inhibition_of_Kidney_AChE} = \text{AChE_Inhibition_Rate} * \text{Conc_of_Kidney_AChE} * \text{Conc_of_OP_in_Kidney} * \text{Unit_Converter_mg_to_nmol} * \text{Kidney_Vol}$
 - $\text{Natural_Degradation_of_Kidney_AChE} = \text{Kidney_AChE_Degradation_Coeff} * \text{Free_Kidney_AChE}$
- $\text{Inhibited_Kidney_AChE}(t) = \text{Inhibited_Kidney_AChE}(t - dt) + (\text{Inhibition_of_Kidney_AChE} - \text{Regeneration_of_Kidney_AChE} - \text{Aged_Kidney_AChE}) * dt$
- $\text{INIT Inhibited_Kidney_AChE} = 0$
- INFLOWS:
 - $\text{Inhibition_of_Kidney_AChE} = \text{AChE_Inhibition_Rate} * \text{Conc_of_Kidney_AChE} * \text{Conc_of_OP_in_Kidney} * \text{Unit_Converter_mg_to_nmol} * \text{Kidney_Vol}$
- OUTFLOWS:
 - $\text{Regeneration_of_Kidney_AChE} = \text{AChE_Regeneration_Rate} * \text{Inhibited_Kidney_AChE}$
 - $\text{Aged_Kidney_AChE} = \text{AChE_Aging_Rate} * \text{Inhibited_Kidney_AChE}$
- $\text{Kidney_BuChE}(t) = \text{Kidney_BuChE}(t - dt) + (\text{Synthesis_of_Kidney_BuChE} - \text{Degradation_of_Kidney_BuChE} - \text{Inhibition_of_Kidney_BuChE}) * dt$
- $\text{INIT Kidney_BuChE} = 0.84$
- INFLOWS:
 - $\text{Synthesis_of_Kidney_BuChE} = 0.84$
- OUTFLOWS:
 - $\text{Degradation_of_Kidney_BuChE} = \text{Kidney_BuChE}$
 - $\text{Inhibition_of_Kidney_BuChE} = \text{BuChE_Inhibition_Rate} * \text{Conc_of_Kidney_BuChE} * \text{Conc_of_OP_in_Kidney} * \text{Unit_Converter_mg_to_nmol} * \text{Kidney_Vol}$
- $\text{Kidney_CaE}(t) = \text{Kidney_CaE}(t - dt) + (\text{Synthesis_of_Kidney_CaE} - \text{Inhibition_of_Kidney_CaE} - \text{Degradation_of_Kidney_CaE}) * dt$
- $\text{INIT Kidney_CaE} = 4620$
- INFLOWS:
 - $\text{Synthesis_of_Kidney_CaE} = 4620$

- OUTFLOWS:
 - $\text{Inhibition_of_Kidney_CaE} = \text{CaE_Inhibition_Rate} * \text{Conc_of_Kidney_CaE} * \text{Conc_of_OP_in_Kidney} * \text{Unit_Converter_mg_to_nmol} * \text{Kidney_Vol}$
 - $\text{Degradation_of_Kidney_CaE} = \text{Kidney_CaE}$
- $\text{Kidney_OP_Lost_AChE}(t) = \text{Kidney_OP_Lost_AChE}(t - dt) + (\text{Kidney_OP_Lost_due_to_AChE}) * dt$
- $\text{INIT Kidney_OP_Lost_AChE} = 0$
- INFLOWS:
 - $\text{Kidney_OP_Lost_due_to_AChE} = \text{AChE_Inhibition_Rate} * \text{Conc_of_Kidney_AChE} * \text{Conc_of_OP_in_Kidney} * \text{Kidney_Vol}$
- $\text{Kidney_OP_Lost_BuChE}(t) = \text{Kidney_OP_Lost_BuChE}(t - dt) + (\text{Kidney_OP_Lost_due_to_BuChE}) * dt$
- $\text{INIT Kidney_OP_Lost_BuChE} = 0$
- INFLOWS:
 - $\text{Kidney_OP_Lost_due_to_BuChE} = \text{BuChE_Inhibition_Rate} * \text{Conc_of_Kidney_BuChE} * \text{Conc_of_OP_in_Kidney} * \text{Kidney_Vol}$
- $\text{Kidney_OP_Lost_CaE}(t) = \text{Kidney_OP_Lost_CaE}(t - dt) + (\text{Kidney_OP_Lost_due_to_CaE}) * dt$
- $\text{INIT Kidney_OP_Lost_CaE} = 0$
- INFLOWS:
 - $\text{Kidney_OP_Lost_due_to_CaE} = \text{CaE_Inhibition_Rate} * \text{Conc_of_Kidney_CaE} * \text{Conc_of_OP_in_Kidney} * \text{Kidney_Vol}$
- $\text{Kidney_OP_Lost_Metab}(t) = \text{Kidney_OP_Lost_Metab}(t - dt) + (\text{Kidney_Metabolism_of_OP}) * dt$
- $\text{INIT Kidney_OP_Lost_Metab} = 0$
- INFLOWS:
 - $\text{Kidney_Metabolism_of_OP} = \text{Kidney_Vmax_of_OP} * (\text{Conc_of_OP_in_Kidney} / \text{Kidney_BPC_of_OP}) / (\text{Kidney_Km_of_OP} + (\text{Conc_of_OP_in_Kidney} / \text{Kidney_BPC_of_OP})) + \text{Kf_of_OP} * (\text{Conc_of_OP_in_Kidney} / \text{Kidney_BPC_of_OP}) * \text{Kidney_Vol}$
- $\text{OP_in_Kidney}(t) = \text{OP_in_Kidney}(t - dt) + (\text{Kidney_AB_Flow_of_OP} - \text{Kidney_VB_Flow_of_OP} - \text{Kidney_Metabolism_of_OP} - \text{Kidney_OP_Lost_due_to_AChE} - \text{Kidney_OP_Lost_due_to_BuChE} - \text{Kidney_OP_Lost_due_to_CaE}) * dt$
- $\text{INIT OP_in_Kidney} = 0$
- INFLOWS:
 - $\text{Kidney_AB_Flow_of_OP} = \text{Cardiac_Output} * \text{Kidney_BFC} * \text{Conc_of_OP_Leaving_AB}$
- OUTFLOWS:
 - $\text{Kidney_VB_Flow_of_OP} = (\text{Kidney_BFC} * \text{Cardiac_Output}) * (\text{Conc_of_OP_in_Kidney} / \text{Kidney_BPC_of_OP})$

- $Kidney_Metabolism_of_OP = Kidney_Vmax_of_OP * (Conc_of_OP_in_Kidney / Kidney_BPC_of_OP) / (Kidney_Km_of_OP + (Conc_of_OP_in_Kidney / Kidney_BPC_of_OP)) + Kf_of_OP * (Conc_of_OP_in_Kidney / Kidney_BPC_of_OP) * Kidney_Vol$
- $Kidney_OP_Lost_due_to_AChE = AChE_Inhibition_Rate * Conc_of_Kidney_AChE * Conc_of_OP_in_Kidney * Kidney_Vol$
- $Kidney_OP_Lost_due_to_BuChE = BuChE_Inhibition_Rate * Conc_of_Kidney_BuChE * Conc_of_OP_in_Kidney * Kidney_Vol$
- $Kidney_OP_Lost_due_to_CaE = CaE_Inhibition_Rate * Conc_of_Kidney_CaE * Conc_of_OP_in_Kidney * Kidney_Vol$
- $Conc_of_Kidney_AChE = Free_Kidney_AChE / Kidney_Vol$
- $Conc_of_Kidney_BuChE = Kidney_BuChE / Kidney_Vol$
- $Conc_of_Kidney_CaE = Kidney_CaE / Kidney_Vol$
- $Conc_of_OP_in_Kidney = OP_in_Kidney / Kidney_Vol$
- $Kidney_AChE_Degradation_Coeff = Kidney_AChE_Synthesis_Rate / Kidney_AChE_Homeostatic_State$
- $Kidney_AChE_Homeostatic_State = .13322$
- $Kidney_AChE_Percentage = (Hundred_Percent / Kidney_AChE_Homeostatic_State) * Free_Kidney_AChE$
- $Kidney_AChE_Synthesis_Rate = 0.053$

Kidney Con't

- $Synaptic_Kidney_ACh(t) = Synaptic_Kidney_ACh(t - dt) + (Natural_Production_of_Kidney_ACh - Hydrolyzing_Kidney_ACh) * dtINIT$
 $Synaptic_Kidney_ACh = 0.100$
- INFLOWS:
 - $Natural_Production_of_Kidney_ACh = Kidney_ACh_Release_Rate$
- OUTFLOWS:
 - $Hydrolyzing_Kidney_ACh = AChE_Hydrolysis_of_ACh * Conc_of_Kidney_ACh * Conc_of_Kidney_AChE * Kidney_Vol$
- $Conc_of_Kidney_ACh = Synaptic_Kidney_ACh / Kidney_Vol$
- $Kidney_ACh_Homeostatic_State = 0.100$
- $Kidney_ACh_Percentage = (Hundred_Percent / Kidney_ACh_Homeostatic_State) * Synaptic_Kidney_ACh$
- $Kidney_ACh_Release_Rate = 0.001022492$

Liver

- $Free_Liver_AChE(t) = Free_Liver_AChE(t - dt) + (Natural_Production_of_Liver_AChE + Regeneration_of_Liver_AChE - Inhibition_of_Liver_AChE - Natural_Degradation_of_Liver_AChE) * dt$
- $INIT\ Free_Liver_AChE = 1.5$

- INFLOWS:
 - Natural_Production_of_Liver_AChE = Liver_AChE_Synthesis_Rate
 - Regeneration_of_Liver_AChE = AChE_Regeneration_Rate * Inhibited_Liver_AChE
- OUTFLOWS:
 - Inhibition_of_Liver_AChE = AChE_Inhibition_Rate * Conc_of_Liver_AChE * Conc_of_OP_Liver_Tissue * Unit_Converter_mg_to_nmol * Liver_Vol
 - Natural_Degradation_of_Liver_AChE = Liver_AChE_Degradation_Coeff * Free_Liver_AChE
- $\text{Inhibited_Liver_AChE}(t) = \text{Inhibited_Liver_AChE}(t - dt) + (\text{Inhibition_of_Liver_AChE} - \text{Regeneration_of_Liver_AChE} - \text{Aged_Liver_AChE}) * dt$
- INIT Inhibited_Liver_AChE = 0
- INFLOWS:
 - Inhibition_of_Liver_AChE = AChE_Inhibition_Rate * Conc_of_Liver_AChE * Conc_of_OP_Liver_Tissue * Unit_Converter_mg_to_nmol * Liver_Vol
- OUTFLOWS:
 - Regeneration_of_Liver_AChE = AChE_Regeneration_Rate * Inhibited_Liver_AChE
 - Aged_Liver_AChE = AChE_Aging_Rate * Inhibited_Liver_AChE
- $\text{Liver_BuChE}(t) = \text{Liver_BuChE}(t - dt) + (\text{Synthesis_of_Liver_BuChE} - \text{Inhibition_of_Liver_BuChE} - \text{Degradation_of_Liver_BuChE}) * dt$
- INIT Liver_BuChE = 12
- INFLOWS:
 - Synthesis_of_Liver_BuChE = .24
- OUTFLOWS:
 - Inhibition_of_Liver_BuChE = BuChE_Inhibition_Rate * Conc_of_OP_Liver_Tissue * Conc_of_Liver_BuChE * Unit_Converter_mg_to_nmol * Liver_Vol
 - Degradation_of_Liver_BuChE = 0.02 * Liver_BuChE
- $\text{Liver_CaE}(t) = \text{Liver_CaE}(t - dt) + (\text{Synthesis_of_Liver_CaE} - \text{Inhibition_of_Liver_CaE} - \text{Degradation_of_Liver_CaE}) * dt$
- INIT Liver_CaE = 68250
- INFLOWS:
 - Synthesis_of_Liver_CaE = 136.5
- OUTFLOWS:
 - Inhibition_of_Liver_CaE = CaE_Inhibition_Rate * Conc_of_Liver_CaE * Conc_of_OP_Liver_Tissue * Unit_Converter_mg_to_nmol * Liver_Vol
 - Degradation_of_Liver_CaE = 0.002 * Liver_CaE
- $\text{Liver_OP_Lost_AChE}(t) = \text{Liver_OP_Lost_AChE}(t - dt) + (\text{Liver_OP_Lost_due_to_AChE}) * dt$
- INIT Liver_OP_Lost_AChE = 0

- INFLOWS:
 - $Liver_OP_Lost_due_to_AChE = AChE_Inhibition_Rate * Conc_of_Liver_AChE * Conc_of_OP_Liver_Tissue * Liver_Vol$
- $Liver_Op_Lost_BuChE(t) = Liver_Op_Lost_BuChE(t - dt) + (Liver_OP_Lost_due_to_BuChE) * dt$
- INIT $Liver_Op_Lost_BuChE = 0$
- INFLOWS:
 - $Liver_OP_Lost_due_to_BuChE = BuChE_Inhibition_Rate * Conc_of_OP_Liver_Tissue * Conc_of_Liver_BuChE * Liver_Vol$
- $Liver_OP_Lost_CaE(t) = Liver_OP_Lost_CaE(t - dt) + (Liver_OP_Lost_due_to_CaE) * dt$
- INIT $Liver_OP_Lost_CaE = 0$
- INFLOWS:
 - $Liver_OP_Lost_due_to_CaE = CaE_Inhibition_Rate * Conc_of_Liver_CaE * Conc_of_OP_Liver_Tissue * Liver_Vol$
- $Liver_OP_Lost_Metab(t) = Liver_OP_Lost_Metab(t - dt) + (Liver_Metabolism_of_OP) * dt$
- INIT $Liver_OP_Lost_Metab = 0$
- INFLOWS:
 - $Liver_Metabolism_of_OP = Liver_Vmax_of_OP * (Conc_of_OP_Liver_Tissue / Liver_BPC_of_OP) / (Liver_Km_of_OP + (Conc_of_OP_Liver_Tissue / Liver_BPC_of_OP)) + Kf_of_OP * (Conc_of_OP_Liver_Tissue / Liver_BPC_of_OP) * Liver_Vol$
- $OP_in_the_Liver(t) = OP_in_the_Liver(t - dt) + (Liver_AB_Flow_of_OP - Liver_VB_Flow_of_OP - Liver_Metabolism_of_OP - Liver_OP_Lost_due_to_AChE - Liver_OP_Lost_due_to_BuChE - Liver_OP_Lost_due_to_CaE) * dt$
- INIT $OP_in_the_Liver = 0$
- INFLOWS:
 - $Liver_AB_Flow_of_OP = Cardiac_Output * Liver_BFC * Conc_of_OP_Leaving_AB$
- OUTFLOWS:
 - $Liver_VB_Flow_of_OP = (Liver_BFC * Cardiac_Output) * (Conc_of_OP_Liver_Tissue / Liver_BPC_of_OP)$
 - $Liver_Metabolism_of_OP = Liver_Vmax_of_OP * (Conc_of_OP_Liver_Tissue / Liver_BPC_of_OP) / (Liver_Km_of_OP + (Conc_of_OP_Liver_Tissue / Liver_BPC_of_OP)) + Kf_of_OP * (Conc_of_OP_Liver_Tissue / Liver_BPC_of_OP) * Liver_Vol$
 - $Liver_OP_Lost_due_to_AChE = AChE_Inhibition_Rate * Conc_of_Liver_AChE * Conc_of_OP_Liver_Tissue * Liver_Vol$
 - $Liver_OP_Lost_due_to_BuChE = BuChE_Inhibition_Rate * Conc_of_OP_Liver_Tissue * Conc_of_Liver_BuChE * Liver_Vol$
 - $Liver_OP_Lost_due_to_CaE = CaE_Inhibition_Rate * Conc_of_Liver_CaE * Conc_of_OP_Liver_Tissue * Liver_Vol$
- $Conc_of_Liver_AChE = Free_Liver_AChE / Liver_Vol$

- $\text{Conc_of_Liver_CaE} = \text{Liver_CaE} / \text{Liver_Vol}$
- $\text{Conc_of_OP_Liver_Tissue} = \text{OP_in_the_Liver} / \text{Liver_Vol}$
- $\text{Conc_of_Liver_BuChE} = \text{Liver_BuChE} / \text{Liver_Vol}$
- $\text{Liver_AChE_Degradation_Coeff} = \text{Liver_AChE_Synthesis_Rate} / \text{Liver_AChE_Homeostatic_State}$
- $\text{Liver_AChE_Homeostatic_State} = 1.5$
- $\text{Liver_AChE_Percentage} = (\text{Hundred_Percent} / \text{Liver_AChE_Homeostatic_State}) * \text{Free_Liver_AChE}$
- $\text{Liver_AChE_Synthesis_Rate} = 0.053$

Liver Con't

- $\text{Synaptic_Liver_ACh}(t) = \text{Synaptic_Liver_ACh}(t - dt) + (\text{Natural_Production_of_Liver_ACh} - \text{Hydrolyzing_Liver_ACh}) * dt$
- $\text{INIT Synaptic_Liver_ACh} = 0.100$
- INFLOWS:
 - $\text{Natural_Production_of_Liver_ACh} = \text{Liver_ACh_Release_Rate}$
- OUTFLOWS:
 - $\text{Hydrolyzing_Liver_ACh} = \text{AChE_Hydrolysis_of_ACh} * \text{Conc_of_Liver_ACh} * \text{Conc_of_Liver_AChE} * \text{Liver_Vol}$
- $\text{Conc_of_Liver_ACh} = \text{Synaptic_Liver_ACh} / \text{Liver_Vol}$
- $\text{Liver_ACh_Homeostatic_State} = 0.100$
- $\text{Liver_ACh_Percentage} = (\text{Hundred_Percent} / \text{Liver_ACh_Homeostatic_State}) * \text{Synaptic_Liver_ACh}$
- $\text{Liver_ACh_Release_Rate} = 0.001237624$

Lung

- $\text{Exhaled}(t) = \text{Exhaled}(t - dt) + (\text{Exhale}) * dt$
- $\text{INIT Exhaled} = 0$
- INFLOWS:
 - $\text{Exhale} = \text{Conc_of_OP_Entering_AB} * \text{Pulmonary_Ventilation_Rate} / \text{Blood_Air_PC}$
- $\text{Conc_of_OP_Entering_AB} = (\text{Cardiac_Output} * \text{Conc_of_OP_Leaving_VB} + \text{Pulmonary_Ventilation_Rate} * \text{Post_Scrubbing_Air_Conc}) / (\text{Cardiac_Output} + \text{Pulmonary_Ventilation_Rate} / \text{Blood_Air_PC})$
- $\text{Post_Scrubbing_Air_Conc} = \text{Air_Conc} * (1 - \text{Scrubbing_Coeff})$

Mass Balance of OP in the System

- $\text{TOTAL_MASS}(t) = \text{TOTAL_MASS}(t - dt) + (\text{Intake}) * dt$
- $\text{INIT TOTAL_MASS} = 0$
- INFLOWS:
 - $\text{Intake} = \text{Air_Conc} * \text{Pulmonary_Ventilation_Rate}$

- $Distributed = OP_in_the_Brain + OP_in_Diaphragm + OP_in_Fat + OP_in_Kidney + OP_in_the_Liver + OP_in_RP + OP_in_SP + Exhaled + OP_in_Bronchial_Tissue + OP_in_Skin$
- $Distributed_Plus_Motabolism = Distributed + Motabolism$
- $Motabolism = Brain_OP_Lost_AChE + Brain_OP_Lost_BuChE + Brain_OP_Lost_CaE + Brain_OP_Lost_Metab + Liver_OP_Lost_AChE + Liver_Op_Lost_BuChE + Liver_OP_Lost_CaE + Liver_OP_Lost_Metab + Kidney_OP_Lost_BuChE + Kidney_OP_Lost_CaE + Kidney_OP_Lost_AChE + Kidney_OP_Lost_Metab + RP_OP_Lost_AChE + RP_OP_Lost_BuChE + RP_OP_Lost_CaE + RP_OP_Lost_Metab + SP_OP_Lost_AChE + SP_OP_Lost_BuChE + SP_OP_Lost_CaE + Diaphragm_OP_Lost_AChE + Diaphragm_OP_Lost_CaE + Diaphragm_BuChE + AB_OP_Lost_Enzymes + VB_OP_Lost_Enzymes + OP_in_AB + OP_in_VB$

Mich Men Cons

- $Brain_Km_of_OP = 440$
- $Brain_Vmax_of_OP = 1605.9$
- $Kidney_Km_of_OP = 134$
- $Kidney_Vmax_of_OP = 18070.9$
- $Liver_Km_of_OP = 50$
- $Liver_Vmax_of_OP = 1927.1$
- $RP_Km_of_OP = 50$
- $RP_Vmax_of_OP = 1933.1$

Other

- $AChE_Hydrolysis_of_ACh = 0.02$
- $BuChE_Inhibition_Rate = 0.4602$
- $CaE_Inhibition_Rate = 0.00143$
- $Delta_T = DT$
- $Hundred_Percent = 100$
- $Unit_Converter_mg_to_nmol = 1000000 / MW$
- $Unit_Converter_nmol_to_mg = MW / 1000000$

Partition Coeff

- $Blood_Air_PC = 15.57$
- $Brain_BPC_of_OP = 4.6$
- $Bronchial_BPC_of_OP = 5.2$
- $Diaphragm_BPC_of_OP = .5$
- $Fat_BPC_of_OP = 40$
- $Kidney_BPC_of_OP = 5.2$
- $Liver_BPC_of_OP = 5.2$

- $RP_BPC_of_OP = 5.2$
- $Skin_BPC_of_OP = .5$
- $SP_BPC_of_OP = .5$

Physical Parameters

- $Body_Weight = 60.6$
- $Cardiac_Flow = 14.5$
- $Pulmonary_Flow = 17$

Richly Perfused Con't

- $Synaptic_RP_ACh(t) = Synaptic_RP_ACh(t - dt) + (Natural_Production_of_RP_ACh - Hydrolyzing_RP_ACh) * dt$
- $INIT\ Synaptic_RP_ACh = 0.100$
- INFLOWS:
 - $Natural_Production_of_RP_ACh = RP_ACh_Release_Rate$
- OUTFLOWS:
 - $Hydrolyzing_RP_ACh = AChE_Hydrolysis_of_ACh * Conc_of_RP_ACh * Conc_of_RP_AChE * RP_Vol$
- $Conc_of_RP_ACh = Synaptic_RP_ACh / RP_Vol$
- $RP_ACh_Homeostatic_State = 0.100$
- $RP_ACh_Percentage = (Hundred_Percent / RP_ACh_Homeostatic_State) * Synaptic_RP_ACh$
- $RP_ACh_Release_Rate = .008005465$

Richly Perfused Tissues

- $Free_RP_AChE(t) = Free_RP_AChE(t - dt) + (Natural_Production_of_RP_AChE + Regeneration_of_RP_AChE - Inhibition_of_RP_AChE - Natural_Degradation_of_RP_AChE) * dt$
- $INIT\ Free_RP_AChE = 8.32$
- INFLOWS:
 - $Natural_Production_of_RP_AChE = RP_AChE_Synthesis_Rate$
 - $Regeneration_of_RP_AChE = AChE_Regeneration_Rate * Inhibited_RP_AChE$
- OUTFLOWS:
 - $Inhibition_of_RP_AChE = AChE_Inhibition_Rate * Conc_of_OP_in_RP * Conc_of_RP_AChE * Unit_Converter_mg_to_nmol * RP_Vol$
 - $Natural_Degradation_of_RP_AChE = RP_AChE_Degradation_Coeff * Free_RP_AChE$
- $Inhibited_RP_AChE(t) = Inhibited_RP_AChE(t - dt) + (Inhibition_of_RP_AChE - Regeneration_of_RP_AChE - Aged_RP_AChE) * dt$
- $INIT\ Inhibited_RP_AChE = 0$

- INFLOWS:
 - $\text{Inhibition_of_RP_AChE} = \text{AChE_Inhibition_Rate} * \text{Conc_of_OP_in_RP} * \text{Conc_of_RP_AChE} * \text{Unit_Converter_mg_to_nmol} * \text{RP_Vol}$
- OUTFLOWS:
 - $\text{Regeneration_of_RP_AChE} = \text{AChE_Regeneration_Rate} * \text{Inhibited_RP_AChE}$
 - $\text{Aged_RP_AChE} = \text{AChE_Aging_Rate} * \text{Inhibited_RP_AChE}$
- $\text{OP_in_RP}(t) = \text{OP_in_RP}(t - dt) + (\text{RP_AB_Flow_of_OP} - \text{RP_VB_Flow_of_OP} - \text{RP_Metabolism_of_OP} - \text{RP_OP_Lost_due_to_AChE} - \text{RP_OP_Lost_due_to_BuChE} - \text{RP_OP_Lost_due_to_CaE}) * dt$
- INIT $\text{OP_in_RP} = 0$
- INFLOWS:
 - $\text{RP_AB_Flow_of_OP} = \text{Cardiac_Output} * \text{RP_BFC} * \text{Conc_of_OP_Leaving_AB}$
- OUTFLOWS:
 - $\text{RP_VB_Flow_of_OP} = (\text{RP_BFC} * \text{Cardiac_Output}) * (\text{Conc_of_OP_in_RP} / \text{RP_BPC_of_OP})$
 - $\text{RP_Metabolism_of_OP} = (\text{RP_Vmax_of_OP} * (\text{Conc_of_OP_in_RP} / \text{RP_BPC_of_OP})) / (\text{RP_Km_of_OP} + (\text{Conc_of_OP_in_RP} / \text{RP_BPC_of_OP})) + \text{Kf_of_OP} * (\text{Conc_of_OP_in_RP} / \text{RP_BPC_of_OP}) * \text{RP_Vol}$
 - $\text{RP_OP_Lost_due_to_AChE} = \text{AChE_Inhibition_Rate} * \text{Conc_of_OP_in_RP} * \text{Conc_of_RP_AChE} * \text{RP_Vol}$
 - $\text{RP_OP_Lost_due_to_BuChE} = \text{BuChE_Inhibition_Rate} * \text{Conc_of_OP_in_RP} * \text{Conc_of_RP_BuChE} * \text{RP_Vol}$
 - $\text{RP_OP_Lost_due_to_CaE} = \text{CaE_Inhibition_Rate} * \text{Conc_of_OP_in_RP} * \text{Conc_of_RP_CaE} * \text{RP_Vol}$
- $\text{RP_BuChE}(t) = \text{RP_BuChE}(t - dt) + (\text{Synthesis_of_RP_BuChE} - \text{Inhibition_of_RP_BuChE} - \text{Degradation_of_RP_BuChE}) * dt$
- INIT $\text{RP_BuChE} = 205.92$
- INFLOWS:
 - $\text{Synthesis_of_RP_BuChE} = 205.92$
- OUTFLOWS:
 - $\text{Inhibition_of_RP_BuChE} = \text{BuChE_Inhibition_Rate} * \text{Conc_of_OP_in_RP} * \text{Conc_of_RP_BuChE} * \text{Unit_Converter_mg_to_nmol} * \text{RP_Vol}$
 - $\text{Degradation_of_RP_BuChE} = \text{RP_BuChE}$
- $\text{RP_CaE}(t) = \text{RP_CaE}(t - dt) + (\text{Synthesis_of_RP_CaE} - \text{Inhibition_of_RP_CaE} - \text{Degradation_of_RP_CaE}) * dt$
- INIT $\text{RP_CaE} = 443040$
- INFLOWS:
 - $\text{Synthesis_of_RP_CaE} = 88.608$
- OUTFLOWS:
 - $\text{Inhibition_of_RP_CaE} = \text{CaE_Inhibition_Rate} * \text{Conc_of_OP_in_RP} * \text{Conc_of_RP_CaE} * \text{Unit_Converter_mg_to_nmol} * \text{RP_Vol}$
 - $\text{Degradation_of_RP_CaE} = 0.0002 * \text{RP_CaE}$

- $RP_OP_Lost_AChE(t) = RP_OP_Lost_AChE(t - dt) + (RP_OP_Lost_due_to_AChE) * dt$
- $INIT RP_OP_Lost_AChE = 0$
- INFLOWS:
 - $RP_OP_Lost_due_to_AChE = AChE_Inhibition_Rate * Conc_of_OP_in_RP * Conc_of_RP_AChE * RP_Vol$
- $RP_OP_Lost_BuChE(t) = RP_OP_Lost_BuChE(t - dt) + (RP_OP_Lost_due_to_BuChE) * dt$
- $INIT RP_OP_Lost_BuChE = 0$
- INFLOWS:
 - $RP_OP_Lost_due_to_BuChE = BuChE_Inhibition_Rate * Conc_of_OP_in_RP * Conc_of_RP_BuChE * RP_Vol$
- $RP_OP_Lost_CaE(t) = RP_OP_Lost_CaE(t - dt) + (RP_OP_Lost_due_to_CaE) * dt$
- $INIT RP_OP_Lost_CaE = 0$
- INFLOWS:
 - $RP_OP_Lost_due_to_CaE = CaE_Inhibition_Rate * Conc_of_OP_in_RP * Conc_of_RP_CaE * RP_Vol$
- $RP_OP_Lost_Metab(t) = RP_OP_Lost_Metab(t - dt) + (RP_Metabolism_of_OP) * dt$
- $INIT RP_OP_Lost_Metab = 0$
- INFLOWS:
 - $RP_Metabolism_of_OP = (RP_Vmax_of_OP * (Conc_of_OP_in_RP / RP_BPC_of_OP)) / (RP_Km_of_OP + (Conc_of_OP_in_RP / RP_BPC_of_OP)) + Kf_of_OP * (Conc_of_OP_in_RP / RP_BPC_of_OP) * RP_Vol$
- $Conc_of_OP_in_RP = OP_in_RP / RP_Vol$
- $Conc_of_RP_AChE = Free_RP_AChE / RP_Vol$
- $Conc_of_RP_BuChE = RP_BuChE / RP_Vol$
- $Conc_of_RP_CaE = RP_CaE / RP_Vol$
- $RP_AChE_Degradation_Coeff = RP_AChE_Synthesis_Rate / RP_AChE_Homeostatic_State$
- $RP_AChE_Homeostatic_State = 8.32$
- $RP_AChE_Percentage = (Hundred_Percent / RP_AChE_Homeostatic_State) * Free_RP_AChE$
- $RP_AChE_Synthesis_Rate = 0.053$

Slowly Perfused Tissues

- $Free_SP_AChE(t) = Free_SP_AChE(t - dt) + (Natural_Production_of_SP_AChE + Regeneration_of_SP_AChE - Inhibition_of_SP_AChE - Natural_Degradation_of_SP_AChE) * dt$
- $INIT Free_SP_AChE = 233.87$
- INFLOWS:
 - $Natural_Production_of_SP_AChE = SP_AChE_Synthesis_Rate$

- $\text{Regeneration_of_SP_AChE} = \text{AChE_Regeneration_Rate} * \text{Inhibited_SP_AChE}$
- OUTFLOWS:
 - $\text{Inhibition_of_SP_AChE} = \text{AChE_Inhibition_Rate} * \text{Conc_of_OP_in_SP} * \text{Conc_of_SP_AChE} * \text{Unit_Converter_mg_to_nmol} * \text{SP_Vol}$
 - $\text{Natural_Degradation_of_SP_AChE} = \text{SP_AChE_Degradation_Coeff} * \text{Free_SP_AChE}$
- $\text{Inhibited_SP_AChE}(t) = \text{Inhibited_SP_AChE}(t - dt) + (\text{Inhibition_of_SP_AChE} - \text{Regeneration_of_SP_AChE} - \text{Aged_SP_AChE}) * dt$
- $\text{INIT Inhibited_SP_AChE} = 0$
- INFLOWS:
 - $\text{Inhibition_of_SP_AChE} = \text{AChE_Inhibition_Rate} * \text{Conc_of_OP_in_SP} * \text{Conc_of_SP_AChE} * \text{Unit_Converter_mg_to_nmol} * \text{SP_Vol}$
- OUTFLOWS:
 - $\text{Regeneration_of_SP_AChE} = \text{AChE_Regeneration_Rate} * \text{Inhibited_SP_AChE}$
 - $\text{Aged_SP_AChE} = \text{AChE_Aging_Rate} * \text{Inhibited_SP_AChE}$
- $\text{OP_in_SP}(t) = \text{OP_in_SP}(t - dt) + (\text{SP_Arterial_Blood_Flow_of_OP} - \text{SP_Venous_Blood_Flow_of_OP} - \text{SP_OP_Lost_due_to_AChE} - \text{SP_OP_Lost_due_to_CaE} - \text{SP_OP_Lost_due_to_BuChE}) * dt$
- $\text{INIT OP_in_SP} = 0$
- INFLOWS:
 - $\text{SP_Arterial_Blood_Flow_of_OP} = \text{Cardiac_Output} * \text{SP_BFC} * \text{Conc_of_OP_Leaving_AB}$
- OUTFLOWS:
 - $\text{SP_Venous_Blood_Flow_of_OP} = (\text{SP_BFC} * \text{Cardiac_Output}) * (\text{Conc_of_OP_in_SP} / \text{SP_BPC_of_OP})$
 - $\text{SP_OP_Lost_due_to_AChE} = \text{AChE_Inhibition_Rate} * \text{Conc_of_OP_in_SP} * \text{Conc_of_SP_AChE} * \text{SP_Vol}$
 - $\text{SP_OP_Lost_due_to_CaE} = \text{CaE_Inhibition_Rate} * \text{Conc_of_OP_in_SP} * \text{Conc_of_SP_CaE} * \text{SP_Vol}$
 - $\text{SP_OP_Lost_due_to_BuChE} = \text{BuChE_Inhibition_Rate} * \text{Conc_of_OP_in_SP} * \text{Conc_of_SP_BuChE} * \text{SP_Vol}$
- $\text{SP_CaE}(t) = \text{SP_CaE}(t - dt) + (\text{Synthesis_of_SP_CaE} - \text{Degradation_of_SP_CaE} - \text{Inhibition_of_SP_CaE}) * dt$
- $\text{INIT SP_CaE} = 76843$
- INFLOWS:
 - $\text{Synthesis_of_SP_CaE} = 76843$
- OUTFLOWS:
 - $\text{Degradation_of_SP_CaE} = \text{SP_CaE}$
 - $\text{Inhibition_of_SP_CaE} = \text{CaE_Inhibition_Rate} * \text{Conc_of_SP_CaE} * \text{Conc_of_OP_in_SP} * \text{Unit_Converter_mg_to_nmol} * \text{SP_Vol}$
- $\text{SP_OP_Lost_AChE}(t) = \text{SP_OP_Lost_AChE}(t - dt) + (\text{SP_OP_Lost_due_to_AChE}) * dt$

- $INIT\ SP_OP_Lost_AChE = 0$
- INFLOWS:
 - $SP_OP_Lost_due_to_AChE = AChE_Inhibition_Rate * Conc_of_OP_in_SP * Conc_of_SP_AChE * SP_Vol$
- $SP_OP_Lost_BuChE(t) = SP_OP_Lost_BuChE(t - dt) + (SP_OP_Lost_due_to_BuChE) * dt$
- $INIT\ SP_OP_Lost_BuChE = 0$
- INFLOWS:
 - $SP_OP_Lost_due_to_BuChE = BuChE_Inhibition_Rate * Conc_of_OP_in_SP * Conc_of_SP_BuChE * SP_Vol$
- $SP_OP_Lost_CaE(t) = SP_OP_Lost_CaE(t - dt) + (SP_OP_Lost_due_to_CaE) * dt$
- $INIT\ SP_OP_Lost_CaE = 0$
- INFLOWS:
 - $SP_OP_Lost_due_to_CaE = CaE_Inhibition_Rate * Conc_of_OP_in_SP * Conc_of_SP_CaE * SP_Vol$
- $SP_BuChE(t) = SP_BuChE(t - dt) + (Synthesis_of_SP_BuChE - Degradation_of_SP_BuChE - Inhibition_of_SP_BuChE) * dt$
- $INIT\ SP_BuChE = 200.46$
- INFLOWS:
 - $Synthesis_of_SP_BuChE = 200.46$
- OUTFLOWS:
 - $Degradation_of_SP_BuChE = SP_BuChE$
 - $Inhibition_of_SP_BuChE = BuChE_Inhibition_Rate * Conc_of_SP_BuChE * Conc_of_OP_in_SP * Unit_Converter_mg_to_nmol * SP_Vol$
- $Conc_of_OP_in_SP = OP_in_SP / SP_Vol$
- $Conc_of_SP_AChE = Free_SP_AChE / SP_Vol$
- $Conc_of_SP_BuChE = SP_BuChE / SP_Vol$
- $Conc_of_SP_CaE = SP_CaE / SP_Vol$
- $SP_AChE_Degradation_Coeff = SP_AChE_Synthesis_Rate / SP_AChE_Homeostatic_State$
- $SP_AChE_Percentage = (Hundred_Percent / SP_AChE_Homeostatic_State) * Free_SP_AChE$
- $SP_AChE_Synthesis_Rate = 0.053$
- $SP_AChE_Homeostatic_State = 233.87$

SP Con't

- $Synaptic_SP_ACh(t) = Synaptic_SP_ACh(t - dt) + (Natural_Production_of_SP_ACh - Hydrolyzing_SP_ACh) * dt$
- $INIT\ Synaptic_SP_ACh = 0.100$
- INFLOWS:
 - $Natural_Production_of_SP_ACh = SP_ACh_Release_Rate$

- OUTFLOWS:
 - $\text{Hydrolyzing_SP_ACh} = \text{AChE_Hydrolysis_of_ACh} * \text{Conc_of_SP_ACh} * \text{Conc_of_SP_AChE} * \text{SP_Vol}$
- $\text{Conc_of_SP_ACh} = \text{Synaptic_SP_ACh} / \text{SP_Vol}$
- $\text{SP_ACh_Homeostatic_State} = 0.100$
- $\text{SP_ACh_Percentage} = (\text{Hundred_Percent} / \text{SP_ACh_Homeostatic_State}) * \text{Synaptic_SP_ACh}$
- $\text{SP_ACh_Release_Rate} = 0.013998$

Tissue Volume

- $\text{AB_Vol} = \text{AB_VFC} * \text{Body_Weight}$
- $\text{Brain_Vol} = \text{Brain_VFC} * \text{Body_Weight}$
- $\text{Diaphragm_Vol} = \text{Body_Weight} * \text{Diaphragm_VFC}$
- $\text{Fat_Vol} = \text{Fat_VFC} * \text{Body_Weight}$
- $\text{Kidney_Vol} = \text{Kidney_VFC} * \text{Body_Weight}$
- $\text{Liver_Vol} = \text{Liver_VFC} * \text{Body_Weight}$
- $\text{Lung_Vol} = \text{Body_Weight} * \text{Lung_VFC}$
- $\text{RP_Vol} = \text{Richly_VFC} * \text{Body_Weight}$
- $\text{SP_Vol} = \text{Slowly_VFC} * \text{Body_Weight}$
- $\text{VB_Vol} = \text{Body_Weight} * \text{VB_VFC}$

Variable Patameters

- $\text{AChE_Aging_Rate} = .05$
- $\text{AChE_Inhibition_Rate} = .01$
- $\text{AChE_Regeneration_Rate} = .01$
- $\text{Air_Conc} = 1 + \text{STEP}(-1, 61)$
- $\text{Exposure_to_Skin} = 0.0 + \text{Step}(-0.0, 65)$
- $\text{Scrubbing_Coeff} = .5$
- $\text{Skin_Transfer_Coeff} = 0$
- $\text{Skin_Surface_Area} = 0$

Venous Blood Flow

- $\text{VB_OP_Lost_Enzymes}(t) = \text{VB_OP_Lost_Enzymes}(t - dt) + (\text{Inhibiting_in_VB}) * dt$
- $\text{INIT VB_OP_Lost_Enzymes} = 0$
- INFLOWS:
 - $\text{Inhibiting_in_VB} = ((\text{Amount_of_Conc_of_OP_Removed_after_Inhibition_by_BuChE_in_VB} + \text{Amount_of_Conc_of_OP_Removed_after_Inhibition_by_CaE_in_VB} + \text{Amount_of_Conc_of_OP_Removed_after_Inhibition_by_AChE_in_VB}) * \text{VB_Vol}) / \text{Delta_T}$

- $\text{Amount_of_Conc_of_OP_Removed_after_Inhibition_by_BuChE_in_VB} = \text{Unit_Converter_nmol_to_mg} * \text{VB_Inhibition_Rate_for_BuChE} * \text{Conc_of_VB_BuChE} * \text{Conc_of_OP_Entering_VB} * \text{Delta_T}$
- $\text{Amount_of_Conc_of_OP_Removed_after_Inhibition_by_CaE_in_VB} = \text{Unit_Converter_nmol_to_mg} * \text{VB_Inhibition_Rate_for_CaE} * \text{Conc_of_VB_CaE} * \text{Conc_of_OP_Entering_VB} * \text{Delta_T}$
- $\text{Amount_of_Conc_of_OP_Removed_after_Inhibition_by_AChE_in_VB} = \text{Unit_Converter_nmol_to_mg} * \text{VB_Inhibition_Rate_for_AChE} * \text{Conc_of_VB_AChE} * \text{Conc_of_OP_Entering_VB} * \text{Delta_T}$
- $\text{Conc_of_OP_Leaving_VB} = \text{Conc_of_OP_Entering_VB} - \text{Amount_of_Conc_of_OP_Removed_after_Inhibition_by_CaE_in_VB} - \text{Amount_of_Conc_of_OP_Removed_after_Inhibition_by_AChE_in_VB} - \text{Amount_of_Conc_of_OP_Removed_after_Inhibition_by_BuChE_in_VB}$
- $\text{Conc_of_OP_Entering_VB} = (\text{Brain_Venous_Blood_Flow_of_OP} + \text{Diaphragm_VB_Flow_of_OP} + \text{Fat_VB_Flow_of_OP} + \text{Kidney_VB_Flow_of_OP} + \text{Liver_VB_Flow_of_OP} + \text{RP_VB_Flow_of_OP} + \text{SP_Venous_Blood_Flow_of_OP} + \text{Bronchial_VB_Flow} + \text{Skin_VB_Flow_of_OP}) / \text{Cardiac_Output}$
- $\text{Conc_of_VB_CaE} = \text{Initial_Quantity_of_VB_CaE} / \text{VB_Vol}$
- $\text{Conc_of_VB_AChE} = \text{Initial_Quantity_of_VB_AChE} / \text{VB_Vol}$
- $\text{Conc_of_VB_BuChE} = \text{Initial_Quantity_of_VB_BuChE} / \text{VB_Vol}$
- $\text{Initial_Quantity_of_VB_AChE} = 3.85416$
- $\text{Initial_Quantity_of_VB_BuChE} = 19.2708$
- $\text{Initial_Quantity_of_VB_CaE} = 16187.47$
- $\text{OP_in_VB} = \text{Conc_of_OP_Leaving_VB} * \text{VB_Vol}$
- $\text{VB_Inhibition_Rate_for_BuChE} = .4248$
- $\text{VB_Inhibition_Rate_for_AChE} = 0.01416$
- $\text{VB_Inhibition_Rate_for_CaE} = 0.00108$

Volume Fraction Coeff

- $\text{AB_VFC} = 0.02$
- $\text{Brain_VFC} = 0.0214$
- $\text{Diaphragm_VFC} = 0.003$
- $\text{Fat_VFC} = 0.1700$
- $\text{Kidney_VFC} = 0.0043$
- $\text{Liver_VFC} = 0.04$
- $\text{Lung_VFC} = 0.0086$
- $\text{Richly_VFC} = 0.0343$
- $\text{Slowly_VFC} = 0.5514$
- $\text{VB_VFC} = 0.057$

Appendix 3 Model definition of terms

Parameters

Brain BFC	A coefficient that determines the blood flow to the brain
Liver BFC	A coefficient that determines the blood flow to the liver
Kidney BFC	A coefficient that determines the blood flow to the kidney
Fat BFC	A coefficient that determines the blood flow to the fat
SP BFC	A coefficient that determines the blood flow to the slowly perfused tissues
RP BFC	A coefficient that determines the blood flow to the rapidly perfused tissues
Diaphragm BFC	A coefficient that determines the blood flow to the diaphragm
Body weight	Body weight in kilograms
Pulmonary Flow	Normalized pulmonary flow
Cardiac Flow	Total blood flow throughout the body
Brain Vol	The volume of the brain in relation to the body
Liver Vol	The volume of the liver in relation to the body
Kidney Vol	The volume of the kidney in relation to the body
Fat Vol	The volume of the fat in relation to the body
SP Vol	The volume of the slowly perfused tissues in relation to the body

RP Vol	The volume of the rapidly perfused tissues in relation to the body
Diaphragm Vol	The volume of the diaphragm in relation to the body
Lung Vol	The volume of the lung in relation to the body
VB Vol	The volume of the venous blood in relation to the body
AB Vol	The volume of the arterial blood in relation to the body
MW	Molecular weight of OP to convert ppm by volume in air to mg/l air
Kf of OP	1 st order metabolic degradation coefficient normalized to body weight (this is controversial and I don't think this is a valid parameter; i.e. a 1 st order metabolic coefficient should be what it is and not scaled to body weight)
Brain VFC	A coefficient that scales the volume of the brain in relation to the body
Liver VFC	A coefficient that scales the volume of the brain in relation to the body
Kidney VFC	A coefficient that scales the volume of the brain in relation to the body
Fat VFC	A coefficient that scales the volume of the brain in relation to the body
Slowly VFC	A coefficient that scales the volume of the slowly perfused tissues in relation to the body
Richly VFC	A coefficient that scales the volume of the richly perfused tissues in relation to the body
Diaphragm VFC	A coefficient that scales the volume of the diaphragm in relation to the body

Lung VFC	A coefficient that scales the volume of the lung in relation to the body
VB VFC	A coefficient that scales the volume of the venous blood in relation to the body
AB VFC	A coefficient that scales the volume of the arterial blood in relation to the body
Blood Air PC	Blood/air partition coefficient
Brain BPC of OP	Brain/blood partition coefficient
Liver BPC of OP	Liver/blood partition coefficient
Kidney BPC of OP	Kidney/blood partition coefficient
Fat BPC of OP	Fat/blood partition coefficient
SP BPC of OP	Slowly perfused tissues/blood partition coefficient
RP BPC of OP	Rapidly perfused tissues/blood partition coefficient
Diaphragm BPC of OP	Diaphragm/blood partition coefficient
Bronchial BPC of OP	Bronchial/blood partition coefficient
Skin BPC of OP	Skin/blood partition coefficient
Brain Vmax of OP	Maximum metabolic rate in a saturable (or Michaelis-Menten) process for the brain
Liver Vmax of OP	Maximum metabolic rate in a saturable (or Michaelis-Menten) process for the liver
Kidney Vmax of OP	Maximum metabolic rate in a saturable (or Michaelis-Menten) process for the kidney
RP Vmax of OP	Maximum metabolic rate in a saturable (or Michaelis-Menten) process for the richly perfused tissues
Brain Km of OP	Half saturation constant for the brain (mg/l)

Liver Km of OP	Half saturation constant for the liver (mg/l)
Kidney Km of OP	Half saturation constant for the kidney (mg/l)
RP Km of OP	Half saturation constant for the richly perfused tissues (mg/l)
Cardiac Output	Total cardiac output (total systemic blood flow)
Pulmonary Ventilation Rate	Pulmonary ventilation rate
Air Conc	Chemical Concentration of the exterior breathing zone Air expressed as mg per liter of air
Exposure to Skin	Amount of organophosphate (in liquid form) that comes in contact with the skin
Scrubbing Coeff	Coefficient that determines how much of the organophosphate is scrubbed from the bronchial zone
Skin Transfer Coeff	Coefficient that determines how much of the organophosphate is allowed to penetrate the skin
Skin Surface Area	Amount of skin exposed to an organophosphate
AChE Inhibition Rate	Number that determines how fast the organophosphate inhibits AChE
AChE Aging Rate	Number that determines how fast the bonding between AChE and the organophosphate becomes a permanent bond
AChE Regeneration Rate	Number that determines how fast the bound between AChE and the organophosphate is broken and allows the AChE to become free AChE again
Hundred Percent	Represents 100%

Unit Converter mg to nmol	Converts mgs of OP to nmols of OP
Delta T	Change in time
AChE Hydrolysis of ACh	Coefficient that determines how fast AChE will break down the ACh via hydrolysis
Unit Converter nmol to mg	Converts nmols of OP to mgs of OP
Lung	
Conc of OP entering AB	Concentration of the OP after it has passed through the blood-gas exchange and entered the arterial blood flow
Exhale	Rate of OP being exhaled at a given time
Exhaled	total accumulated amount of OP exhaled from the body
Post scrubbing air conc	Amount (concentration) of OP entering the blood-gas exchange after scrubbing has taken place
Arterial Blood Flow	
AB inhibition rate for AChE	Coefficient that determines the rate at which the OP concentration can be reduced via binding with AChE
AB inhibition rate for BuChE	Coefficient that determines the rate at which the OP concentration can be reduced via binding with BuChE
AB inhibition rate for CaE	Coefficient that determines the rate at which the OP concentration can be reduced via binding with CaE
AB OP lost enzymes	Accumulation of OP removed from the arterial blood due to binding with AChE, BuChE and CaE over time
Amount of conc of OP removed after inhibition by AChE in AB	Amount the concentration of AChE is reduced due to binding with the OP

Amount of conc of OP removed after inhibition by BuChE in AB

Amount the concentration of BuChE is reduced due to binding with the OP

Amount of conc of OP removed after inhibition by CaE in AB

Amount the concentration of CaE is reduced due to binding with the OP

Inhibiting in AB

Rate at which OP is being removed from arterial blood due to binding with enzymes

Conc of AB AChE

Concentration of AChE in the brain at a given time

Conc of AB BuChE

Concentration of BuChE in the brain at a given time

Conc of AB CaE

Concentration of CaE in the brain at a given time

Conc of OP leaving AB

The concentration of OP being delivered to the body after AChE, BuChE and CaE have been reduced in concentration through binding with the OP

Initial quantity of AB AChE

homeostatic amount of AChE in the arterial blood

Initial quantity of AB BuChE

homeostatic amount of BuChE in the arterial blood

Initial quantity of AB CaE

homeostatic amount of CaE in the arterial blood

OP in AB

Amount of OP accumulated in the arterial blood

Brain

Aged Brain AChE

Amount of AChE becoming permanently bound with the OP

Brain ACh Percentage

Amount of ACh in the brain expressed as a percentage (100% equals homeostatic state)

Brain ACh Release Rate	The number used to determine the rate in which the ACh is released into the synaptic space
Brain AChE Degradation Coeff	The coefficient used to determine the rate in which the AChE is degraded by natural processes
Brain AChE Homeostatic State	The natural level of AChE in the brain
Brain AChE Percentage	Amount of AChE in the brain expressed as a percentage (100% equals homeostatic state)
Brain AChE Synthesis Rate	The number used to determine the rate in which the AChE is synthesized
Brain Arterial Blood Flow of OP	Amount of blood (carrying OP) flowing into the brain from the arterial blood system
Brain BuChE	Amount of unbound carboxyl esterase available in the brain
Brain CaE	Amount of unbound butyrylcholinesterase available in the brain
Brain ACh Homeostatic State	The natural level of ACh in the brain
Brain Metabolism of OP	Amount of OP being metabolized
Brain OP lost AChE	Accumulated amount of OP removed from tissue due to acetylcholinesterase
Brain OP lost due to AChE	Amount of OP being bound by acetylcholinesterase
Brain OP lost BuChE	Accumulated amount of OP removed from tissue due to butyrylcholinesterase
Brain OP lost due to BuChE	Amount of OP being bound by butyrylcholinesterase
Brain OP lost CaE	Accumulated amount of OP removed from tissue due to carboxyl esterase

Brain OP lost due to CaE	Amount of OP being bound by carboxyl esterase
Brain OP lost Metab	Accumulated amount of OP removed from tissue due to metabolism
Brain Venous Blood Flow of OP	Amount of blood leaving the brain (carrying OP) into the venous blood system
Conc of Brain ACh	Concentration of ACh in the brain at a given time
Conc of Brain AChE	Concentration of AChE in the brain at a given time
Conc of Brain BuChE	Concentration of butyrylcholinesterase in the brain at a given time
Conc of Brain CaE	Concentration of carboxyl esterase in the brain at a given time
Conc of OP in Brain	Concentration of OP in the brain at a given time
Degradation of Brain BuChE	Amount of butyrylcholinesterase being degraded by natural processes
Degradation of Brain CaE	Amount of carboxyl esterase being degraded by natural processes
Free brain AChE	Amount of unbound AChE available in the brain
Hydrolyzing brain ACh	Amount of ACh that binds with AChE resulting in the ACh being hydrolyzed
Inhibited Brain AChE	Amount of AChE that has been bound by an OP
Inhibition of Brain AChE	Amount of AChE being bound by OP in the brain
Inhibition of Brain BuChE	Amount of butyrylcholinesterase that has been bound by an OP

Inhibition of Brain CaE	Amount of carboxyl esterase that has been bound by an OP
Natural Production of Brain ACh	Amount of ACh released from the pre-synaptic side of the nerve cell in the brain
Natural Production of Brain AChE	Amount of AChE being synthesized into the brain
Natural Degradation of Brain AChE	Amount of AChE being degraded by natural processes
OP in the Brian	Amount of OP accumulated in the brain
Regeneration of Brain AChE	Amount of bound AChE becoming unbound and returning to free AChE
Synthesis of Brain CaE	Amount of carboxyl esterase being synthesized into the brain
Synthesis of Brain BuChE	Amount of butyrylcholinesterese being synthesized into the brain
Synaptic Brain ACh	Amount of unbound AChE available on the post-synaptic side of the nerve cell in the brain
Liver	
Aged Liver AChE	Amount of AChE becoming permanently bound with the OP
Liver ACh Percentage	Amount of ACh in the liver expressed as a percentage (100% equals homeostatic state)
Liver ACh Release Rate	The number used to determine the rate in which the ACh is released into the synaptic space
Liver AChE Degradation Coeff	The coefficient used to determine the rate in which the AChE is degraded by natural processes
Liver AChE Homeostatic State	The natural level of AChE in the liver

Liver AChE Percentage	Amount of AChE in the liver expressed as a percentage (100% equals homeostatic state)
Liver AChE Synthesis Rate	The number used to determine the rate in which the AChE is synthesized
Liver AB Flow of OP	Amount of blood (carrying OP) flowing into the liver from the arterial blood system
Liver BuChE	Amount of unbound carboxyl esterase available in the liver
Liver CaE	Amount of unbound butyrylcholinesterase available in the liver
Liver ACh Homeostatic State	The natural level of ACh in the liver
Liver Metabolism of OP	Amount of OP being metabolized
Liver OP lost AChE	Accumulated amount of OP removed from tissue due to acetylcholinesterase
Liver OP lost due to AChE	Amount of OP being bound by acetylcholinesterase
Liver OP lost BuChE	Accumulated amount of OP removed from tissue due to butyrylcholinesterase
Liver OP lost due to BuChE	Amount of OP being bound by butyrylcholinesterase
Liver OP lost CaE	Accumulated amount of OP removed from tissue due to carboxyl esterase
Liver OP lost due to CaE	Amount of OP being bound by carboxyl esterase
Liver OP lost Metab	Accumulated amount of OP removed from tissue due to metabolism
Liver VB Flow of OP	Amount of blood leaving the liver (carrying OP) into the venous blood system
Conc of Liver ACh	Concentration of ACh in the liver at a given time

Conc of Liver AChE	Concentration of AChE in the liver at a given time
Conc of Liver BuChE	Concentration of butyrylcholinesterase in the liver at a given time
Conc of Liver CaE	Concentration of carboxyl esterase in the liver at a given time
Conc of OP in Liver	Concentration of OP in the liver at a given time
Degradation of Liver BuChE	Amount of butyrylcholinesterase being degraded by natural processes
Degradation of Liver CaE	Amount of carboxyl esterase being degraded by natural processes
Free liver AChE	Amount of unbound AChE available in the liver
Hydrolyzing liver ACh	Amount of ACh that binds with AChE resulting in the ACh being hydrolyzed
Inhibited liver AChE	Amount of AChE that has been bound by an OP
Inhibition of liver AChE	Amount of AChE being bound by OP in the liver
Inhibition of liver BuChE	Amount of butyrylcholinesterase that has been bound by an OP
Inhibition of liver CaE	Amount of carboxyl esterase that has been bound by an OP
Natural Production of liver ACh	Amount of ACh released from the pre-synaptic side of the nerve cell in the liver
Natural Production of liver AChE	Amount of AChE being synthesized into the liver
Natural Degradation of liver AChE	Amount of AChE being degraded by natural processes

OP in liver	Amount of OP accumulated in the liver
Regeneration of liver AChE	Amount of bound AChE becoming unbound and returning to free AChE
Synthesis of liver CaE	Amount of carboxyl esterase being synthesized into the liver
Synthesis of liver BuChE	Amount of butyrylcholinesterase being synthesized into the liver
Synaptic liver ACh	Amount of unbound AChE available on the post-synaptic side of the nerve cell in the liver

Kidney

Aged kidney AChE	Amount of AChE becoming permanently bound with the OP
Kidney ACh Percentage	Amount of ACh in the kidney expressed as a percentage (100% equals homeostatic state)
Kidney ACh Release Rate	The number used to determine the rate in which the ACh is released into the synaptic space
Kidney AChE Degradation Coeff	The coefficient used to determine the rate in which the AChE is degraded by natural processes
Kidney AChE Homeostatic State	The natural level of AChE in the kidney
Kidney AChE Percentage	Amount of AChE in the liver expressed as a percentage (100% equals homeostatic state)
Kidney AChE Synthesis Rate	The number used to determine the rate in which the AChE is synthesized
Kidney AB Flow of OP	Amount of blood (carrying OP) flowing into the kidney from the arterial blood system
Kidney BuChE	Amount of unbound carboxyl esterase available in the kidney

Kidney CaE	Amount of unbound butyrylcholinesterese available in the kidney
Kidney ACh Homeostatic State	The natural level of ACh in the kidney
Kidney Metabolism of OP	Amount of OP being metabolized
Kidney OP lost AChE	Accumulated amount of OP removed from tissue due to acetylcholinesterase
Kidney OP lost due to AChE	Amount of OP being bound by acetylcholinesterase
Kidney OP lost BuChE	Accumulated amount of OP removed from tissue due to butyrylcholinesterese
Kidney OP lost due to BuChE	Amount of OP being bound by butyrylcholinesterese
Kidney OP lost CaE	Accumulated amount of OP removed from tissue due to carboxyl esterase
Kidney OP lost due to CaE	Amount of OP being bound by carboxyl esterase
Kidney OP lost Metab	Accumulated amount of OP removed from tissue due to metabolism
Kidney VB Flow of OP	Amount of blood leaving the kidney (carrying OP) into the venous blood system
Conc of kidney ACh	Concentration of ACh in the kidney at a given time
Conc of kidney AChE	Concentration of AChE in the kidney at a given time
Conc of kidney BuChE	Concentration of butyrylcholinesterese in the kidney at a given time
Conc of kidney CaE	Concentration of carboxyl esterase in the kidney at a given time
Conc of OP in kidney	Concentration of OP in the kidney at a given time

Degradation of kidney BuChE	Amount of butyrylcholinesterase being degraded by natural processes
Degradation of kidney CaE	Amount of carboxyl esterase being degraded by natural processes
Free kidney AChE	Amount of unbound AChE available in the kidney
Hydrolyzing kidney ACh	Amount of ACh that binds with AChE resulting in the ACh being hydrolyzed
Inhibited kidney AChE	Amount of AChE that has been bound by an OP
Inhibition of kidney AChE	Amount of AChE being bound by OP in the kidney
Inhibition of kidney BuChE	Amount of butyrylcholinesterase that has been bound by an OP
Inhibition of kidney CaE	Amount of carboxyl esterase that has been bound by an OP
Natural Production of kidney ACh	Amount of ACh released from the pre-synaptic side of the nerve cell in the kidney
Natural Production of kidney AChE	Amount of AChE being synthesized into the kidney
Natural Degradation of kidney AChE	Amount of AChE being degraded by natural processes
OP in kidney	Amount of OP accumulated in the kidney
Regeneration of kidney AChE	Amount of bound AChE becoming unbound and returning to free AChE
Synthesis of kidney CaE	Amount of carboxyl esterase being synthesized into the kidney
Synthesis of kidney BuChE	Amount of butyrylcholinesterase being synthesized into the kidney

Synaptic kidney ACh	Amount of unbound AChE available on the post-synaptic side of the nerve cell in the kidney
Richly Perfused Tissues	
Aged RP AChE	Amount of AChE becoming permanently bound with the OP
RP ACh Percentage	Amount of ACh in the RP expressed as a percentage (100% equals homeostatic state)
RP ACh Release Rate	The number used to determine the rate in which the ACh is released into the synaptic space
RP AChE Degradation Coeff	The coefficient used to determine the rate in which the AChE is degraded by natural processes
RP AChE Homeostatic State	The natural level of AChE in the RP
RP AChE Percentage	Amount of AChE in the liver expressed as a percentage (100% equals homeostatic state)
RP AChE Synthesis Rate	The number used to determine the rate in which the AChE is synthesized
RP AB Flow of OP	Amount of blood (carrying OP) flowing into the RP from the arterial blood system
RP BuChE	Amount of unbound carboxyl esterase available in the RP
RP CaE	Amount of unbound butyrylcholinesterase available in the RP
RP ACh Homeostatic State	The natural level of ACh in the RP
RP Metabolism of OP	Amount of OP being metabolized
RP OP lost AChE	Accumulated amount of OP removed from tissue due to acetylcholinesterase

RP OP lost due to AChE	Amount of OP being bound by acetylcholinesterase
RP OP lost BuChE	Accumulated amount of OP removed from tissue due to butyrylcholinesterase
RP OP lost due to BuChE	Amount of OP being bound by butyrylcholinesterase
RP OP lost CaE	Accumulated amount of OP removed from tissue due to carboxyl esterase
RP OP lost due to CaE	Amount of OP being bound by carboxyl esterase
RP OP lost Metab	Accumulated amount of OP removed from tissue due to metabolism
RP VB Flow of OP	Amount of blood leaving the RP (carrying OP) into the venous blood system
Conc of RP ACh	Concentration of ACh in the RP at a given time
Conc of RP AChE	Concentration of AChE in the RP at a given time
Conc of RP BuChE	Concentration of butyrylcholinesterase in the RP at a given time
Conc of RP CaE	Concentration of carboxyl esterase in the RP at a given time
Conc of OP in RP	Concentration of OP in the RP at a given time
Degradation of RP BuChE	Amount of butyrylcholinesterase being degraded by natural processes
Degradation of RP CaE	Amount of carboxyl esterase being degraded by natural processes
Free RP AChE	Amount of unbound AChE available in the RP
Hydrolyzing RP ACh	Amount of ACh that binds with AChE resulting in the ACh being hydrolyzed

Inhibited RP AChE	Amount of AChE that has been bound by an OP
Inhibition of RP AChE	Amount of AChE being bound by OP in the RP
Inhibition of RP BuChE	Amount of butyrylcholinesterase that has been bound by an OP
Inhibition of RP CaE	Amount of carboxyl esterase that has been bound by an OP
Natural Production of RP ACh	Amount of ACh released from the pre-synaptic side of the nerve cell in the RP
Natural Production of RP AChE	Amount of AChE being synthesized into the RP
Natural Degradation of RP AChE	Amount of AChE being degraded by natural processes
OP in RP	Amount of OP accumulated in the RP
Regeneration of RP AChE	Amount of bound AChE becoming unbound and returning to free AChE
Synthesis of RP CaE	Amount of carboxyl esterase being synthesized into the RP
Synthesis of RP BuChE	Amount of butyrylcholinesterase being synthesized into the RP
Synaptic RP ACh	Amount of unbound AChE available on the post-synaptic side of the nerve cell in the RP
Fat	
OP in Fat	Amount of OP accumulated in the fat
Fat AB flow of OP	Amount of blood (carrying OP) flowing into fat from the arterial blood system
Fat VB flow of OP	Amount of blood leaving fat (carrying OP) into the venous blood system

Conc of OP in fat tissue	Concentration of OP in fat at a given time
Slowly Perfused Tissues	
Aged SP AChE	Amount of AChE becoming permanently bound with the OP
SP ACh Percentage	Amount of ACh in the SP expressed as a percentage (100% equals homeostatic state)
SP ACh Release Rate	The number used to determine the rate in which the ACh is released into the synaptic space
SP AChE Degradation Coeff	The coefficient used to determine the rate in which the AChE is degraded by natural processes
SP AChE Homeostatic State	The natural level of AChE in the SP
SP AChE Percentage	Amount of AChE in the liver expressed as a percentage (100% equals homeostatic state)
SP AChE Synthesis Rate	The number used to determine the rate in which the AChE is synthesized
SP Arterial Blood Flow of OP	Amount of blood (carrying OP) flowing into the SP from the arterial blood system
SP BuChE	Amount of unbound carboxyl esterase available in the SP
SP CaE	Amount of unbound butyrylcholinesterase available in the SP
SP ACh Homeostatic State	The natural level of ACh in the SP
SP OP lost AChE	Accumulated amount of OP removed from tissue due to acetylcholinesterase
SP OP lost due to AChE	Amount of OP being bound by acetylcholinesterase

SP OP lost BuChE	Accumulated amount of OP removed from tissue due to butyrylcholinesterase
SP OP lost due to BuChE	Amount of OP being bound by butyrylcholinesterase
SP OP lost CaE	Accumulated amount of OP removed from tissue due to carboxyl esterase
SP OP lost due to CaE	Amount of OP being bound by carboxyl esterase
SP Venous Blood Flow of OP	Amount of blood leaving the SP (carrying OP) into the venous blood system
Conc of SP ACh	Concentration of ACh in the SP at a given time
Conc of SP AChE	Concentration of AChE in the SP at a given time
Conc of SP BuChE	Concentration of butyrylcholinesterase in the SP at a given time
Conc of SP CaE	Concentration of carboxyl esterase in the SP at a given time
Conc of OP in SP	Concentration of OP in the SP at a given time
Degradation of SP BuChE	Amount of butyrylcholinesterase being degraded by natural processes
Degradation of SP CaE	Amount of carboxyl esterase being degraded by natural processes
Free SP AChE	Amount of unbound AChE available in the SP
Hydrolyzing SP ACh	Amount of ACh that binds with AChE resulting in the ACh being hydrolyzed
Inhibited SP AChE	Amount of AChE that has been bound by an OP
Inhibition of SP AChE	Amount of AChE being bound by OP in the SP

Inhibition of SP BuChE	Amount of butyrylcholinesterase that has been bound by an OP
Inhibition of SP CaE	Amount of carboxyl esterase that has been bound by an OP
Natural Production of SP ACh	Amount of ACh released from the pre-synaptic side of the nerve cell in the SP
Natural Production of SP AChE	Amount of AChE being synthesized into the SP
Natural Degradation of SP AChE	Amount of AChE being degraded by natural processes
OP in SP	Amount of OP accumulated in the SP
Regeneration of SP AChE	Amount of bound AChE becoming unbound and returning to free AChE
Synthesis of SP CaE	Amount of carboxyl esterase being synthesized into the SP
Synthesis of SP BuChE	Amount of butyrylcholinesterase being synthesized into the SP
Synaptic SP ACh	Amount of unbound AChE available on the post-synaptic side of the nerve cell in the SP

Diaphragm

Aged Diaphragm AChE	Amount of AChE becoming permanently bound with the OP
Diaphragm ACh Percentage	Amount of ACh in the diaphragm expressed as a percentage (100% equals homeostatic state)
Diaphragm ACh Release Rate	The number used to determine the rate in which the ACh is released into the synaptic space

Diaphragm AChE Degradation Coeff	The coefficient used to determine the rate in which the AChE is degraded by natural processes
Diaphragm AChE Homeostatic State	The natural level of AChE in the diaphragm
Diaphragm AChE Percentage	Amount of AChE in the diaphragm expressed as a percentage (100% equals homeostatic state)
Diaphragm AChE Synthesis Rate	The number used to determine the rate in which the AChE is synthesized
Diaphragm AB Flow of OP	Amount of blood (carrying OP) flowing into the diaphragm from the arterial blood system
Diaphragm BuChE	Amount of unbound carboxyl esterase available in the diaphragm
Diaphragm CaE	Amount of unbound butyrylcholinesterase available in the diaphragm
Diaphragm ACh Homeostatic State	The natural level of ACh in the diaphragm
Diaphragm OP lost AChE	Accumulated amount of OP removed from tissue due to acetylcholinesterase
Diaphragm OP lost due to AChE	Amount of OP being bound by acetylcholinesterase
Diaphragm OP lost BuChE	Accumulated amount of OP removed from tissue due to butyrylcholinesterase
Diaphragm OP lost due to BuChE	Amount of OP being bound by butyrylcholinesterase
Diaphragm OP lost CaE	Accumulated amount of OP removed from tissue due to carboxyl esterase
Diaphragm OP lost due to CaE	Amount of OP being bound by carboxyl esterase
Diaphragm VB Flow of OP	Amount of blood leaving the diaphragm (carrying OP) into the venous blood system

Conc of Diaphragm ACh	Concentration of ACh in the diaphragm at a given time
Conc of Diaphragm AChE	Concentration of AChE in the diaphragm at a given time
Conc of Diaphragm BuChE	Concentration of butyrylcholinesterase in the diaphragm at a given time
Conc of Diaphragm CaE	Concentration of carboxyl esterase in the diaphragm at a given time
Conc of OP in Diaphragm	Concentration of OP in the diaphragm at a given time
Degradation of Diaphragm BuChE	Amount of butyrylcholinesterase being degraded by natural processes
Degradation of Diaphragm CaE	Amount of carboxyl esterase being degraded by natural processes
Free Diaphragm AChE	Amount of unbound AChE available in the diaphragm
Hydrolyzing Diaphragm ACh	Amount of ACh that binds with AChE resulting in the ACh being hydrolyzed
Inhibited Diaphragm AChE	Amount of AChE that has been bound by an OP
Inhibition of Diaphragm AChE	Amount of AChE being bound by OP in the diaphragm
Inhibition of Diaphragm BuChE	Amount of butyrylcholinesterase that has been bound by an OP
Inhibition of Diaphragm CaE	Amount of carboxyl esterase that has been bound by an OP
Natural Production of Diaphragm ACh	Amount of ACh released from the pre-synaptic side of the nerve cell in the diaphragm
Natural Production of Diaphragm AChE	Amount of AChE being synthesized into the diaphragm

Natural Degradation of Diaphragm AChE	Amount of AChE being degraded by natural processes
OP in Diaphragm	Amount of OP accumulated in the diaphragm
Regeneration of Diaphragm AChE	Amount of bound AChE becoming unbound and returning to free AChE
Synthesis of Diaphragm CaE	Amount of carboxyl esterase being synthesized into the diaphragm
Synthesis of Diaphragm BuChE	Amount of butyrylcholinesterase being synthesized into the diaphragm
Synaptic Diaphragm ACh	Amount of unbound AChE available on the post-synaptic side of the nerve cell in the diaphragm

Venous Blood Flow

Amount of Conc of OP removed after inhibition by AChE in VB	Amount the concentration of AChE is reduced due to binding with the OP
Amount of Conc of OP removed after inhibition by BuChE in VB	Amount the concentration of BuChE is reduced due to binding with the OP
Amount of Conc of OP removed after inhibition by CaE in VB	Amount the concentration of CaE is reduced due to binding with the OP
Conc of OP entering VB	summation of OP concentrations leaving
Conc of OP leaving VB	The concentration of OP being returned from the body after AChE, BuChE and CaE have been reduced in concentration through binding with the OP
Conc of VB AChE	Concentration of AChE in the brain at a given time
Conc of VB BuChE	Concentration of BuChE in the brain at a given time
Conc of VB CaE	Concentration of CaE in the brain at a given time

Inhibiting in VB	Rate at which OP is being removed from venous blood due to binding with enzymes
Initial quantity of VB AChE	homeostatic amount of AChE in the venous blood
Initial quantity of VB BuChE	homeostatic amount of BuChE in the venous blood
Initial quantity of VB CaE	homeostatic amount of CaE in the venous blood
OP in VB	Amount of OP accumulated in the venous blood
VB inhibition rate for AChE	Coefficient that determines the rate at which the OP concentration can be reduced via binding with AChE
VB inhibition rate for BuChE	Coefficient that determines the rate at which the OP concentration can be reduced via binding with BuChE
VB inhibition rate for CaE	Coefficient that determines the rate at which the OP concentration can be reduced via binding with CaE
VB OP lost enzymes	Accumulation of OP removed from the venous blood due to binding with AChE, BuChE and CaE over time

Bronchial

OP in bronchial tissue	Amount of OP accumulated in the bronchial tissue
Bronchial AB flow	Amount of blood (carrying OP) flowing into the bronchial tissue from the arterial blood system
Bronchial VB flow	Amount of blood leaving the bronchial tissue (carrying OP) into the venous blood system

Bronchial intake	Amount of OP being delivered to the bronchial tissues via the air way/breathing zone by inhaling
Bronchial BFC	A coefficient that determines the blood flow to the bronchial tissue
Bronchial Vol	The volume of the bronchial tissue in relation to the body
Conc of OP in Bronchial	Concentration of OP in the bronchial tissue at a given time

Dermal

OP in the skin	Amount of OP accumulated in the skin
Absorption of OP via skin	Rate at which an OP is entering the body via the skin
Skin VB flow of OP	Amount of blood leaving the skin (carrying OP) into the venous blood system
Skin AB flow of OP	Amount of blood (carrying OP) flowing into the skin from the arterial blood system
Skin BFC	A coefficient that determines the blood flow to the skin
Vol of skin	The volume of the skin in relation to the body
Conc of OP in skin	Concentration of OP in the skin at a given time
Skin VFC	A coefficient that scales the volume of the skin in relation to the body

Appendix 4 Model differential equations

Equations for the amount of OP in a given tissue group.

$$V_{Br} \times \frac{dC_{Br}}{dt} = Q_{Br} \times (C_{ABr} - C_{VBr}) - \frac{V_{\max Br} \times C_{VBr}}{K_{mBr} + C_{VBr}} - K_{AChE} \times C_{Br} \times C_{AChEBr} - K_{CaE} \times C_{Br} \times C_{CaEBr} - K_{BuChE} \times C_{Br} \times C_{BuChEBr}$$

$$V_{Lr} \times \frac{dC_{Lr}}{dt} = Q_{Lr} \times (C_{ALr} - C_{VLr}) - \frac{V_{\max Lr} \times C_{VLr}}{K_{mLr} + C_{VLr}} - K_{AChE} \times C_{Lr} \times C_{AChELr} - K_{CaE} \times C_{Lr} \times C_{CaELr} - K_{BuChE} \times C_{Lr} \times C_{BuChELr}$$

$$V_{Kd} \times \frac{dC_{Kd}}{dt} = Q_{Kd} \times (C_{AKd} - C_{VKd}) - \frac{V_{\max Kd} \times C_{VKd}}{K_{mKd} + C_{VKd}} - K_{AChE} \times C_{Kd} \times C_{AChEKd} - K_{CaE} \times C_{Kd} \times C_{CaEKd} - K_{BuChE} \times C_{Kd} \times C_{BuChEKd}$$

$$V_{RP} \times \frac{dC_{RP}}{dt} = Q_{RP} \times (C_{ARP} - C_{VRP}) - \frac{V_{\max RP} \times C_{VRP}}{K_{mRP} + C_{VRP}} - K_{AChE} \times C_{RP} \times C_{AChERP} - K_{CaE} \times C_{RP} \times C_{CaERP} - K_{BuChE} \times C_{RP} \times C_{BuChERP}$$

$$V_{SP} \times \frac{dC_{SP}}{dt} = Q_{SP} \times (C_{ASP} - C_{VSP}) - K_{AChE} \times C_{SP} \times C_{AChESP} - K_{CaE} \times C_{SP} \times C_{CaESP} - K_{BuChE} \times C_{SP} \times C_{BuChESP}$$

$$V_{Dp} \times \frac{dC_{Dp}}{dt} = Q_{Dp} \times (C_{ADp} - C_{VDp}) - K_{AChE} \times C_{Dp} \times C_{AChEDp} - K_{CaE} \times C_{Dp} \times C_{CaEDp} - K_{BuChE} \times C_{Dp} \times C_{BuChEDp}$$

$$V_{BS} \times \frac{dC_{BS}}{dt} = Q_{BS} \times (C_{ABS} - C_{VBS}) + P_{VR} \times Air_{Conc} \times S_C$$

$$V_{Sk} \times \frac{dC_{Sk}}{dt} = Q_{Sk} \times (C_{ASk} - C_{VSk}) + S_{TC} + S_{SA} + OP$$

Legend:

V_{Br} = Volume of brain (liters)

V_{Lr} = Volume of liver (liters)

V_{Kd} = Volume of kidney (liters)

V_{RP} = Volume of richly perfused tissues (liters)

V_{SP} = Volume of slowly perfused tissues (liters)

V_{Dp} = Volume of diaphragm (liters)

V_{BS} = Volume of bronchial tissue (liters)

V_{Sk} = Volume of skin (liters)

Q_{Br} = Cardiac Output to the brain (liters per hour)

Q_{Lr} = Cardiac Output to the liver (liters per hour)

Q_{Kd} = Cardiac Output to the kidney (liters per hour)

Q_{RP} = Cardiac Output to the richly perfused tissues (liters per hour)

Q_{SP} = Cardiac Output to the slowly perfused tissues (liters per hour)

Q_{Dp} = Cardiac Output to the diaphragm (liters per hour)

Q_{BS} = Cardiac Output to the bronchial tissue (liters per hour)

Q_{Sk} = Cardiac Output to the skin (liters per hour)

C_{ABr} = Concentration of OP in the arterial brain (mg per liter)

C_{ALr} = Concentration of OP in the arterial liver (mg per liter)

C_{AKd} = Concentration of OP in the arterial kidney (mg per liter)

C_{ARP} = Concentration of OP in the arterial richly perfused tissues (mg per liter)

C_{ASP} = Concentration of OP in the arterial slowly perfused tissues (mg per liter)

C_{ADp} = Concentration of OP in the arterial diaphragm (mg per liter)

C_{ABS} = Concentration of OP in the arterial bronchial tissue (mg per liter)

C_{ASk} = Concentration of OP in the arterial skin (mg per liter)

C_{VBr} = Concentration of OP in the venous brain (mg per liter)

C_{VLr} = Concentration of OP in the venous liver (mg per liter)

C_{VKd} = Concentration of OP in the venous kidney (mg per liter)

C_{VRP} = Concentration of OP in the venous richly perfused tissues (mg per liter)

C_{VSP} = Concentration of OP in the venous slowly perfused tissues (mg per liter)

C_{VDp} = Concentration of OP in the venous diaphragm (mg per liter)
 C_{VBS} = Concentration of OP in the venous bronchial tissue (mg per liter)
 C_{VSk} = Concentration of OP in the venous skin (mg per liter)
 V_{maxBr} = Maximum rate of OP hydrolysis in brain (mg per hour)
 V_{maxLr} = Maximum rate of OP hydrolysis in liver (mg per hour)
 V_{maxKd} = Maximum rate of OP hydrolysis in kidney (mg per hour)
 V_{maxRP} = Maximum rate of OP hydrolysis in richly perfused tissues (mg per hour)
 K_{mBr} = Michaelis-Menten constant for OP in brain (mg per liter)
 K_{mLr} = Michaelis-Menten constant for OP hydrolysis in liver (mg per hour)
 K_{mKd} = Michaelis-Menten constant for OP hydrolysis in kidney (mg per hour)
 K_{mRP} = Michaelis-Menten constant for OP hydrolysis in richly perfused tissues (mg per hour)
 K_{AChE} = Bimolecular rate constant for OP reaction with AChE (nM-hr)⁻¹
 K_{CaE} = Bimolecular rate constant for OP reaction with CaE (nM-hr)⁻¹
 K_{BuChE} = Bimolecular rate constant for OP reaction with BuChE (nM-hr)⁻¹
 C_{Br} = Concentration of OP in the brain compartment (mg per liter)
 C_{Lr} = Concentration of OP in the liver compartment (mg per liter)
 C_{Kd} = Concentration of OP in the kidney compartment (mg per liter)
 C_{RP} = Concentration of OP in the richly perfused compartment (mg per liter)
 C_{SP} = Concentration of OP in the slowly perfused compartment (mg per liter)
 C_{Dp} = Concentration of OP in the diaphragm compartment (mg per liter)
 C_{AChEBr} = AChE concentration in the brain (nmol per liter)
 C_{AChELr} = AChE concentration in the liver (nmol per liter)

C_{AChEKd} = AChE concentration in the kidney (nmol per liter)

C_{AChERP} = AChE concentration in the richly perfused tissues (nmol per liter)

C_{AChESP} = AChE concentration in the slowly perfused tissues (nmol per liter)

C_{AChEDp} = AChE concentration in the diaphragm (nmol per liter)

C_{CaEBr} = CaE concentration in the brain (nmol per liter)

C_{CaELr} = CaE concentration in the liver (nmol per liter)

C_{CaEKd} = CaE concentration in the kidney (nmol per liter)

C_{CaERP} = CaE concentration in the richly perfused tissues (nmol per liter)

C_{CaESP} = CaE concentration in the slowly perfused tissues (nmol per liter)

C_{CaEDp} = CaE concentration in the diaphragm (nmol per liter)

$C_{BuChEBr}$ = BuChE concentration in the brain (nmol per liter)

$C_{BuChELr}$ = BuChE concentration in the liver (nmol per liter)

$C_{BuChEKd}$ = BuChE concentration in the kidney (nmol per liter)

$C_{BuChERP}$ = BuChE concentration in the richly perfused tissues (nmol per liter)

$C_{BuChESP}$ = BuChE concentration in the slowly perfused tissues (nmol per liter)

$C_{BuChEDp}$ = BuChE concentration in the diaphragm (nmol per liter)

P_{VR} = Pulmonary ventilation rate (liters per hour)

Air_{Conc} = Chemical concentration of the external breathing area of the exterior breathing zone (mg per liter of air)

S_C = Bronchial scrubbing coefficient (unitless)

S_{TC} = Skin transfer coefficient (cm^2 -hr)⁻¹

S_{SA} = Skin surface area (cm^2)

OP = Exposure to the skin (mg)

Equations to calculate inhibited AChE activity in the different tissue groups.

$$V_{Br} \times \frac{dC_{AChEBr}}{dt} = K_{AChE} \times C_{AChEBr} \times C_{Br} \times V_{Br} \times conversion - KR_{AChE} \times AChE_{Br} - KA_{AChE} \times AChE_{Br}$$

$$V_{Lr} \times \frac{dC_{AChELr}}{dt} = K_{AChE} \times C_{AChELr} \times C_{Lr} \times V_{Lr} \times conversion - KR_{AChE} \times AChE_{Lr} - KA_{AChE} \times AChE_{Lr}$$

$$V_{Kd} \times \frac{dC_{AChEKd}}{dt} = K_{AChE} \times C_{AChEKd} \times C_{Kd} \times V_{Kd} \times conversion - KR_{AChE} \times AChE_{Kd} - KA_{AChE} \times AChE_{Kd}$$

$$V_{RP} \times \frac{dC_{AChERP}}{dt} = K_{AChE} \times C_{AChERP} \times C_{RP} \times V_{RP} \times conversion - KR_{AChE} \times AChE_{RP} - KA_{AChE} \times AChE_{RP}$$

$$V_{SP} \times \frac{dC_{AChESP}}{dt} = K_{AChE} \times C_{AChESP} \times C_{SP} \times V_{SP} \times conversion - KR_{AChE} \times AChE_{SP} - KA_{AChE} \times AChE_{SP}$$

$$V_{Dp} \times \frac{dC_{AChEDp}}{dt} = K_{AChE} \times C_{AChEDp} \times C_{Dp} \times V_{Dp} \times conversion - KR_{AChE} \times AChE_{Dp} - KA_{AChE} \times AChE_{Dp}$$

Legend:

K_{AChE} = Bimolecular rate constant for OP reaction with AChE (nM-hr)⁻¹

C_{AChEBr} = Concentration of free AChE in the brain (nM)

C_{AChELr} = Concentration of free AChE in the liver (nM)

C_{AChEKd} = Concentration of free AChE in the kidney (nM)

C_{AChERP} = Concentration of free AChE in the richly perfused tissues (nM)

C_{AChESP} = Concentration of free AChE in the slowly perfused tissues (nM)

C_{AChEDp} = Concentration of free AChE in the diaphragm (nM)

Conversion = Changes units from mg per liter to nmol per liter

KR_{AChE} = Rate of regeneration of inhibited AChE (hr⁻¹)

KA_{AChE} = Rate of aging of inhibited AChE (hr⁻¹)

$AChE_{Br}$ = Inhibited AChE in the brain (nM)

$AChE_{Lr}$ = Inhibited AChE in the liver (nM)

$AChE_{Kd}$ = Inhibited AChE in the kidney (nM)

$AChE_{RP}$ = Inhibited AChE in the richly perfused tissues (nM)

$AChE_{SP}$ = Inhibited AChE in the slowly perfused tissues (nM)

$AChE_{Dp}$ = Inhibited AChE in the diaphragm (nM)

Equations to calculate the amount of ACh activity in the different tissue groups.

$$V_{Br} \times \frac{dC_{AChBr}}{dt} = ACh_{RR} - ACh_{Hyd} \times C_{AChEBr} \times C_{AChBr} \times V_{Br}$$

$$V_{Lr} \times \frac{dC_{AChLr}}{dt} = ACh_{RR} - ACh_{Hyd} \times C_{AChELr} \times C_{AChLr} \times V_{Lr}$$

$$V_{Kd} \times \frac{dC_{AChKd}}{dt} = ACh_{RR} - ACh_{Hyd} \times C_{AChEKd} \times C_{AChKd} \times V_{Kd}$$

$$V_{RP} \times \frac{dC_{AChRP}}{dt} = ACh_{RR} - ACh_{Hyd} \times C_{AChERP} \times C_{AChRP} \times V_{RP}$$

$$V_{SP} \times \frac{dC_{AChSP}}{dt} = ACh_{RR} - ACh_{Hyd} \times C_{AChESP} \times C_{AChSP} \times V_{SP}$$

$$V_{Dp} \times \frac{dC_{AChDp}}{dt} = ACh_{RR} - ACh_{Hyd} \times C_{AChEDp} \times C_{AChDp} \times V_{Dp}$$

Legend:

ACh_{RR} = ACh release rate from presynaptic side (nM per hour)

ACh_{Hyd} = AChE hydrolysis of ACh coefficient (nM-hr)⁻¹

C_{AChBr} = Concentration of ACh in the brain (nM)

CACHLr = Concentration of ACh in the liver (nM)

CACHKd = Concentration of ACh in the kidney (nM)

CACHRP = Concentration of ACh in the richly perfused tissues (nM)

CACHSP = Concentration of ACh in the slowly perfused tissues (nM)

CACHDp = Concentration of ACh in the diaphragm (nM)

Appendix 5 Model parameters for each trial

Partition Coefficients									
Trial	1	2	3	4	5	6	7	8	9
Air	3.57	6.57	9.57	12.57	15.57	18.57	21.57	24.57	27.57
Brain	0.61	1.01	1.41	1.81	4.60	10.54	15.54	20.54	25.54
Liver	0.57	1.07	1.57	2.07	5.20	12.04	18.04	24.04	30.04
Kidney	0.57	1.07	1.57	2.07	5.20	12.04	18.04	24.04	30.04
RP	0.57	1.07	1.57	2.07	5.20	12.04	18.04	24.04	30.04
Fat	0.88	5.88	10.88	15.88	40.00	92.43	132.43	172.43	212.43
SP	0.11	0.14	0.17	0.20	0.50	1.16	1.56	1.96	2.36
Diaphragm	0.11	0.14	0.17	0.20	0.50	1.16	1.56	1.96	2.36
Bronchial'	0.57	1.07	1.57	2.07	5.20	12.04	18.04	24.04	30.04
Skin'	0.11	0.14	0.17	0.20	0.50	1.16	1.56	1.96	2.36
Metabolism									
Trial	1	2	3	4	5	6	7	8	9
Brain	337.50	65.35	437.50	75.35	537.50	85.35	637.50	95.35	1,605.90
Liver	465.40	4.86	565.40	6.86	665.40	8.86	765.40	10.86	1,927.10
Kidney	4,173.83	14.12	5,173.83	19.12	6,173.83	24.12	7,173.83	29.12	18,070.90
RP	466.60	5.03	566.60	7.03	666.60	9.03	766.60	11.03	1,933.10
Trial	6	7	8	9					
Brain	3,711.14	1,622.77	4,711.14	2,622.77					
Liver	4,452.89	184.82	5,952.89	284.82					
Kidney	41,755.22	495.54	51,755.22	695.54					
RP	4,463.19	187.77	5,963.19	287.77					

Inhibition Coeff									
Trial	1	2	3	4	5	6	7	8	9
All Tissues	0.00097	0.00197	0.00297	0.00397	0.01	0.02311	0.03311	0.04311	0.05311
Aging Rate									
Trial	1	2	3	4	5	6	7	8	9
All Tissues	0.008	0.009	0.01	0.02	0.05	0.12	0.17	0.22	0.27
Regeneration Rate									
Trial	1	2	3	4	5	6	7	8	9
All Tissues	0.001	0.002	0.003	0.004	0.01	0.02	0.03	0.04	0.05

Appendix 6 Simulations run for sensitivity analysis

Inhalation

There will only be five different trials for this section in order to reduce the amount of simulations run. The values for each trial will correspond to trials 1, 3, 5, 7, and 9.

During this section of the analysis there will be 100 simulations conducted.

Note: The numbers shown in the matrix are equal to the values for that trial when only one parameter was being changed at the time. For example, for trial 1 the partition coeff = 0.68 for air, -3.26 for brain, etc and the aging rate = 0.05.

Partition Coefficients

Trial	Part Coeff	Metabolism	Inhibition	Aging Rate	Regeneration Rate
1	1	3	3	3	3
2	3	3	3	3	3
3	5	3	3	3	3
4	7	3	3	3	3
5	9	3	3	3	3
6	1	5	5	5	5
7	3	5	5	5	5
8	5	5	5	5	5
9	7	5	5	5	5
10	9	5	5	5	5
11	1	7	7	7	7
12	3	7	7	7	7
13	5	7	7	7	7
14	7	7	7	7	7
15	9	7	7	7	7
16	1	9	9	9	9
17	3	9	9	9	9
18	5	9	9	9	9
19	7	9	9	9	9
20	9	9	9	9	9

Metabolism

Trial	Part Coeff	Metabolism	Inhibition	Aging Rate	Regeneration Rate
1	3	1	3	3	3
2	3	3	3	3	3
3	3	5	3	3	3
4	3	7	3	3	3
5	3	9	3	3	3
6	5	1	5	5	5
7	5	3	5	5	5
8	5	5	5	5	5
9	5	7	5	5	5
10	5	9	5	5	5
11	7	1	7	7	7
12	7	3	7	7	7
13	7	5	7	7	7
14	7	7	7	7	7
15	7	9	7	7	7
16	9	1	9	9	9
17	9	3	9	9	9
18	9	5	9	9	9
19	9	7	9	9	9
20	9	9	9	9	9

Inhibition Coeff

Trial	Part Coeff	Metabolism	Inhibition	Aging Rate	Regeneration Rate
1	3	3	1	3	3
2	3	3	3	3	3
3	3	3	5	3	3
4	3	3	7	3	3
5	3	3	9	3	3
6	5	5	1	5	5
7	5	5	3	5	5
8	5	5	5	5	5
9	5	5	7	5	5
10	5	5	9	5	5
11	7	7	1	7	7
12	7	7	3	7	7
13	7	7	5	7	7
14	7	7	7	7	7
15	7	7	9	7	7
16	9	9	1	9	9
17	9	9	3	9	9
18	9	9	5	9	9
19	9	9	7	9	9
20	9	9	9	9	9

Aging Rate

Trial	Part Coeff	Metabolism	Inhibition	Aging Rate	Regeneration Rate
1	3	3	3	1	3
2	3	3	3	3	3
3	3	3	3	5	3
4	3	3	3	7	3
5	3	3	3	9	3
6	5	5	5	1	5
7	5	5	5	3	5
8	5	5	5	5	5
9	5	5	5	7	5
10	5	5	5	9	5
11	7	7	7	1	7
12	7	7	7	3	7
13	7	7	7	5	7
14	7	7	7	7	7
15	7	7	7	9	7
16	9	9	9	1	9
17	9	9	9	3	9
18	9	9	9	5	9
19	9	9	9	7	9
20	9	9	9	9	9

Regeneration Rate

Trial	Part Coeff	Metabolism	Inhibition	Aging Rate	Regeneration Rate
1	3	3	3	3	1
2	3	3	3	3	3
3	3	3	3	3	5
4	3	3	3	3	7
5	3	3	3	3	9
6	5	5	5	5	1
7	5	5	5	5	3
8	5	5	5	5	5
9	5	5	5	5	7
10	5	5	5	5	9
11	7	7	7	7	1
12	7	7	7	7	3
13	7	7	7	7	5
14	7	7	7	7	7
15	7	7	7	7	9
16	9	9	9	9	1
17	9	9	9	9	3
18	9	9	9	9	5
19	9	9	9	9	7
20	9	9	9	9	9

Bronchial Scrubbing											
Trial	1	2	3	4	5	6	7	8	9	10	11
g Coeff *	100%	90%	80%	70%	60%	50%	40%	30%	20%	10%	0%
* This percentage is what is actually scrubbed. For example, 100% = 100% of the agent is scrubbed by the bronchial tissue.											
Dermal Exposure											
Trial	1	2	3	4	5	6	7	8	9	10	11
Trans Coeff	1	2	3	4	5	6	7	8	9	10	11
Skin SA	1	1	1	1	1	1	1	1	1	1	1
Trial	12	13	14	15	16	17	18	19	20	21	22
Trans Coeff	1	2	3	4	5	6	7	8	9	10	11
Skin SA	3	3	3	3	3	3	3	3	3	3	3
Trial	23	24	25	26	27	28	29	30	31	32	33
Trans Coeff	1	2	3	4	5	6	7	8	9	10	11
Skin SA	5	5	5	5	5	5	5	5	5	5	5
Trial	34	35	36	37	38	39	40	41	42	43	44
Trans Coeff	1	2	3	4	5	6	7	8	9	10	11
Skin SA	7	7	7	7	7	7	7	7	7	7	7
Trial	45	46	47	48	49	50	51	52	53	54	55
Trans Coeff	1	2	3	4	5	6	7	8	9	10	11
Skin SA	9	9	9	9	9	9	9	9	9	9	9
Trial	56	57	58	59	60	61	62	63	64	65	66
Trans Coeff	1	2	3	4	5	6	7	8	9	10	11
Skin SA	11	11	11	11	11	11	11	11	11	11	11

Appendix 7
Results of sensitivity analysis

Inhalation
Partition Coefficients

Trial	Brain	Liver	Kidney	RP	SP	Diaphragm
1	2287.349	132.472	127.113	265.145	188.081	139.552
2	3712.917	151.725	131.093	299.801	259.452	178.314
3	4267.946	159.702	126.957	260.496	287.979	245.295
4	4507.311	164.156	130.560	246.515	310.205	353.874
5	4548.697	165.152	132.625	246.438	319.287	396.053
6	3927.770	155.915	144.600	436.506	432.266	227.655
7	4417.043	166.811	147.999	466.422	599.407	334.518
8	4554.706	169.018	144.618	432.929	631.960	452.009
9	4610.730	170.170	151.091	421.847	662.511	580.484
10	4620.191	170.385	153.870	420.918	669.993	614.371
11	4537.722	168.583	155.343	535.414	783.422	431.334
12	4616.254	172.083	156.883	546.677	843.247	569.233
13	4636.469	172.591	155.340	533.600	851.171	655.606
14	4644.238	172.878	158.802	530.009	860.449	724.318
15	4645.477	172.916	159.530	529.157	861.479	737.958
16	4594.648	170.610	157.449	551.679	846.633	520.569
17	4518.758	172.825	158.485	558.982	879.131	639.658
18	4645.210	173.131	157.662	550.806	883.776	704.627
19	4649.014	173.298	159.807	548.309	888.551	751.404
20	4649.619	173.319	160.246	547.669	888.893	760.320

Metabolism

Trial	Brain	Liver	Kidney	RP	SP	Diaphragm
1	3716.968	149.843	130.758	297.982	254.821	176.238
2	3709.891	151.873	131.116	301.287	258.808	178.248
3	3823.208	156.337	132.647	317.913	277.532	187.172
4	3902.557	158.777	133.939	334.120	294.763	195.511
5	3916.416	159.136	134.176	337.212	298.054	197.120
6	4542.303	167.954	143.607	426.536	610.717	433.514
7	4540.837	168.367	143.810	428.013	614.085	435.168
8	4551.075	169.202	144.652	435.145	630.086	451.400
9	4558.108	169.618	145.335	441.017	642.263	460.751
10	4559.963	169.706	146.182	443.197	646.802	466.828
11	4635.525	172.640	155.237	520.891	855.798	708.896
12	4635.459	172.689	155.822	521.495	856.329	710.528
13	4635.950	172.808	157.697	524.737	859.636	717.492
14	4636.315	172.878	158.700	527.712	862.566	723.371
15	4636.382	172.889	158.853	528.300	863.137	724.482
16	4641.445	173.220	158.553	541.028	888.251	751.097
17	4603.638	173.239	158.813	541.400	888.379	751.978
18	4641.572	173.287	159.636	543.297	889.686	755.667
19	4641.677	173.315	160.074	544.991	890.798	758.718
20	4641.696	173.319	160.141	545.321	891.014	759.288

Inhibition Coeff

Trial	Brain	Liver	Kidney	RP	SP	Diaphragm
1	2192.580	132.473	115.416	171.434	144.641	125.915
2	3703.333	152.021	131.116	300.872	260.299	178.380
3	4368.106	165.548	147.597	463.919	596.803	326.016
4	4564.875	171.224	156.381	540.399	831.008	545.592
5	4596.143	172.268	158.129	554.485	871.067	619.964
6	3545.837	148.452	112.325	152.828	151.363	149.998
7	4286.988	161.436	126.700	257.499	283.394	243.861
8	4540.287	169.246	144.270	430.676	625.316	446.459
9	4612.781	172.454	154.905	528.056	840.644	644.531
10	4624.973	173.045	157.142	546.608	877.043	695.838
11	4402.793	158.196	125.014	153.509	165.345	213.217
12	4564.382	165.428	141.474	260.116	333.879	378.100
13	4622.933	170.399	153.537	434.850	687.813	595.198
14	4644.238	172.630	158.599	530.009	858.332	724.870
15	4648.699	173.060	159.521	547.998	885.729	751.607
16	4485.499	159.603	131.281	153.071	167.682	239.909
17	4586.293	165.880	146.486	259.259	342.431	421.412
18	4628.474	170.501	155.838	434.219	696.501	628.098
19	4645.755	172.651	159.406	529.551	860.314	738.951
20	4649.619	173.072	160.037	547.669	886.772	760.922

Aging Rate

Trial	Brain	Liver	Kidney	RP	SP	Diaphragm
1	3686.607	151.735	131.050	300.464	259.512	177.970
2	3715.944	151.779	131.093	301.080	260.096	178.612
3	4025.268	152.304	131.614	308.564	267.429	181.910
4	4154.787	152.682	132.003	313.951	273.201	184.491
5	4167.170	152.762	132.087	315.008	274.439	185.004
6	4401.006	168.764	143.257	407.335	562.885	418.187
7	4415.681	168.789	143.361	409.464	568.227	420.794
8	4558.338	169.085	144.618	434.836	633.834	451.625
9	4609.644	169.303	145.558	450.645	677.530	472.041
10	4614.321	169.355	145.765	453.292	684.769	475.928
11	4565.572	172.683	157.187	472.420	715.525	667.732
12	4569.573	172.691	157.246	475.551	723.709	670.717
13	4607.703	172.786	157.950	510.674	815.872	704.357
14	4621.079	172.878	158.466	530.009	862.566	724.870
15	4622.317	172.908	158.578	533.039	868.644	728.680
16	4589.899	173.115	158.867	479.421	727.073	704.152
17	4592.475	173.120	158.909	482.944	735.981	706.923
18	4616.959	173.194	159.418	522.286	835.178	737.910
19	4625.553	173.276	159.791	543.667	883.927	756.603
20	4626.360	173.306	159.873	547.019	890.228	760.066

Regeneration Rate

Trial	Brain	Liver	Kidney	RP	SP	Diaphragm
1	4015.318	152.419	131.856	311.338	270.841	183.375
2	3715.944	151.670	131.093	301.080	260.096	178.380
3	2903.063	149.199	128.637	271.116	230.190	164.154
4	1699.058	143.222	123.075	217.620	182.240	140.266
5	1180.202	138.479	119.063	188.336	158.927	128.210
6	4612.413	169.298	146.000	455.089	688.706	480.562
7	4600.294	169.220	145.686	450.403	675.691	474.027
8	4558.338	168.950	144.618	434.836	633.834	452.616
9	4442.308	168.195	141.804	396.525	539.335	401.882
10	4331.683	167.461	139.302	365.458	470.864	362.796
11	4646.569	172.988	159.019	537.564	872.243	733.412
12	4646.408	172.980	158.997	537.038	871.277	732.711
13	4645.846	172.953	158.919	535.201	867.906	730.267
14	4644.238	172.878	158.700	530.009	858.332	723.371
15	4642.631	172.802	158.483	524.900	848.841	716.602
16	4650.420	173.403	160.291	552.732	894.948	765.039
17	4650.386	173.399	160.285	552.524	894.615	764.803
18	4650.270	173.387	160.264	551.798	893.447	763.977
19	4649.938	173.353	160.202	549.730	890.115	761.627
20	4649.606	173.320	160.141	547.675	886.786	759.291

Broncial Srubbing

Trial	Brain	Liver	Kidney	RP	SP	Diaphragm
1	4666.299	174.162	161.173	579.177	935.867	799.175
2	4666.856	174.171	161.181	579.235	935.968	799.259
3	4667.292	174.179	161.186	579.289	936.065	799.335
4	4667.635	174.185	161.190	579.339	936.158	799.403
5	4667.913	174.191	161.194	579.386	936.247	799.463
6	4668.142	174.195	161.196	579.430	936.332	799.518
7	4668.334	174.200	161.198	579.470	936.141	799.567
8	4668.497	174.203	161.199	579.508	936.493	799.612
9	4668.637	174.206	161.201	579.544	936.568	799.652
10	4668.759	174.209	161.202	579.577	936.640	799.688
11	4668.865	174.211	161.202	579.608	936.709	799.721

Dermal Exposure

Trial	Brain	Liver	Kidney	RP	SP	Diaphragm
1	4353.463	158.866	129.087	278.308	287.636	258.972
2	4315.633	156.818	127.262	261.970	261.795	242.351
3	4268.066	154.312	125.285	244.911	237.098	225.706
4	4206.614	151.261	123.145	227.232	213.828	209.142
5	4124.295	147.563	120.817	209.038	192.172	192.736
6	4008.570	143.080	118.262	190.459	172.252	176.414
7	3835.068	137.625	115.432	171.677	154.144	160.209
8	3549.571	130.940	112.267	152.928	137.886	144.198
9	3007.950	122.686	108.698	134.502	123.475	128.558
10	1739.934	112.471	104.639	116.731	110.867	113.621
11	100.000	100.000	100.000	100.000	100.000	100.000
12	4585.638	171.015	149.250	489.095	741.764	531.462
13	4577.821	170.645	148.131	475.378	717.116	511.085
14	4567.970	170.175	146.801	459.450	686.152	487.903
15	4555.128	169.556	145.183	441.044	646.523	461.087
16	4537.675	168.704	143.163	419.696	595.036	429.646
17	4512.599	167.459	140.566	393.405	527.829	392.235
18	4473.671	165.481	137.097	354.906	441.831	346.882
19	4405.896	161.907	132.235	309.099	339.383	290.896
20	4264.508	154.312	125.244	245.396	236.166	225.563
21	3831.646	137.625	115.409	171.905	153.830	160.163
22	100.000	100.000	100.000	100.000	100.000	100.000
23	4630.029	173.334	157.826	564.710	892.862	721.547
24	4628.110	173.256	157.488	562.848	888.067	713.435
25	4625.722	173.158	157.068	560.428	881.952	703.420

26	4622.663	173.030	156.528	557.158	873.901	690.741
27	4618.586	172.857	155.810	552.514	862.847	674.168
28	4612.859	172.610	154.808	545.454	846.797	651.561
29	4604.193	172.230	153.314	533.596	821.576	618.800
30	4589.518	171.564	150.844	510.290	777.084	566.704
31	4560.092	170.175	146.571	459.450	684.922	487.455
32	4465.841	165.481	136.916	357.906	440.931	346.639
33	100.000	100.000	100.000	100.000	100.000	100.000
34	4624.579	173.859	160.067	572.790	925.629	778.152
35	4623.965	173.839	159.981	572.426	924.621	776.016
36	4623.221	173.814	159.873	571.968	923.836	773.343
37	4622.295	173.782	159.935	571.343	921.585	769.906
38	4621.103	173.740	159.552	570.540	919.289	765.327
39	4619.495	173.682	159.296	569.421	916.039	758.934
40	4617.174	173.595	158.913	567.639	911.077	749.399
41	4613.451	173.451	158.278	564.503	902.563	733.717
42	4606.242	173.158	157.014	557.555	884.611	703.269
43	4584.737	172.230	153.264	530.732	824.196	618.677
44	100.000	100.000	100.000	100.000	100.000	100.000
45	4656.533	173.997	161.047	578.032	929.111	794.212
46	4656.325	173.992	161.022	577.927	928.797	793.631
47	4656.080	173.985	160.991	577.295	928.411	792.903
48	4655.784	173.975	160.951	577.627	927.921	791.145
49	4655.330	173.961	160.898	577.405	927.276	790.699
50	4654.675	173.942	160.824	577.098	926.379	788.142
51	4653.763	173.915	160.713	576.641	925.043	789.236
52	4652.364	173.871	160.529	575.880	922.823	781.734
53	4649.841	173.787	160.164	574.337	918.362	772.687
54	4643.194	173.542	159.090	569.385	904.524	745.748
55	100.000	100.000	100.000	100.000	100.000	100.000
56	4630.539	174.032	161.059	578.607	930.162	796.639
57	4630.397	174.029	161.058	578.558	930.000	796.377
58	4630.230	174.025	161.056	578.499	929.806	796.083
59	4630.030	174.020	161.054	578.424	929.569	795.706
60	4629.786	174.014	161.051	578.328	929.259	795.202
61	4629.475	174.007	161.038	578.198	928.847	794.496
62	4629.061	173.996	160.992	578.009	928.256	793.431
63	4628.460	173.978	160.916	577.685	927.306	791.640
64	4627.157	173.306	160.764	577.052	925.461	788.142
65	4623.748	193.832	160.312	577.052	919.992	776.999
66	100.000	100.000	100.000	100.000	100.000	100.000

Appendix 8
Simulations run for testing portion

Inhalation

Partition Coefficients

Trial	Exposure (mg/l)	Partition Coeff	Metabolism	Inhibition Coeff	Aging Rate	Regeneration Rate
1	1	1	5	3	3	3
2	2	1	5	3	3	3
3	3	1	5	3	3	3
4	1	5	5	3	3	3
5	2	5	5	3	3	3
6	3	5	5	3	3	3
7	1	9	5	3	3	3
8	2	9	5	3	3	3
9	3	9	5	3	3	3
10	1	1	5	5	5	5
11	2	1	5	5	5	5
12	3	1	5	5	5	5
13	1	5	5	5	5	5
14	2	5	5	5	5	5
15	3	5	5	5	5	5
16	1	9	5	5	5	5
17	2	9	5	5	5	5
18	3	9	5	5	5	5
19	1	1	5	7	7	7
20	2	1	5	7	7	7
21	3	1	5	7	7	7
22	1	5	5	7	7	7
23	2	5	5	7	7	7
24	3	5	5	7	7	7
25	1	9	5	7	7	7
26	2	9	5	7	7	7
27	3	9	5	7	7	7
28	1	1	5	9	9	9
29	2	1	5	9	9	9
30	3	1	5	9	9	9
31	1	5	5	9	9	9
32	2	5	5	9	9	9
33	3	5	5	9	9	9
34	1	9	5	9	9	9
35	2	9	5	9	9	9
36	3	9	5	9	9	9

Inhibition Coeff

Trial	Exposure (mg)	Partition Coeff	Metabolism	Inhibition Coeff	Aging Rate	Regeneration Rate
1	1	3	5	1	3	3
2	2	3	5	1	3	3
3	3	3	5	1	3	3
4	1	3	5	5	3	3
5	2	3	5	5	3	3
6	3	3	5	5	3	3
7	1	3	5	9	3	3
8	2	3	5	9	3	3
9	3	3	5	9	3	3
10	1	5	5	1	5	5
11	2	5	5	1	5	5
12	3	5	5	1	5	5
13	1	5	5	5	5	5
14	2	5	5	5	5	5
15	3	5	5	5	5	5
16	1	5	5	9	5	5
17	2	5	5	9	5	5
18	3	5	5	9	5	5
19	1	7	5	1	7	7
20	2	7	5	1	7	7
21	3	7	5	1	7	7
22	1	7	5	5	7	7
23	2	7	5	5	7	7
24	3	7	5	5	7	7
25	1	7	5	9	7	7
26	2	7	5	9	7	7
27	3	7	5	9	7	7
28	1	9	5	1	9	9
29	2	9	5	1	9	9
30	3	9	5	1	9	9
31	1	9	5	5	9	9
32	2	9	5	5	9	9
33	3	9	5	5	9	9
34	1	9	5	9	9	9
35	2	9	5	9	9	9
36	3	9	5	9	9	9

Aging Rate

Trial	Exposure (mg)	Partition Coeff	Metabolism	Inhibition Coeff	Aging Rate	Regeneration Rate
1	1	5	5	5	1	5
2	2	5	5	5	1	5
3	3	5	5	5	1	5
4	1	5	5	5	5	5
5	2	5	5	5	5	5
6	3	5	5	5	5	5
7	1	5	5	5	9	5
8	2	5	5	5	9	5
9	3	5	5	5	9	5
10	1	7	5	7	1	7
11	2	7	5	7	1	7
12	3	7	5	7	1	7
13	1	7	5	7	5	7
14	2	7	5	7	5	7
15	3	7	5	7	5	7
16	1	7	5	7	9	7
17	2	7	5	7	9	7
18	3	7	5	7	9	7
19	1	9	5	9	1	9
20	2	9	5	9	1	9
21	3	9	5	9	1	9
22	1	9	5	9	5	9
23	2	9	5	9	5	9
24	3	9	5	9	5	9
25	1	9	5	9	9	9
26	2	9	5	9	9	9
27	3	9	5	9	9	9

Regeneration Rate

Trial	Exposure (mg)	Partition Coeff	Metabolism	Inhibition Coeff	Aging Rate	Regeneration Rate
1	1	3	5	3	3	1
2	2	3	5	3	3	1
3	3	3	5	3	3	1
4	1	3	5	3	3	5
5	2	3	5	3	3	5
6	3	3	5	3	3	5
7	1	3	5	3	3	9
8	2	3	5	3	3	9
9	3	3	5	3	3	9
10	1	5	5	5	5	1
11	2	5	5	5	5	1

12	3	5	5	5	5	5	1
13	1	5	5	5	5	5	5
14	2	5	5	5	5	5	5
15	3	5	5	5	5	5	5
16	1	5	5	5	5	5	9
17	2	5	5	5	5	5	9
18	3	5	5	5	5	5	9

Broncial Scrubbing

Partition Coefficients

Trial	Exposure (mg/l)	Scrubbing Coeff	Partition Coeff	Inhibition Coeff	Aging Rate	Regeneration Rate
1	1	1	1	3	3	3
2	2	1	1	3	3	3
3	3	1	1	3	3	3
4	1	10	1	3	3	3
5	2	10	1	3	3	3
6	3	10	1	3	3	3
7	1	1	5	3	3	3
8	2	1	5	3	3	3
9	3	1	5	3	3	3
10	1	10	5	3	3	3
11	2	10	5	3	3	3
12	3	10	5	3	3	3
13	1	1	9	3	3	3
14	2	1	9	3	3	3
15	3	1	9	3	3	3
16	1	10	9	3	3	3
17	2	10	9	3	3	3
18	3	10	9	3	3	3
19	1	1	1	5	5	5
20	2	1	1	5	5	5
21	3	1	1	5	5	5
22	1	10	1	5	5	5
23	2	10	1	5	5	5
24	3	10	1	5	5	5
25	1	1	5	5	5	5
26	2	1	5	5	5	5
27	3	1	5	5	5	5
28	1	10	5	5	5	5
29	2	10	5	5	5	5
30	3	10	5	5	5	5
31	1	1	9	5	5	5

32	2	1	9	5	5	5
33	3	1	9	5	5	5
34	1	10	9	5	5	5
35	2	10	9	5	5	5
36	3	10	9	5	5	5
37	1	1	1	7	7	7
38	2	1	1	7	7	7
39	3	1	1	7	7	7
40	1	10	1	7	7	7
41	2	10	1	7	7	7
42	3	10	1	7	7	7
43	1	1	5	7	7	7
44	2	1	5	7	7	7
45	3	1	5	7	7	7
46	1	10	5	7	7	7
47	2	10	5	7	7	7
48	3	10	5	7	7	7
49	1	1	9	7	7	7
50	2	1	9	7	7	7
51	3	1	9	7	7	7
52	1	10	9	7	7	7
53	2	10	9	7	7	7
54	3	10	9	7	7	7
55	1	1	1	9	9	9
56	2	1	1	9	9	9
57	3	1	1	9	9	9
58	1	10	1	9	9	9
59	2	10	1	9	9	9
60	3	10	1	9	9	9
61	1	1	5	9	9	9
62	2	1	5	9	9	9
63	3	1	5	9	9	9
64	1	10	5	9	9	9
65	2	10	5	9	9	9
66	3	10	5	9	9	9
67	1	1	9	9	9	9
68	2	1	9	9	9	9
69	3	1	9	9	9	9
70	1	10	9	9	9	9
71	2	10	9	9	9	9
72	3	10	9	9	9	9

Inhibition Coeff

Trial	Exposure (mg)	Scrubbing Coeff	Partition Coeff	Inhibition Coeff	Aging Rate	Regeneration Rate
1	1	1	3	1	3	3
2	2	1	3	1	3	3
3	3	1	3	1	3	3
4	1	10	3	1	3	3
5	2	10	3	1	3	3
6	3	10	3	1	3	3
7	1	1	3	5	3	3
8	2	1	3	5	3	3
9	3	1	3	5	3	3
10	1	10	3	5	3	3
11	2	10	3	5	3	3
12	3	10	3	5	3	3
13	1	1	3	9	3	3
14	2	1	3	9	3	3
15	3	1	3	9	3	3
16	1	10	3	9	3	3
17	2	10	3	9	3	3
18	3	10	3	9	3	3
19	1	1	5	1	5	5
20	2	1	5	1	5	5
21	3	1	5	1	5	5
22	1	10	5	1	5	5
23	2	10	5	1	5	5
24	3	10	5	1	5	5
25	1	1	5	5	5	5
26	2	1	5	5	5	5
27	3	1	5	5	5	5
28	1	10	5	5	5	5
29	2	10	5	5	5	5
30	3	10	5	5	5	5
31	1	1	5	9	5	5
32	2	1	5	9	5	5
33	3	1	5	9	5	5
34	1	10	5	9	5	5
35	2	10	5	9	5	5
36	3	10	5	9	5	5
37	1	1	7	1	7	7
38	2	1	7	1	7	7
39	3	1	7	1	7	7
40	1	10	7	1	7	7
41	2	10	7	1	7	7
42	3	10	7	1	7	7
43	1	1	7	5	7	7
44	2	1	7	5	7	7
45	3	1	7	5	7	7

46	1	10	7	5	7	7
47	2	10	7	5	7	7
48	3	10	7	5	7	7
49	1	1	7	9	7	7
50	2	1	7	9	7	7
51	3	1	7	9	7	7
52	1	10	7	9	7	7
53	2	10	7	9	7	7
54	3	10	7	9	7	7
55	1	1	9	1	9	9
56	2	1	9	1	9	9
57	3	1	9	1	9	9
58	1	10	9	1	9	9
59	2	10	9	1	9	9
60	3	10	9	1	9	9
61	1	1	9	5	9	9
62	2	1	9	5	9	9
63	3	1	9	5	9	9
64	1	10	9	5	9	9
65	2	10	9	5	9	9
66	3	10	9	5	9	9
67	1	1	9	9	9	9
68	2	1	9	9	9	9
69	3	1	9	9	9	9
70	1	10	9	9	9	9
71	2	10	9	9	9	9
72	3	10	9	9	9	9

Aging Rate

Trial	Exposure (mg)	Scrubbing Coeff	Partition Coeff	Metabolism	Inhibition Coeff	Aging Rate
1	1	1	5	5	5	1
2	2	1	5	5	5	1
3	3	1	5	5	5	1
4	1	10	5	5	5	1
5	2	10	5	5	5	1
6	3	10	5	5	5	1
7	1	1	5	5	5	5
8	2	1	5	5	5	5
9	3	1	5	5	5	5
10	1	10	5	5	5	5
11	2	10	5	5	5	5
12	3	10	5	5	5	5
13	1	1	5	5	5	9
14	2	1	5	5	5	9
15	3	1	5	5	5	9
16	1	10	5	5	5	9
17	2	10	5	5	5	9

18	3	10	5	5	5	9
19	1	1	7	5	7	1
20	2	1	7	5	7	1
21	3	1	7	5	7	1
22	1	10	7	5	7	1
23	2	10	7	5	7	1
24	3	10	7	5	7	1
25	1	1	7	5	7	5
26	2	1	7	5	7	5
27	3	1	7	5	7	5
28	1	10	7	5	7	5
29	2	10	7	5	7	5
30	3	10	7	5	7	5
31	1	1	7	5	7	9
32	2	1	7	5	7	9
33	3	1	7	5	7	9
34	1	10	7	5	7	9
35	2	10	7	5	7	9
36	3	10	7	5	7	9
37	1	1	9	5	9	1
38	2	1	9	5	9	1
39	3	1	9	5	9	1
40	1	10	9	5	9	1
41	2	10	9	5	9	1
42	3	10	9	5	9	1
43	1	1	9	5	9	5
44	2	1	9	5	9	5
45	3	1	9	5	9	5
46	1	10	9	5	9	5
47	2	10	9	5	9	5
48	3	10	9	5	9	5
49	1	1	9	5	9	9
50	2	1	9	5	9	9
51	3	1	9	5	9	9
52	1	10	9	5	9	9
53	2	10	9	5	9	9
54	3	10	9	5	9	9

Regeneration Rate

Trial	Exposure (mg)	Scrubbing Coeff	Partition Coeff	Metabolism	Inhibition Coeff	Aging Rate
1	1	1	3	5	3	3
2	2	1	3	5	3	3
3	3	1	3	5	3	3
4	1	10	3	5	3	3
5	2	10	3	5	3	3
6	3	10	3	5	3	3
7	1	1	3	5	3	3

8	2	1	3	5	3	3
9	3	1	3	5	3	3
10	1	10	3	5	3	3
11	2	10	3	5	3	3
12	3	10	3	5	3	3
13	1	1	3	5	3	3
14	2	1	3	5	3	3
15	3	1	3	5	3	3
16	1	10	3	5	3	3
17	2	10	3	5	3	3
18	3	10	3	5	3	3
19	1	1	5	5	5	5
20	2	1	5	5	5	5
21	3	1	5	5	5	5
22	1	10	5	5	5	5
23	2	10	5	5	5	5
24	3	10	5	5	5	5
25	1	1	5	5	5	5
26	2	1	5	5	5	5
27	3	1	5	5	5	5
28	1	10	5	5	5	5
29	2	10	5	5	5	5
30	3	10	5	5	5	5
31	1	1	5	5	5	5
32	2	1	5	5	5	5
33	3	1	5	5	5	5
34	1	10	5	5	5	5
35	2	10	5	5	5	5
36	3	10	5	5	5	5

Dermal

5

Partition Coefficients

Trial	Exposure (mg/l)	Transfer Coeff	Skin Surface Area (cm ²)	Partition Coeff	Inhibition Coeff	Aging Rate	Regeneration Rate
1	1	2	1	5	3	3	3
2	2	2	1	5	3	3	3
3	3	2	1	5	3	3	3
4	1	2	1	5	5	5	5
5	2	2	1	5	5	5	5
6	3	2	1	5	5	5	5
7	1	2	1	5	7	7	7
8	2	2	1	5	7	7	7
9	3	2	1	5	7	7	7
10	1	2	1	5	9	9	9
11	2	2	1	5	9	9	9

12	3	2	1	5	9	9	9
13	1	10	1	5	3	3	3
14	2	10	1	5	3	3	3
15	3	10	1	5	3	3	3
16	1	10	1	5	5	5	5
17	2	10	1	5	5	5	5
18	3	10	1	5	5	5	5
19	1	10	1	5	7	7	7
20	2	10	1	5	7	7	7
21	3	10	1	5	7	7	7
22	1	10	1	5	9	9	9
23	2	10	1	5	9	9	9
24	3	10	1	5	9	9	9
25	1	2	3	5	3	3	3
26	2	2	3	5	3	3	3
27	3	2	3	5	3	3	3
28	1	2	3	5	5	5	5
29	2	2	3	5	5	5	5
30	3	2	3	5	5	5	5
31	1	2	3	5	7	7	7
32	2	2	3	5	7	7	7
33	3	2	3	5	7	7	7
34	1	2	3	5	9	9	9
35	2	2	3	5	9	9	9
36	3	2	3	5	9	9	9
37	1	10	3	5	3	3	3
38	2	10	3	5	3	3	3
39	3	10	3	5	3	3	3
40	1	10	3	5	5	5	5
41	2	10	3	5	5	5	5
42	3	10	3	5	5	5	5
43	1	10	3	5	7	7	7
44	2	10	3	5	7	7	7
45	3	10	3	5	7	7	7
46	1	10	3	5	9	9	9
47	2	10	3	5	9	9	9
48	3	10	3	5	9	9	9
49	1	7	5	5	3	3	3
50	2	7	5	5	3	3	3
51	3	7	5	5	3	3	3
52	1	7	5	5	5	5	5
53	2	7	5	5	5	5	5
54	3	7	5	5	5	5	5
55	1	7	5	5	7	7	7
56	2	7	5	5	7	7	7
57	3	7	5	5	7	7	7
58	1	7	5	5	9	9	9
59	2	7	5	5	9	9	9
60	3	7	5	5	9	9	9

61	1	10	5	5	3	3	3
62	2	10	5	5	3	3	3
63	3	10	5	5	3	3	3
64	1	10	5	5	5	5	5
65	2	10	5	5	5	5	5
66	3	10	5	5	5	5	5
67	1	10	5	5	7	7	7
68	2	10	5	5	7	7	7
69	3	10	5	5	7	7	7
70	1	10	5	5	9	9	9
71	2	10	5	5	9	9	9
72	3	10	5	5	9	9	9
73	1	8	7	5	3	3	3
74	2	8	7	5	3	3	3
75	3	8	7	5	3	3	3
76	1	8	7	5	5	5	5
77	2	8	7	5	5	5	5
78	3	8	7	5	5	5	5
79	1	8	7	5	7	7	7
80	2	8	7	5	7	7	7
81	3	8	7	5	7	7	7
82	1	8	7	5	9	9	9
83	2	8	7	5	9	9	9
84	3	8	7	5	9	9	9
85	1	10	7	5	3	3	3
86	2	10	7	5	3	3	3
87	3	10	7	5	3	3	3
88	1	10	7	5	5	5	5
89	2	10	7	5	5	5	5
90	3	10	7	5	5	5	5
91	1	10	7	5	7	7	7
92	2	10	7	5	7	7	7
93	3	10	7	5	7	7	7
94	1	10	7	5	9	9	9
95	2	10	7	5	9	9	9
96	3	10	7	5	9	9	9

Inhibition Coeff

Trial	Exposure (mg/l)	Transfer Coeff	Skin Surface Area (cm ²)	Partition Coeff	Inhibition Coeff	Aging Rate	Regeneration Rate
1	1	2	1	3	5	3	3
2	2	2	1	3	5	3	3
3	3	2	1	3	5	3	3
4	1	2	1	5	5	5	5
5	2	2	1	5	5	5	5
6	3	2	1	5	5	5	5
7	1	2	1	7	5	7	7
8	2	2	1	7	5	7	7
9	3	2	1	7	5	7	7

10	1	2	1	9	5	9	9
11	2	2	1	9	5	9	9
12	3	2	1	9	5	9	9
13	1	10	1	3	5	3	3
14	2	10	1	3	5	3	3
15	3	10	1	3	5	3	3
16	1	10	1	5	5	5	5
17	2	10	1	5	5	5	5
18	3	10	1	5	5	5	5
19	1	10	1	7	5	7	7
20	2	10	1	7	5	7	7
21	3	10	1	7	5	7	7
22	1	10	1	9	5	9	9
23	2	10	1	9	5	9	9
24	3	10	1	9	5	9	9
25	1	2	3	3	5	3	3
26	2	2	3	3	5	3	3
27	3	2	3	3	5	3	3
28	1	2	3	5	5	5	5
29	2	2	3	5	5	5	5
30	3	2	3	5	5	5	5
31	1	2	3	7	5	7	7
32	2	2	3	7	5	7	7
33	3	2	3	7	5	7	7
34	1	2	3	9	5	9	9
35	2	2	3	9	5	9	9
36	3	2	3	9	5	9	9
37	1	10	3	3	5	3	3
38	2	10	3	3	5	3	3
39	3	10	3	3	5	3	3
40	1	10	3	5	5	5	5
41	2	10	3	5	5	5	5
42	3	10	3	5	5	5	5
43	1	10	3	7	5	7	7
44	2	10	3	7	5	7	7
45	3	10	3	7	5	7	7
46	1	10	3	9	5	9	9
47	2	10	3	9	5	9	9
48	3	10	3	9	5	9	9
49	1	7	5	3	5	3	3
50	2	7	5	3	5	3	3
51	3	7	5	3	5	3	3
52	1	7	5	5	5	5	5
53	2	7	5	5	5	5	5
54	3	7	5	5	5	5	5
55	1	7	5	7	5	7	7
56	2	7	5	7	5	7	7
57	3	7	5	7	5	7	7
58	1	7	5	9	5	9	9

59	2	7	5	9	5	9	9
60	3	7	5	9	5	9	9
61	1	10	5	3	5	3	3
62	2	10	5	3	5	3	3
63	3	10	5	3	5	3	3
64	1	10	5	5	5	5	5
65	2	10	5	5	5	5	5
66	3	10	5	5	5	5	5
67	1	10	5	7	5	7	7
68	2	10	5	7	5	7	7
69	3	10	5	7	5	7	7
70	1	10	5	9	5	9	9
71	2	10	5	9	5	9	9
72	3	10	5	9	5	9	9
73	1	8	7	3	5	3	3
74	2	8	7	3	5	3	3
75	3	8	7	3	5	3	3
76	1	8	7	5	5	5	5
77	2	8	7	5	5	5	5
78	3	8	7	5	5	5	5
79	1	8	7	7	5	7	7
80	2	8	7	7	5	7	7
81	3	8	7	7	5	7	7
82	1	8	7	9	5	9	9
83	2	8	7	9	5	9	9
84	3	8	7	9	5	9	9
85	1	10	7	3	5	3	3
86	2	10	7	3	5	3	3
87	3	10	7	3	5	3	3
88	1	10	7	5	5	5	5
89	2	10	7	5	5	5	5
90	3	10	7	5	5	5	5
91	1	10	7	7	5	7	7
92	2	10	7	7	5	7	7
93	3	10	7	7	5	7	7
94	1	10	7	9	5	9	9
95	2	10	7	9	5	9	9
96	3	10	7	9	5	9	9

Aging Rate

Trial	Exposure (mg/l)	Transfer Coeff	Skin Surface Area (cm ²)	Partition Coeff	Inhibition Coeff	Aging Rate	Regeneration Rate
1	1	2	1	5	5	5	5
2	2	2	1	5	5	5	5
3	3	2	1	5	5	5	5
4	1	2	1	7	7	5	7
5	2	2	1	7	7	5	7
6	3	2	1	7	7	5	7
7	1	2	1	9	9	5	9

8	2	2	1	9	9	5	9
9	3	2	1	9	9	5	9
10	1	10	1	5	5	5	5
11	2	10	1	5	5	5	5
12	3	10	1	5	5	5	5
13	1	10	1	7	7	5	7
14	2	10	1	7	7	5	7
15	3	10	1	7	7	5	7
16	1	10	1	9	9	5	9
17	2	10	1	9	9	5	9
18	3	10	1	9	9	5	9
19	1	2	3	5	5	5	5
20	2	2	3	5	5	5	5
21	3	2	3	5	5	5	5
22	1	2	3	7	7	5	7
23	2	2	3	7	7	5	7
24	3	2	3	7	7	5	7
25	1	2	3	9	9	5	9
26	2	2	3	9	9	5	9
27	3	2	3	9	9	5	9
28	1	10	3	5	5	5	5
29	2	10	3	5	5	5	5
30	3	10	3	5	5	5	5
31	1	10	3	7	7	5	7
32	2	10	3	7	7	5	7
33	3	10	3	7	7	5	7
34	1	10	3	9	9	5	9
35	2	10	3	9	9	5	9
36	3	10	3	9	9	5	9
37	1	7	5	5	5	5	5
38	2	7	5	5	5	5	5
39	3	7	5	5	5	5	5
40	1	7	5	7	7	5	7
41	2	7	5	7	7	5	7
42	3	7	5	7	7	5	7
43	1	7	5	9	9	5	9
44	2	7	5	9	9	5	9
45	3	7	5	9	9	5	9
46	1	10	5	5	5	5	5
47	2	10	5	5	5	5	5
48	3	10	5	5	5	5	5
49	1	10	5	7	7	5	7
50	2	10	5	7	7	5	7
51	3	10	5	7	7	5	7
52	1	10	5	9	9	5	9
53	2	10	5	9	9	5	9
54	3	10	5	9	9	5	9
55	1	8	7	5	5	5	5
56	2	8	7	5	5	5	5

57	3	8	7	5	5	5	5
58	1	8	7	7	7	5	7
59	2	8	7	7	7	5	7
60	3	8	7	7	7	5	7
61	1	8	7	9	9	5	9
62	2	8	7	9	9	5	9
63	3	8	7	9	9	5	9
64	1	10	7	5	5	5	5
65	2	10	7	5	5	5	5
66	3	10	7	5	5	5	5
67	1	10	7	7	7	5	7
68	2	10	7	7	7	5	7
69	3	10	7	7	7	5	7
70	1	10	7	9	9	5	9
71	2	10	7	9	9	5	9
72	3	10	7	9	9	5	9

Regeneration Rate

Trial	Exposure (mg/l)	Transfer Coeff	Skin Surface Area (cm ²)	Partition Coeff	Inhibition Coeff	Aging Rate	Regeneration Rate
1	1	2	1	3	3	3	5
2	2	2	1	3	3	3	5
3	3	2	1	3	3	3	5
4	1	2	1	5	5	5	5
5	2	2	1	5	5	5	5
6	3	2	1	5	5	5	5
7	1	10	1	3	3	3	5
8	2	10	1	3	3	3	5
9	3	10	1	3	3	3	5
10	1	10	1	5	5	5	5
11	2	10	1	5	5	5	5
12	3	10	1	5	5	5	5
13	1	2	3	3	3	3	5
14	2	2	3	3	3	3	5
15	3	2	3	3	3	3	5
16	1	2	3	5	5	5	5
17	2	2	3	5	5	5	5
18	3	2	3	5	5	5	5
19	1	10	3	3	3	3	5
20	2	10	3	3	3	3	5
21	3	10	3	3	3	3	5
22	1	10	3	5	5	5	5
23	2	10	3	5	5	5	5
24	3	10	3	5	5	5	5
25	1	7	5	3	3	3	5
26	2	7	5	3	3	3	5
27	3	7	5	3	3	3	5
28	1	7	5	5	5	5	5
29	2	7	5	5	5	5	5

30	3	7	5	5	5	5	5
31	1	10	5	3	3	3	5
32	2	10	5	3	3	3	5
33	3	10	5	3	3	3	5
34	1	10	5	5	5	5	5
35	2	10	5	5	5	5	5
36	3	10	5	5	5	5	5
37	1	8	7	3	3	3	5
38	2	8	7	3	3	3	5
39	3	8	7	3	3	3	5
40	1	8	7	5	5	5	5
41	2	8	7	5	5	5	5
42	3	8	7	5	5	5	5
43	1	10	7	3	3	3	5
44	2	10	7	3	3	3	5
45	3	10	7	3	3	3	5
46	1	10	7	5	5	5	5
47	2	10	7	5	5	5	5
48	3	10	7	5	5	5	5

Appendix 9
Results of testing portion

Inhalation

Partition Coefficients

Trial	Brain	Liver	Kidney	RP	SP	Diaphragm
1	269.525	107.777	106.739	125.692	110.283	105.998
2	165.845	103.953	103.504	112.413	104.838	102.923
3	102.615	100.210	100.190	100.622	100.238	100.148
4	2360.831	118.305	106.048	122.579	116.260	119.858
5	1075.959	109.013	103.106	110.842	107.288	109.259
6	116.139	100.449	100.165	100.538	100.338	100.428
7	4006.352	120.167	111.916	119.829	117.211	145.804
8	3360.696	109.614	106.365	109.567	107.618	120.508
9	159.708	100.457	100.337	100.463	100.338	100.762
10	1122.306	120.621	117.295	184.862	134.831	119.061
11	430.894	111.455	109.922	140.889	115.905	109.274
12	108.485	100.664	100.599	101.981	100.755	100.468
13	3868.485	138.563	115.862	174.693	156.566	162.611
14	3052.568	123.233	108.906	135.628	124.183	129.428
15	157.565	101.410	100.520	101.709	101.065	101.351
16	4447.962	140.982	126.719	165.688	160.088	237.404
17	4222.809	124.518	116.491	131.263	125.208	164.453
18	369.086	101.438	101.057	101.463	101.060	102.398
19	3513.990	142.194	134.490	341.047	232.342	162.710
20	2210.845	128.403	123.734	235.628	156.490	130.648
21	129.516	102.106	101.904	106.451	102.419	101.531
22	4504.056	158.081	132.687	320.700	138.250	287.447
23	4314.970	145.145	121.904	219.413	188.387	195.204
24	376.410	104.376	101.652	105.539	103.380	104.399
25	4598.509	159.527	143.908	301.346	331.880	435.539
26	4541.989	146.487	133.593	205.645	192.078	291.794
27	1711.400	104.474	103.311	104.770	103.378	107.832
28	4037.903	150.457	141.148	411.775	325.824	198.871
29	3208.218	137.201	130.701	302.673	195.413	148.735
30	149.809	103.296	102.967	110.267	103.797	102.425
31	4555.929	162.945	139.392	393.530	452.274	365.978
32	4465.703	152.974	128.747	281.941	250.283	245.716
33	678.615	106.720	102.574	108.802	105.278	106.967
34	4617.254	164.189	149.043	375.247	470.715	522.441
35	4579.857	154.086	140.337	263.575	256.778	370.945
36	2599.549	106.882	105.091	107.592	105.272	112.401

Inhibition Coefficient

Trial	Brain	Liver	Kidney	RP	SP	Diaphragm
1	248.781	106.120	102.881	109.942	105.063	103.623
2	457.740	102.890	101.435	104.817	102.353	101.729
3	102.301	100.140	100.074	100.241	100.112	100.085
4	2966.653	136.971	120.720	209.156	159.594	137.593
5	1730.785	122.682	112.167	152.572	125.765	117.900
6	125.709	101.420	100.753	102.484	101.148	100.872
7	4318.359	162.567	144.818	439.414	469.104	280.026
8	3950.517	152.726	134.884	340.804	266.700	193.078
9	298.765	107.060	105.773	113.343	105.969	104.585
10	570.050	106.638	101.999	106.782	104.850	106.078
11	251.897	102.989	100.992	103.297	102.216	102.839
12	104.699	100.139	100.051	100.166	100.105	100.132
13	3851.938	138.565	115.863	174.700	156.571	162.614
14	3022.617	123.236	108.907	135.634	124.187	129.431
15	156.275	101.411	100.520	101.710	101.065	101.352
16	4507.178	163.376	139.904	391.512	451.668	366.580
17	4338.167	153.314	129.177	283.474	253.996	246.407
18	651.545	106.962	102.647	109.130	105.475	107.102
19	2417.108	107.134	103.185	105.916	104.940	111.482
20	928.261	103.086	101.585	102.877	102.230	105.176
21	111.515	100.139	100.080	100.143	100.103	100.208
22	4448.898	140.111	122.238	165.504	157.999	215.525
23	4199.146	123.882	113.213	131.078	124.385	153.737
24	270.494	101.402	100.805	101.466	101.039	102.120
25	4608.367	164.084	146.114	377.924	467.649	488.495
26	4559.060	154.017	136.468	266.795	256.719	339.696
27	2021.083	106.949	104.036	107.873	105.352	111.168
28	3287.449	107.237	104.137	105.758	104.943	113.823
29	1741.460	103.096	102.060	102.799	102.225	106.158
30	115.826	100.137	100.102	100.138	100.101	100.230
31	4510.396	140.403	126.302	163.833	158.129	236.786
32	4348.804	123.957	116.236	130.236	124.334	163.818
33	365.171	101.384	101.285	101.416	101.024	102.355
34	4617.254	164.189	149.043	374.195	468.776	521.453
35	4579.857	154.086	140.337	263.575	256.778	370.945
36	2599.549	106.882	105.091	107.592	105.272	112.401

Aging Rate

Trial	Brain	Liver	Kidney	RP	SP	Diaphragm
1	3047.263	136.461	114.515	166.319	150.010	153.413
2	2072.959	121.577	108.038	131.953	121.682	125.237
3	149.589	101.293	100.462	101.555	100.967	101.192
4	3863.337	138.506	115.846	174.693	156.566	162.611
5	3047.871	123.199	108.897	135.628	124.183	129.428
6	157.477	101.408	100.519	101.709	101.065	101.351
7	4250.210	140.360	117.042	183.058	163.277	170.577
8	3668.261	124.789	109.681	139.227	126.630	133.080
9	165.314	101.531	100.573	101.870	101.165	101.509
10	4092.805	152.541	132.970	220.097	216.802	281.370
11	3572.751	136.951	121.883	162.603	150.777	188.479
12	380.921	102.973	101.537	103.092	102.137	103.638
13	4458.495	156.441	137.052	263.956	271.523	348.009
14	4252.757	142.159	126.022	185.183	170.741	229.743
15	693.791	103.728	102.092	104.010	102.778	105.441
16	4591.032	159.747	140.752	312.908	343.692	409.781
17	4529.585	147.052	130.014	213.007	196.953	273.158
18	1330.044	104.663	102.704	105.128	103.552	107.376
19	4278.263	155.749	140.130	230.630	230.915	334.510
20	3903.283	140.619	128.909	170.241	158.482	216.808
21	475.965	103.528	102.253	103.546	102.458	104.280
22	4525.571	160.285	144.804	296.978	235.144	431.591
23	4389.340	147.535	134.691	208.791	195.734	288.479
24	1158.434	104.924	103.499	105.226	103.631	107.851
25	4611.770	164.106	148.986	375.247	470.715	522.441
26	4574.373	154.016	140.292	263.575	256.778	370.945
27	2594.270	106.872	105.086	107.592	105.272	112.401

Regeneration Rate

Trial	Brain	Liver	Kidney	RP	SP	Diaphragm
1	1098.366	116.901	108.398	132.944	116.783	111.792
2	396.372304	108.610176	104.387	115.664	107.620	105.608
3	107.518512	100.444	100.237	100.769	100.358	100.275
4	627.237	114.545	106.962	126.811	113.713	109.179
5	290.697	107.304	103.586	112.859	106.270	104.372
6	106.101	100.373	100.192	100.638	100.296	100.215
7	255.151	108.623	103.619	113.611	107.002	103.927
8	169.276	104.122	101.790	106.608	103.238	101.855
9	103.047	100.202	100.092	100.333	100.155	100.091
10	4239.238	140.750	117.296	184.841	164.805	171.928
11	3654.258	125.150	109.850	140.257	127.354	133.781
12	167.014	101.563	100.585	101.910	101.190	101.542
13	3863.337	138.506	115.846	174.693	156.566	162.611

14	3047.871	123.199	108.874	135.628	124.183	129.428
15	159.477	101.408	100.519	101.709	101.065	101.351
16	2743.358	130.928	111.438	148.343	135.794	139.224
17	1700.133	117.199	106.147	123.324	115.781	118.403
18	134.974	100.964	100.341	101.149	100.717	100.852

Bronchial Scrubbing

Partition Coefficients

Trial	Brain	Liver	Kidney	RP	SP	Diaphragm
1	272.200	107.900	106.800	126.000	110.400	106.000
2	166.700	104.000	103.500	112.600	104.900	102.900
3	102.600	100.200	100.200	100.600	100.200	100.100
4	272.200	107.900	106.800	126.000	110.400	106.000
5	166.700	104.000	103.500	112.600	104.900	102.900
6	102.600	100.200	100.200	100.600	100.200	100.100
7	2443.900	119.100	106.300	123.700	117.100	120.700
8	1141.900	109.400	103.200	111.300	107.600	109.600
9	116.800	100.500	100.200	100.600	100.400	100.400
10	2447.100	119.200	106.300	123.700	117.200	120.700
11	1143.900	109.400	103.200	111.400	107.700	109.600
12	116.900	100.500	100.200	100.600	100.400	100.400
13	4028.300	121.200	112.400	120.800	118.200	148.300
14	3412.600	110.100	106.600	110.000	108.000	121.700
15	163.400	100.500	100.400	100.500	100.400	100.800
16	4053.600	121.400	112.500	120.900	118.300	148.400
17	3435.500	110.200	106.800	110.000	108.000	121.700
18	163.900	100.500	100.400	100.500	100.400	100.800
19	1140.300	120.800	117.400	186.100	135.400	119.100
20	436.400	111.600	110.000	141.500	116.100	109.300
21	108.600	100.700	100.600	102.000	100.800	100.500
22	1141.600	120.900	117.400	186.100	135.300	119.100
23	436.800	111.600	110.000	141.400	116.100	109.300
24	108.600	100.700	100.600	102.000	100.800	100.500
25	3909.400	139.700	116.400	178.300	159.800	165.200
26	3122.600	124.100	109.200	137.300	125.400	130.600
27	160.600	101.500	100.500	101.800	101.100	101.400
28	3914.100	139.700	116.400	178.400	159.900	165.200
29	3126.900	124.100	107.200	137.300	125.500	130.600
30	160.700	101.500	100.500	101.800	101.100	101.400
31	4436.300	142.000	127.400	168.800	163.700	244.000
32	4221.700	125.300	117.100	132.700	126.500	168.000
33	389.200	101.500	101.100	101.500	101.100	102.500
34	4462.400	142.300	127.500	169.300	164.200	244.300
35	4248.900	125.500	117.200	133.000	126.800	168.100
36	392.500	101.500	101.100	101.500	101.100	102.500

37	3557.200	142.600	134.700	344.600	235.600	163.200
38	2256.200	128.700	123.900	238.000	157.600	130.900
39	129.900	102.100	101.900	106.600	102.500	101.500
40	3557.700	142.600	134.700	344.700	235.600	163.200
41	2256.700	128.700	123.900	238.000	157.600	130.900
42	129.900	102.100	101.900	106.600	102.500	101.500
43	4514.800	158.800	133.400	328.900	332.200	294.500
44	4338.500	146.100	122.500	225.100	193.800	199.200
45	397.900	104.600	101.700	105.800	103.500	104.600
46	4519.700	158.900	133.400	329.300	332.600	294.600
47	4343.500	146.100	122.500	225.300	193.900	199.200
48	398.500	104.600	101.700	105.800	103.500	104.600
49	4581.200	159.900	144.400	308.700	346.100	445.700
50	4524.400	147.200	134.200	210.700	198.000	300.700
51	1813.100	104.200	103.500	105.000	103.500	108.200
52	4604.600	160.400	144.600	310.300	348.700	447.100
53	4550.400	147.600	134.400	211.600	198.900	301.200
54	1836.000	104.700	103.500	105.000	103.600	108.200
55	4066.100	150.800	141.300	415.200	330.300	198.800
56	3246.100	137.500	130.900	305.500	197.100	149.000
57	150.200	103.300	103.000	110.400	103.800	102.400
58	4066.700	150.800	141.300	415.200	330.300	198.800
59	3246.600	137.500	130.900	305.500	197.100	149.000
60	150.200	103.300	103.000	110.400	103.800	102.400
61	4575.900	163.700	140.100	400.900	470.600	374.100
62	4477.300	153.700	129.400	289.100	259.300	251.100
63	725.700	107.000	102.700	109.200	105.500	107.200
64	4580.700	163.800	140.100	401.300	471.200	374.200
65	4482.200	153.800	129.400	289.400	259.500	251.200
66	727.200	107.000	102.700	109.200	105.500	107.200
67	44600.400	164.400	149.300	381.600	487.800	531.100
68	4560.800	154.600	140.800	270.000	266.000	380.700
69	2680.000	107.100	105.300	107.900	105.500	113.000
70	4622.500	164.800	149.600	383.700	491.800	533.000
71	4586.000	154.900	141.000	271.300	267.700	381.700
72	2707.800	107.200	105.300	108.000	105.500	113.000
71	4586.000	154.900	141.000	271.300	267.700	381.700
72	2707.800	107.200	105.300	108.000	105.500	113.000

Inhibition Coefficient

Trial	Brain	Liver	Kidney	RP	SP	Diaphragm
1	255.800	106.400	103.000	110.300	105.300	103.700
2	159.900	103.000	101.500	105.000	102.400	101.800
3	103.400	100.100	100.100	100.200	100.100	100.100
4	255.800	106.400	103.000	110.300	105.300	103.700
5	160.000	103.000	101.500	105.000	102.400	101.800

6	102.400	100.100	100.100	100.200	100.100	100.100
7	3028.900	137.800	121.100	213.300	162.300	138.500
8	1796.500	123.300	112.400	154.500	126.800	118.300
9	126.600	101.500	100.800	102.600	101.200	100.900
10	3030.000	137.800	121.100	213.300	162.300	138.500
11	1797.300	123.300	112.400	154.600	126.800	118.300
12	126.600	101.500	100.800	102.600	101.200	100.900
13	4339.700	163.100	145.200	445.000	163.100	145.200
14	3985.400	153.400	135.300	347.200	274.300	195.000
15	308.200	107.200	103.900	113.800	106.200	104.700
16	4341.000	163.100	145.300	445.100	484.100	283.800
17	3986.700	153.400	135.400	347.300	274.400	195.000
18	308.300	107.200	103.900	113.800	106.200	104.700
19	623.600	107.000	102.100	107.100	105.100	106.300
20	266.500	103.100	101.000	103.400	102.300	103.000
21	105.000	100.100	100.100	100.200	100.100	100.100
22	624.600	107.000	102.100	107.100	105.400	106.300
23	266.700	103.100	101.000	103.500	102.300	103.000
24	105.000	100.100	100.000	100.200	100.100	100.100
25	3909.400	139.700	116.400	178.300	159.800	165.200
26	3122.600	124.100	109.200	137.300	125.400	130.600
27	160.600	101.500	100.500	101.800	101.100	101.400
28	3914.100	139.700	116.400	178.400	159.900	165.200
29	3126.900	124.100	107.200	137.300	125.500	130.600
30	160.700	101.500	100.500	101.800	101.100	101.400
31	4520.700	163.900	140.500	398.600	468.900	374.600
32	4362.900	154.100	129.800	290.400	262.900	251.700
33	711.800	107.200	102.700	109.500	105.700	107.400
34	4525.500	164.000	140.600	399.000	469.600	374.800
35	4367.700	154.200	129.800	290.700	263.200	251.600
36	713.100	107.300	102.700	109.500	105.700	107.400
37	2518.000	107.600	103.300	106.200	105.200	112.100
38	999.100	103.200	101.700	103.000	102.300	105.500
39	112.100	100.100	100.100	100.100	100.100	100.100
40	2533.600	107.600	103.300	106.200	105.200	112.100
41	1006.500	103.300	101.700	103.000	102.400	105.500
42	112.100	100.100	100.100	100.200	100.100	100.200
43	4449.600	141.300	122.900	168.800	161.700	221.200
44	4213.900	124.800	113.700	132.600	125.800	156.600
45	282.900	101.500	100.800	101.500	101.100	102.200
46	4466.200	141.400	123.000	169.200	162.000	221.400
47	4230.900	124.900	113.700	132.800	125.900	156.700
48	284.100	101.500	100.800	101.500	101.100	102.200
49	4602.900	164.500	146.600	385.000	485.900	498.000
50	4554.300	154.700	137.100	273.700	266.400	348.900
51	2126.100	107.200	104.200	108.200	105.600	111.700
52	4617.700	164.700	146.700	386.300	488.300	499.100
53	4570.500	154.900	137.200	274.500	267.400	349.400

54	2141.100	107.300	104.200	108.300	105.600	111.700
55	3342.900	107.700	104.300	106.000	105.200	114.600
56	1843.500	103.200	102.100	102.900	102.300	106.500
57	116.600	100.100	100.100	100.100	100.100	100.200
58	3371.100	107.700	104.300	106.100	105.300	114.600
59	1865.900	103.300	102.200	103.000	102.400	106.500
60	116.700	100.100	100.100	100.100	100.100	100.200
61	4496.000	141.400	127.000	166.900	161.700	243.400
62	4341.800	124.800	116.800	131.700	125.600	167.300
63	385.600	101.400	101.100	101.500	101.100	102.500
64	4522.500	141.800	127.100	167.500	162.200	243.800
65	4369.600	125.000	116.900	131.900	125.900	167.500
66	388.200	101.500	101.100	101.500	101.100	102.500
67	44600.400	164.400	149.300	381.600	487.800	531.100
68	4560.800	154.600	140.800	270.000	266.000	380.700
69	2680.000	107.100	105.300	107.900	105.500	113.000
70	4622.500	164.800	149.600	383.700	491.800	533.000
71	4586.000	154.900	141.000	271.300	267.700	381.700
72	2707.800	107.200	105.300	108.000	105.500	113.000

Aging Rate

Trial	Brain	Liver	Kidney	RP	SP	Diaphragm
1	3103.200	137.600	115.000	169.400	152.800	155.500
2	2133.200	122.400	108.300	133.400	122.800	126.200
3	152.100	101.400	100.500	101.600	101.000	101.200
4	3106.000	137.700	115.000	169.500	152.900	155.500
5	2135.000	122.400	108.300	133.500	122.800	126.200
6	152.200	101.400	100.500	101.600	101.000	101.200
7	3909.400	139.700	116.400	178.300	159.800	165.200
8	3122.600	124.100	109.200	137.300	125.400	130.600
9	160.600	101.500	100.500	101.800	101.100	101.400
10	3914.100	139.700	116.400	178.400	159.900	165.200
11	3126.900	124.100	107.200	137.300	125.500	130.600
12	160.700	101.500	100.500	101.800	101.100	101.400
13	4285.100	141.500	117.600	187.200	167.100	173.600
14	3737.800	125.700	110.000	141.300	128.200	134.500
15	169.100	101.600	100.600	102.000	101.200	101.600
16	4290.000	141.600	117.600	187.300	167.200	173.600
17	3742.700	125.700	110.000	141.400	128.200	134.500
18	169.100	101.600	100.600	102.000	101.200	101.600
19	4115.100	153.500	133.700	225.000	223.500	289.300
20	3614.000	137.900	122.600	165.500	153.600	192.900
21	397.600	103.100	101.600	103.200	102.200	103.800
22	4128.000	133.700	133.800	225.300	223.900	289.300
23	3625.300	138.000	122.600	135.700	153.700	192.900
24	398.300	103.100	101.600	103.200	102.200	103.800

25	4464.800	157.300	137.700	270.400	282.000	357.300
26	4267.800	143.100	126.700	189.200	174.900	235.900
27	738.900	103.900	102.200	104.200	102.900	105.700
28	4480.000	157.500	137.900	271.200	283.000	357.700
29	4283.700	143.300	126.800	189.600	175.300	236.100
30	743.300	103.900	102.200	104.200	102.900	105.700
31	4590.700	160.400	141.400	320.600	358.600	419.600
32	4531.100	148.000	130.700	218.400	203.000	280.900
33	1398.300	104.900	102.800	105.400	103.700	107.700
34	4606.200	160.700	141.500	321.600	360.300	426.300
35	4547.600	148.200	130.800	219.000	203.600	281.200
36	1409.500	104.900	102.800	105.400	103.700	107.700
37	4287.000	156.500	140.800	235.600	238.000	344.300
38	3927.000	141.500	129.600	173.400	161.700	223.200
39	498.000	103.700	102.400	103.700	102.600	104.500
40	4306.700	156.900	140.900	236.100	238.600	344.400
41	3946.600	141.800	129.700	173.600	161.900	223.000
42	499.500	103.700	102.400	103.700	102.600	104.500
43	4521.700	160.800	145.300	303.200	337.000	441.400
44	4388.900	148.300	135.400	213.400	201.100	296.900
45	1219.900	105.100	103.700	105.500	103.800	108.200
46	4543.700	161.200	145.500	304.600	339.100	442.600
47	4413.500	148.600	135.500	214.200	201.900	297.300
48	1232.200	105.200	103.700	105.500	103.800	108.200
49	44600.400	164.400	149.300	381.600	487.800	531.100
50	4560.800	154.600	140.800	270.000	266.000	380.700
51	2680.000	107.100	105.300	107.900	105.500	113.000
52	4622.500	164.800	149.600	383.700	491.800	533.000
53	4586.000	154.900	141.000	271.300	267.700	381.700
54	2707.800	107.200	105.300	108.000	105.500	113.000

Regeneration Rate

Trial	Brain	Liver	Kidney	RP	SP	Diaphragm
1	1255.000	117.800	108.800	135.000	117.900	112.400
2	431.000	109.100	104.600	116.600	108.100	105.900
3	107.900	100.500	100.200	100.800	100.400	100.300
4	1255.900	117.800	108.800	135.000	117.900	112.400
5	431.200	109.100	104.600	116.600	108.100	105.900
6	108.000	100.500	100.200	100.800	100.400	100.300
7	649.800	115.100	107.100	127.800	114.200	109.400
8	298.600	107.600	103.700	113.300	106.500	104.500
9	106.300	100.400	100.200	100.700	100.300	100.200
10	650.000	115.100	107.100	127.800	114.200	109.400
11	298.600	107.600	103.700	113.300	106.500	104.500
12	106.300	100.400	100.200	100.700	100.300	100.200
13	259.000	108.900	103.700	114.000	107.200	103.900

14	170.900	104.200	101.800	106.800	103.300	101.900
15	103.100	100.200	100.100	100.300	100.200	100.100
16	259.100	108.900	103.700	114.000	107.200	103.900
17	171.000	104.200	101.800	106.800	103.300	101.900
18	103.100	100.200	100.100	100.300	100.200	100.100
19	4272.100	141.900	117.900	189.000	168.700	174.980
20	3722.500	126.100	110.200	142.200	128.800	135.200
21	170.900	101.600	100.600	102.000	101.200	101.600
22	4277.000	142.000	117.900	189.200	168.900	175.000
23	3727.400	126.100	110.200	142.300	128.800	135.200
24	171.000	101.600	100.600	102.000	101.200	101.600
25	3909.400	139.700	116.400	178.300	159.800	165.200
26	3122.600	124.100	109.200	137.300	125.400	130.600
27	160.600	101.500	100.500	101.800	101.100	101.400
28	3914.100	139.700	116.400	178.400	159.900	165.200
29	3126.900	124.100	107.200	137.300	125.500	130.600
30	160.700	101.500	100.500	101.800	101.100	101.400
31	2808.900	132.000	111.800	150.600	137.700	140.800
32	1765.200	117.900	106.400	124.400	116.600	119.100
33	136.700	101.000	100.400	101.200	100.700	100.900
34	2812.700	132.100	111.800	150.700	137.800	140.800
35	1768.000	117.900	106.400	124.400	116.600	119.100
36	136.700	101.000	100.400	101.200	100.700	100.900

Dermal

Partition Coefficients

Trial	Brain	Liver	Kidney	RP	SP	Diaphragm
1	1947.194	114.710	104.933	117.978	112.616	115.658
2	788.988	107.248	102.521	108.679	105.753	107.341
3	112.713	100.362	100.133	100.435	100.273	100.345
4	3667.559	133.410	113.371	159.511	143.135	149.592
5	2700.925	119.460	107.363	128.447	118.944	123.348
6	144.001	101.137	100.420	101.380	100.859	101.089
7	4462.555	154.452	129.258	286.370	265.231	253.601
8	4218.055	140.685	118.920	196.392	167.729	176.259
9	292.320	103.548	101.339	104.462	102.720	103.541
10	4548.097	160.450	136.281	360.132	375.992	324.290
11	4412.282	149.100	125.433	250.651	214.450	218.332
12	484.473	105.472	102.090	107.077	104.239	105.601
13	170.629	101.597	100.575	101.899	101.202	101.528
14	130.178	100.786	100.286	100.936	100.588	100.747
15	100.972	100.638	100.014	100.046	100.029	100.037
16	454.778	104.884	101.790	106.072	103.822	104.837
17	220.197	102.443	100.897	102.984	101.864	102.361
18	103.034	100.120	100.045	100.147	100.092	100.116

19	2243.587	114.053	105.472	120.121	112.486	115.903
20	849.624	107.434	102.824	109.748	105.971	107.724
21	109.285	100.384	100.146	100.475	100.289	100.376
22	3180.530	120.303	108.249	132.421	119.844	125.286
23	1634.389	111.214	104.359	115.581	109.388	112.263
24	114.071	100.603	100.230	100.748	100.446	100.592
25	3718.867	149.858	117.331	182.791	176.700	176.353
26	3134.724	129.087	109.312	137.446	129.047	133.444
27	164.156	101.479	100.534	101.760	101.113	101.414
28	4434.144	163.393	134.072	327.697	376.976	311.775
29	4182.896	150.066	122.298	221.154	205.276	203.083
30	413.352	104.537	101.662	105.624	103.536	104.475
31	4616.141	170.292	149.243	483.428	730.736	531.301
32	4567.528	164.553	139.939	396.032	479.793	376.247
33	2070.432	113.159	105.104	118.603	111.498	114.708
34	4634.613	171.627	153.091	517.715	814.063	607.194
35	4606.704	167.766	145.846	456.154	633.503	464.488
36	3043.844	119.126	107.720	129.948	118.283	123.384
37	677.939	106.478	102.263	107.758	105.112	106.522
38	283.206	103.194	101.136	103.801	102.438	103.112
39	105.090	100.158	100.059	100.191	100.120	100.152
40	2502.003	117.207	106.664	125.326	116.729	120.731
41	1189.849	109.422	103.474	112.255	102.832	109.873
42	116.423	100.498	100.186	100.606	100.377	100.479
43	4156.808	138.357	117.476	186.030	159.166	167.931
44	3517.499	124.431	110.052	141.310	126.283	132.554
45	156.532	101.572	100.595	101.949	101.186	101.549
46	4377.999	146.989	123.771	235.779	199.515	205.986
47	4011.118	132.869	114.555	166.822	142.803	151.655
48	194.612	102.449	100.933	103.075	101.838	102.440
49	4262.471	160.705	126.128	252.727	274.520	239.598
50	3811.519	146.555	115.614	171.744	163.959	165.934
51	239.175	102.646	100.946	103.147	102.006	102.561
52	4544.075	168.757	143.074	418.693	593.928	428.506
53	4408.499	161.749	131.964	306.424	335.198	288.125
54	915.707	107.904	102.907	110.120	106.433	108.124
55	4636.282	172.261	154.230	525.494	838.608	632.828
56	4609.966	169.607	147.821	470.214	693.492	504.001
57	3243.355	121.219	108.566	133.953	121.382	126.775
58	4646.646	122.920	156.633	545.240	877.347	686.667
59	4631.003	171.174	152.040	509.295	792.278	584.639
60	3847.717	129.187	112.565	154.929	134.573	142.539
61	2969.884	126.125	108.415	133.182	125.225	129.517
62	1706.454	112.971	104.384	115.779	110.911	113.666
63	4020.368	153.019	119.290	196.469	193.463	188.983
64	4121.567	147.377	120.646	208.344	190.719	191.708
65	3538.464	130.649	112.097	152.172	137.044	143.368
66	192.932	102.631	100.746	102.471	101.542	101.953

67	4555.695	163.207	138.267	378.954	437.010	353.520
68	4432.588	152.199	127.309	267.499	240.514	236.345
69	632.638	106.224	102.356	108.047	104.921	106.379
70	4606.029	166.833	144.443	443.025	592.268	440.669
71	4531.486	158.712	134.368	339.948	337.314	301.974
72	1235.129	109.458	103.653	112.836	107.718	110.120
73	4539.602	169.836	143.788	474.003	639.184	446.155
74	4400.030	165.202	132.597	326.423	389.398	299.526
75	970.761	108.386	102.900	110.074	106.737	108.519
76	4624.377	172.551	154.432	540.582	839.245	638.689
77	4584.236	170.702	148.608	473.671	715.816	509.244
78	2872.422	121.173	108.057	131.639	121.247	126.029
79	4654.120	173.610	1858.997	567.220	909.724	744.467
80	4644.866	172.961	156.479	545.999	876.486	683.253
81	4267.291	142.798	120.295	206.787	176.753	184.692
82	4658.059	173.803	159.824	571.830	919.736	764.746
83	4651.990	173.377	158.160	558.439	899.669	723.008
84	4439.745	150.964	126.981	265.094	230.162	230.647
85	4262.471	160.705	126.128	252.727	274.520	239.598
86	3811.519	146.555	115.614	171.744	163.959	165.934
87	239.175	102.646	100.916	103.147	102.009	102.532
88	4544.075	168.757	143.074	418.693	593.928	428.506
89	4408.499	161.749	131.964	306.424	335.198	288.125
90	915.707	107.904	102.907	110.120	106.433	108.124
91	4636.282	172.261	154.230	525.494	838.608	632.828
92	4609.966	169.607	147.821	470.214	693.492	504.001
93	3243.355	121.219	108.566	133.953	121.382	126.775
94	4646.646	122.920	156.633	545.240	877.347	686.667
95	4631.003	171.174	152.040	509.295	792.278	584.639
96	3847.717	129.187	112.565	154.929	134.573	142.539

Inhibition Coefficient

Trial	Brain	Liver	Kidney	RP	SP	Diaphragm
1	2621.650	132.253	117.756	187.629	145.687	129.837
2	1342.950	119.100	110.169	141.965	120.245	114.298
3	120.193	101.147	100.610	102.006	100.927	100.704
4	3667.559	133.410	113.371	159.511	143.135	149.592
5	2700.925	117.460	107.363	128.447	118.944	123.348
6	144.001	101.137	100.420	101.380	100.859	101.089
7	4383.933	134.530	119.101	151.937	143.844	191.789
8	4059.472	119.871	111.033	124.714	118.969	142.041
9	221.350	101.176	100.649	101.185	100.839	101.704
10	4457.910	134.663	122.859	150.483	143.781	209.050
11	4247.429	119.860	113.657	123.977	118.861	149.689
12	280.963	101.109	100.828	101.138	100.824	101.888
13	221.575	104.885	102.570	108.861	104.117	103.081

14	149.561	102.477	101.307	104.376	102.026	101.529
15	101.793	100.123	100.067	100.216	100.100	100.076
16	454.778	104.884	101.790	106.072	103.822	104.837
17	220.477	102.447	100.898	102.984	101.864	102.361
18	103.034	100.120	100.045	100.148	100.092	100.116
19	1623.394	104.884	102.769	105.232	103.757	107.879
20	543.667	102.433	101.389	102.565	101.825	103.750
21	105.420	100.118	100.070	100.126	100.089	100.180
22	2360.160	104.830	106.823	105.040	103.701	108.892
23	850.785	102.400	101.773	102.466	101.794	104.182
24	106.583	100.117	100.090	100.122	100.088	100.199
25	4142.274	160.382	139.414	383.298	374.374	231.118
26	3573.963	147.437	127.959	270.984	209.702	162.245
27	209.569	104.541	102.389	108.204	103.809	102.854
28	4441.353	163.507	134.125	327.697	376.976	311.775
29	4182.896	150.066	122.298	221.154	205.532	203.150
30	413.352	104.537	101.662	105.624	103.536	104.475
31	4585.596	165.416	141.940	312.150	401.401	439.549
32	4521.542	152.336	129.613	206.879	109.385	283.529
33	1457.983	104.534	102.573	104.844	103.474	107.265
34	4594.659	165.660	145.777	309.014	405.950	478.000
35	4549.209	152.770	133.887	204.021	209.611	313.042
36	2175.855	104.482	103.275	104.665	103.421	108.186
37	1160.949	117.416	109.247	137.329	117.895	112.740
38	442.955	109.363	104.928	117.956	108.414	106.196
39	108.156	100.504	100.270	100.881	100.407	100.310
40	2502.003	117.707	106.664	125.326	116.729	120.731
41	1189.849	109.422	103.474	112.255	107.832	109.873
42	116.423	100.498	100.186	100.606	100.377	100.479
43	3977.744	118.046	110.036	121.987	116.717	137.037
44	3124.004	109.496	105.338	110.595	107.747	116.739
45	138.167	100.492	100.287	100.521	100.368	100.744
46	4194.129	118.021	112.472	121.321	116.609	143.649
47	3620.323	109.430	106.745	110.234	107.658	119.268
48	151.562	100.485	100.366	100.501	100.362	100.822
49	4386.891	166.679	147.298	460.469	581.808	322.920
50	4066.288	158.484	137.441	363.613	335.142	215.290
51	354.645	107.871	104.140	114.808	106.917	105.121
52	4544.075	168.757	143.074	418.693	593.928	428.506
53	4408.499	161.749	131.964	306.424	335.198	288.125
54	915.707	107.904	102.907	110.120	106.433	108.124
55	4613.240	169.771	149.643	408.508	633.843	559.946
56	4577.345	163.909	139.904	290.245	354.357	410.615
57	2766.489	107.947	104.479	108.740	106.350	113.602
58	4615.919	169.830	152.519	406.319	641.089	593.666
59	4588.572	164.213	143.913	287.023	357.829	449.004
60	3363.574	107.881	105.374	108.435	106.270	115.561
61	3448.636	145.009	126.171	254.730	194.714	155.224

62	2404.241	129.632	116.178	176.972	139.317	126.147
63	139.267	102.043	101.080	103.595	101.663	101.258
64	4121.567	147.377	120.646	208.344	190.719	191.708
65	3532.378	130.594	112.082	152.172	137.044	143.368
66	192.932	102.031	100.746	102.471	101.542	101.953
67	4506.079	149.433	127.777	195.290	193.680	265.086
68	4344.408	131.554	117.443	145.490	137.541	180.192
69	415.757	102.017	101.154	102.123	101.508	103.087
70	4538.677	149.800	132.033	192.717	193.830	292.739
71	4427.770	131.189	120.739	143.286	136.555	193.336
72	622.643	101.989	101.473	102.040	101.482	103.436
73	4584.309	171.892	156.462	550.924	830.983	553.696
74	4486.176	169.281	151.476	505.692	703.369	402.467
75	1521.565	120.739	111.075	146.704	122.685	115.890
76	4624.377	172.551	154.432	540.582	839.245	638.689
77	4584.236	170.702	148.008	473.671	715.816	509.244
78	2872.422	121.173	108.057	131.639	121.247	126.029
79	4639.865	172.767	157.700	536.308	857.276	715.864
80	4625.643	171.330	153.404	465.414	751.566	627.192
81	4125.079	121.659	112.010	127.504	121.316	147.182
82	4638.674	172.713	158.844	535.109	858.906	732.229
83	4626.120	171.325	155.599	436.783	757.081	654.977
84	4290.076	121.663	114.807	126.694	121.209	155.889
85	4386.891	166.679	147.298	460.469	581.808	322.920
86	4066.288	158.484	137.441	363.613	335.142	215.290
87	354.645	107.871	104.140	114.808	106.917	105.121
88	4544.075	168.757	143.074	418.693	593.928	428.506
89	4408.499	161.749	131.964	306.424	335.198	288.125
90	915.707	107.904	102.907	110.120	106.433	108.124
91	4613.240	169.771	149.643	408.508	633.843	559.946
92	4577.345	163.909	139.904	290.245	354.357	410.615
93	2766.489	107.947	104.479	108.740	106.350	113.602
94	4615.919	169.830	152.519	406.319	641.089	593.666
95	4588.572	164.213	143.913	287.023	357.829	449.004
96	3363.574	107.881	105.374	108.435	106.270	115.561

Aging Coefficient

Trial	Brain	Liver	Kidney	RP	SP	Diaphragm
1	3667.559	133.410	113.371	159.511	143.135	149.592
2	2700.925	119.460	107.363	128.447	118.944	123.348
3	144.001	101.137	100.420	101.380	100.859	101.089
4	4407.579	152.239	133.647	235.490	229.931	306.320
5	4149.424	137.473	122.737	168.363	154.349	203.545
6	510.430	103.042	101.693	103.222	102.230	104.364
7	4486.162	156.562	141.846	266.240	273.182	384.305
8	4311.776	142.966	131.212	188.084	173.313	252.359

9	861.057	103.981	102.844	104.189	102.906	106.286
10	454.778	104.844	101.790	106.072	103.822	104.837
11	220.477	102.447	100.850	102.984	101.864	102.361
12	103.034	100.120	100.045	100.148	100.092	100.116
13	2607.884	112.177	106.885	114.437	110.187	120.225
14	1433.995	106.366	103.572	107.029	104.895	109.639
15	112.721	100.323	100.185	100.343	100.236	100.458
16	3132.127	115.506	111.013	118.855	113.410	129.595
17	2053.117	108.307	105.901	109.132	106.406	113.972
18	117.334	100.433	100.314	100.446	100.308	100.657
19	4441.353	163.507	134.125	327.692	376.976	311.775
20	4182.896	150.066	122.298	221.154	205.532	203.150
21	413.352	104.537	101.662	105.624	103.536	104.475
22	4594.851	170.492	152.305	437.418	651.931	601.282
23	4530.362	164.038	143.838	337.711	400.718	446.945
24	2487.102	111.384	106.428	113.356	109.406	118.657
25	4612.304	171.448	156.031	459.959	699.200	662.514
26	4568.145	166.466	150.072	364.576	467.470	530.444
27	3030.131	114.545	110.328	117.440	112.372	127.265
28	2502.003	117.707	106.664	125.326	116.729	120.731
29	1189.849	109.422	103.474	112.255	107.832	109.873
30	116.423	100.498	100.186	100.606	100.377	100.479
31	4088.701	135.106	121.124	160.984	147.603	191.948
32	3523.634	121.613	112.482	129.424	121.293	142.665
33	203.160	101.328	100.752	101.408	100.972	101.895
34	4269.781	140.638	129.441	178.896	164.125	235.915
35	3859.981	126.451	118.905	138.458	128.436	163.232
36	271.189	101.763	101.269	101.826	101.262	102.711
37	4544.075	168.757	143.074	418.693	593.928	428.506
38	4408.499	161.749	131.964	306.424	335.198	288.125
39	915.207	107.904	102.907	110.120	106.433	108.124
40	4622.453	172.383	156.350	495.943	788.740	683.604
41	4586.382	169.804	151.098	420.853	610.720	577.825
42	3311.199	118.643	110.687	124.234	117.426	134.771
43	4631.819	172.830	158.567	509.838	812.658	723.293
44	4606.430	170.937	155.239	445.558	664.127	644.218
45	3697.922	123.102	116.472	131.681	123.099	151.364
46	4121.567	147.377	120.646	208.344	190.719	191.208
47	3532.378	130.594	112.082	152.172	137.044	143.368
48	192.932	102.031	100.746	102.471	101.452	101.953
49	4515.795	162.414	142.298	315.800	365.162	422.639
50	4374.301	149.727	131.675	220.789	210.880	284.332
51	1194.038	105.318	102.983	105.807	104.035	107.932
52	4558.358	165.144	148.916	348.442	430.459	507.433
53	4463.968	154.352	140.080	249.947	248.718	358.114
54	1737.615	106.969	104.955	107.565	105.275	111.479
55	4626.377	172.551	154.432	540.583	839.245	638.689
56	4584.236	170.702	148.008	473.671	715.816	509.244

57	2872.422	121.173	108.057	131.639	121.247	126.029
58	4647.187	173.585	159.890	561.372	893.069	764.651
59	4634.181	173.016	158.075	526.399	842.375	721.285
60	4199.265	139.653	124.253	175.812	161.429	215.218
61	4649.943	173.700	160.583	564.587	898.966	778.412
62	4640.396	173.288	159.584	535.479	856.755	749.487
63	4345.937	145.071	132.824	197.240	182.931	268.597
64	4544.075	168.757	143.074	418.693	593.928	428.506
65	4408.499	161.749	131.964	306.424	335.198	288.125
66	915.207	107.904	102.907	110.120	106.433	108.124
67	4622.453	172.383	156.350	495.943	788.740	683.604
68	4622.453	172.383	156.350	495.943	610.720	577.825
69	3369.092	119.358	111.107	125.427	118.327	136.519
70	4631.819	172.830	158.567	509.838	812.658	723.293
71	4606.430	170.937	155.239	445.558	664.127	644.218
72	3697.922	123.102	116.472	131.681	123.099	151.364

Regeneration Rate

Trial	Brain	Liver	Kidney	RP	SP	Diaphragm
1	485.217	111.803	105.692	121.351	110.726	107.278
2	241.900	105.909	102.916	110.314	104.982	103.494
3	104.878	100.301	100.155	100.516	100.239	100.173
4	3667.559	133.410	133.371	159.511	143.135	149.592
5	2700.925	119.460	107.363	128.447	118.944	123.348
6	144.001	101.137	100.420	101.380	100.859	101.089
7	123.325	101.320	100.668	102.251	101.053	100.757
8	110.945	100.652	100.332	101.112	100.518	100.373
9	100.459	100.032	100.017	100.056	100.026	100.019
10	454.778	104.884	101.790	106.072	103.822	104.837
11	220.477	102.447	100.898	102.984	101.864	102.361
12	103.034	100.120	100.045	100.148	100.092	100.116
13	485.217	111.803	105.692	121.351	110.726	107.278
14	241.900	105.909	102.916	100.314	104.982	103.494
15	104.459	100.032	100.017	100.056	100.239	100.173
16	4441.353	163.507	134.125	327.697	376.976	311.775
17	4182.896	150.066	122.298	221.154	205.532	203.150
18	413.332	104.537	101.662	105.624	103.536	104.475
19	123.325	101.320	100.668	102.251	101.053	100.757
20	110.945	100.652	100.332	101.112	400.518	100.373
21	100.459	100.032	100.017	100.056	100.026	100.019
22	2502.003	117.707	106.664	125.325	116.729	120.731
23	1189.849	109.422	103.474	112.255	107.832	109.873
24	116.423	100.498	100.186	100.606	100.377	100.479
25	2938.138	152.402	128.274	267.451	225.443	163.428
26	1900.293	136.386	117.392	183.015	149.729	129.284
27	140.970	102.180	101.097	103.732	101.756	101.256

28	4544.075	168.757	143.074	418.693	593.928	428.506
29	4408.499	161.749	131.964	306.424	355.198	288.125
30	915.707	107.904	102.907	110.120	106.433	108.174
31	963.057	120.476	109.666	139.405	120.943	113.534
32	420.914	110.446	105.061	118.734	109.328	106.378
33	108.976	100.540	100.276	100.921	100.429	100.310
34	4121.567	147.377	120.646	208.344	190.719	191.708
35	3532.378	130.594	112.082	152.172	137.044	143.368
36	192.932	102.031	100.746	102.471	101.542	101.953
37	4053.276	166.543	145.901	479.870	523.745	298.390
38	3431.556	158.942	134.999	349.757	307.075	196.712
39	262.992	106.535	103.216	111.448	105.553	103.881
40	4624.377	172.551	154.432	540.582	839.245	638.689
41	4584.236	170.702	148.008	473.671	715.816	509.244
42	2872.422	121.173	108.057	131.639	212.247	126.029
43	2938.138	152.402	128.274	267.451	225.443	163.428
44	1900.293	136.386	117.392	183.015	149.729	129.284
45	140.970	102.108	101.097	103.732	101.756	101.256
46	4544.075	168.757	143.074	418.693	593.928	428.506
47	4408.499	161.749	131.964	306.424	355.198	288.125
48	915.707	107.904	102.907	110.120	106.433	108.174

Appendix 10 Parameter Values

<u>NAME</u>	<u>VALUE</u>	<u>UNITS</u>	<u>SOURCE</u>
Parameters			
Blood Fraction Coeff			
Brain BFC	0.134	Unitless	a
Liver BFC	0.2700	Unitless	a
Kidney BFC	0.2230	Unitless	a
Fat BFC	0.0360	Unitless	a
SP BFC	0.073	Unitless	a
RP BFC	0.1583	Unitless	a
Diaphragm BFC	0.006	Unitless	a
Physical Parameters			
Body weight	60.6	kg	a
Pulmonary Flow	17		a
Cardiac Flow	14.5		a
Chemical Coeff			
MW	184.15	g/mol	
Volume Fraction Coeff			
Brain VFC	0.0214	Unitless	a
Liver VFC	0.04	Unitless	a
Kidney VFC	0.0043	Unitless	a
Fat VFC	0.17	Unitless	a

Slowly VFC	0.5514	Unitless	a
Richly VFC	0.0343	Unitless	a
Diaphragm VFC	0.003	Unitless	a
Lung VFC	0.0086	Unitless	a
VB VFC	0.057	Unitless	a
AB VFC	0.02	Unitless	a
Partition Coeff			
Blood Air PC	Varies	Unitless	b
Brain BPC of OP	Varies	Unitless	b
Liver BPC of OP	Varies	Unitless	b
Kidney BPC of OP	Varies	Unitless	b
Fat BPC of OP	Varies	Unitless	b
SP BPC of OP	Varies	Unitless	b
RP BPC of OP	Varies	Unitless	b
Diaphragm BPC of OP	Varies	Unitless	b
Bronchial BPC of OP	Varies	Unitless	b
Skin BPC of OP	Varies	Unitless	b
Mich Men Cons			
Brain Vmax of OP	Varies	mg/hr	b
Liver Vmax of OP	Varies	mg/hr	b
Kidney Vmax of OP	Varies	mg/hr	b
RP Vmax of OP	Varies	mg/hr	b
Brain Km of OP	Varies	mg/l	b

Liver Km of OP	Varies	mg/l	b
Kidney Km of OP	Varies	mg/l	b
RP Km of OP	Varies	mg/l	b
Variable Parameters			
Air Conc	Varies	mg/l	
Exposure to Skin	Varies	mg	
Scrubbing Coeff	Varies	Unitless	
Skin Transfer Coeff	Varies	(cm ² - hr) ⁻¹	
Skin Surface Area	Varies	cm ²	
AChE Inhibition Rate	Varies	1/hr	b
AChE Aging Rate	Varies	1/hr	b
AChE Regeneration Rate	Varies	1/hr	b
Other			
Hundred Percent	100	Unitless	
AChE Hydrolysis of ACh	0.02	(nM - hr) ⁻¹	
Lung			
Exhaled	0	mg	
Arterial Blood Flow			
AB inhibition rate for AChE	0.01416	(nM - hr) ⁻¹	a
AB inhibition rate for BuChE	0.4248	(nM - hr) ⁻¹	b
AB inhibition rate for CaE	0.00108	(nM - hr) ⁻¹	b
AB OP lost enzymes	0	nmol	b
Initial quantity of AB AChE	1.18826	nmol	b

Initial quantity of AB BuChE	5.9413	nmol	b
Initial quantity of AB CaE	4990.69	nmol	b
Brain			
Brain ACh Release Rate	0.0761852	nmols/hr	
Brain AChE Homeostatic State	49.4	nmol	c
Brain AChE Synthesis Rate	0.0014	nmol/hr	a
Brain BuChE	16.9	nmol	b
Brain CaE	780	nmol	b
Brain ACh Homeostatic State	0.100	nmol	c
Brain OP lost AChE	0	mg	
Brain OP lost BuChE	0	mg	
Brain OP lost CaE	0	mg	
Brain OP lost Metab	0	mg	
Free brain AChE	49.4	nmol	b
Inhibited Brain AChE	0	nmol	
OP in the Brian	0	mg	
Synthesis of Brain CaE	15.6	nmol	
Synthesis of Brain BuChE	0.169	nmol	
Synaptic Brain ACh	0.100	nmol	c
Liver			
Liver ACh Release Rate	0.001237624	nmols/hr	
Liver AChE Homeostatic State	1.5	nmol	c

Liver AChE Synthesis Rate	0.053	nmol/hr	a
Liver BuChE	12	nmol	b
Liver CaE	68250	nmol	b
Liver ACh Homeostatic State	0.100	nmol	c
Liver OP lost AChE	0	mg	
Liver OP lost BuChE	0	mg	
Liver OP lost CaE	0	mg	
Liver OP lost Metab	0	mg	
Free liver AChE	1.5	nmol	b
Inhibited liver AChE	0	nmol	
OP in liver	0	mg	
Synthesis of liver CaE	136.5	nmol	
Synthesis of liver BuChE	0.24	nmol	
Synaptic liver ACh	0.100	nmol	

Kidney

Kidney ACh Release Rate	0.0010022492	nmols/hr	
Kidney AChE Homeostatic State	0.13322	nmol	c
Kidney AChE Synthesis Rate	0.053	nmol/hr	a
Kidney BuChE	0.84	nmol	b
Kidney CaE	4620	nmol	b
Kidney ACh Homeostatic State	0.100	nmol	c
Kidney OP lost AChE	0	mg	

Kidney OP lost BuChE	0	mg	
Kidney OP lost CaE	0	mg	
Kidney OP lost Metab	0	mg	
Free kidney AChE	0.13322	nmol	b
Inhibited kidney AChE	0	nmol	
OP in kidney	0	mg	
Synthesis of kidney CaE	4620	nmol	
Synthesis of kidney BuChE	0.84	nmol	
Synaptic kidney ACh	0.100	nmol	

Richly Perfused Tissues

RP ACh Release Rate	0.008005465	nmols/hr	
RP AChE Homeostatic State	8.32	nmol	c
RP AChE Synthesis Rate	0.053	nmol/hr	a
RP BuChE	205.92	nmol	b
RP CaE	443040	nmol	b
RP ACh Homeostatic State	0.100	nmol	c
RP OP lost AChE	0	mg	
RP OP lost BuChE	0	mg	
RP OP lost CaE	0	mg	
RP OP lost Metab	0	mg	
Free RP AChE	8.32	nmol	b
Inhibited RP AChE	0	nmol	

OP in RP	0	mg	
Synthesis of RP CaE	88.608	nmol	
Synthesis of RP BuChE	205.92	nmol	
Synaptic RP ACh	0.100	nmol	
Fat			
OP in Fat	0	mg	
Slowly Perfused Tissues			
SP ACh Release Rate	0.013998	nmols/hr	
SP AChE Homeostatic State	233.87	nmol	c
SP AChE Synthesis Rate	0.053	nmol/hr	a
SP BuChE	200.46	nmol	b
SP CaE	76843	nmol	b
SP ACh Homeostatic State	0.100	nmol	c
SP OP lost AChE	0	mg	
SP OP lost BuChE	0	mg	
SP OP lost CaE	0	mg	
Free SP AChE	233.87	nmol	b
Inhibited SP AChE	0	nmol	
OP in SP	0	mg	
Synthesis of SP CaE	76843	nmol	
Synthesis of SP BuChE	200.46	nmol	
Synaptic SP ACh	0.100	nmol	

Diaphragm

Diaphragm ACh Release Rate	0.0117162	nmol/hr
Diaphragm AChE Homeostatic State	1.065	nmol
Diaphragm AChE Synthesis Rate	0.053	nmol/hr
Diaphragm BuChE	2.343	nmol
Diaphragm CaE	617.7	nmol
Diaphragm ACh Homeostatic State	0.100	nmol
Diaphragm OP lost AChE	0	mg
Diaphragm OP lost BuChE	0	mg
Diaphragm OP lost CaE	0	mg
Free Diaphragm AChE	1.065	nmol
Inhibited Diaphragm AChE	0	nmol
OP in Diaphragm	0	mg
Synthesis of Diaphragm CaE	617.7	nmol
Synthesis of Diaphragm BuChE	2.343	nmol
Synaptic Diaphragm ACh	0.100	nmol

Venous Blood Flow

Initial quantity of VB AChE	3.85416	(nM - hr) ⁻¹	a
Initial quantity of VB BuChE	19.2708	(nM - hr) ⁻¹	b
Initial quantity of VB CaE	161187.47	(nM - hr) ⁻¹	b
VB inhibition rate for AChE	0.4248	nmol	b
VB inhibition rate for BuChE	0.01416	nmol	b

VB inhibition rate for CaE	0.00108	nmol	b
VB OP lost enzymes	0	nmol	b
Bronchial			
OP in bronchial tissue	0	mg	
Bronchial BFC	0.0417	Unitless	e
Bronchial Vol	0.17484	l	e
Dermal			
OP in the skin	0	mg	
Skin BFC	0.058	Unitless	d
Vol of skin	2.2	l	d

- a. Gearhart, 1994
- b. Gentry, 2002
- c. Potter, 1970
- d. Poet, 2004
- e. Shelley, 1996

Bibliography

- Aidoo, Anthony Y., Ward, Kim. (2006). "Spatio-temporal concentration of acetylcholine in vertebrate synaptic cleft," *Mathematical and Computer Modeling*, 44: 952-962.
- Augerson, William. (2000). *A review of the scientific literature as it pertains to gulf war illnesses, Volume 5: Chemical and biological warfare agents*. Santa Monica, CA. Rand Corporation. Retrieved from http://www.rand.org/pubs/monograph_reports/MR1018.5/
- Aurbek, N., Thiermann, H., Szinicz, L., Eyer, P. and Worek, F. (2006). "Application of kinetic based computer modeling to evaluate the efficacy of HI 6 in percutaneous VX poisoning," *Toxicology*, 224: 74-80.
- Calvert, J.B. (2002). *Chemical Warfare*. Retrieved June 20, 2007, from <http://mysite.du.edu/~jcalvert/phys/wargas.htm>
- Cannard, Kevin. (2006) "The acute treatment of nerve agent exposure," *Journal of the Neurological Sciences*, 249: 86-94.
- Chambers, Janice E., and Oppenheimer, Seth F. (2004). "Organophosphates, Serine Esterase Inhibition, and Modeling of Organophosphate Toxicity," *Toxicological Sciences*, 77: 185-187.
- Costa, Lucio G. (2005) "Current issues in organophosphate toxicology," *Clinica Chimica Acta*-10082: 1-13.
- Covington, Tammie R., and Clewell, Harvey J., Fisher, Jeffrey W. (2004). "Development of a physiologically-based pharmacokinetic model of trichloroethylene and its metabolites for use in risk assessment," *Air Force Research Laboratory, Human Effectiveness Directorate, Biosciences and Protection Division, Applied Biotechnology Branch, WPAFB, OH, AFRL-HE-WP-TR-2006-0049*.
- Federation of American Scientists. (2006). *Types of chemical weapons*. Retrieved July 10, 2007, from <http://www.fas.org/cw/cwagents.htm>
- Gearhart, Jeffery M., Jepson, Gary W., Clewell, Harvey J., Andersen, Melvin E., and Conolly, Rory B. (1994). "Physiologically Based Pharmacokinetic Model for the Inhibition of Acetylcholinesterase by Organophosphate Esters," *Environ Health Perspective*, 102(Suppl 11): 51-60.

- Gearhart, Jeffery M. and Yu, Kyung O. "Development of a physiologically based pharmacokinetic/pharmacodynamic (PBPK/PD) minipig model for simulation of low level multiple route CW agent exposure," *Proceedings of the 2003 Joint Service Scientific Conference on Chemical & Biological Defense Research*, 17-20 November 2003.
- Genovese, Raymond F., Shippee, Sara J., Bonnell, Jessica, Benton, Bernard J., Mioduszewski, Robert J., and Jakubowski, Michael. "Evaluating performance effects of low-level inhalation exposure to nerve agents in rats," *Proceedings for the Army Science Conference (24th)* Held on 29 November – 2 December 2005 in Orlando, Florida.
- Gentry, Robinan P., Hack, C. Eric, Haber, Lynne, Maier, Andrew, and Clewell, III, Harvey J. (2002). "An approach for the quantitative consideration of genetic polymorphism data in chemical risk assessment: examples with warfarin and parathion," *Toxicological sciences*, 70: 120-139.
- Gray, P.J and Dawson, R.M. (1987). "Kinetic Constants for the Inhibition of Eel and Rabbit Brain Acetylcholinesterase by Some Organophosphates and Carbamates of Military Significance," *Toxicology and Applied Pharmacology*, 91: 140-144.
- Henderson, Rogene F., Barr, Edward B., Blackwell, Walter B., Clark, Connie R., Conn, Carole A., Kalra, Roma, et al. (2002). "Response of Rats to Low Levels of Sarin," *Toxicology and Applied Pharmacology*, 184: 67-76.
- Kennedy, Kelly. (2007). *Study: Sarin at root of Gulf War syndrome*. Retrieved May 30, 2007, from ArmyTimes.com
- Langenberg, Jan P., Van Dijk, Corry, Sweeney, Richard E., Maxwell, Donald M., De Jong, Leo P.A. and Benschop, Hendrik. (1997). "Development of a physiologically based model for the toxicokinetics of C(+)-P(+)-soman in the atropinized guinea pig," *Arch Toxicol*, 71: 320-331.
- Langston, Jeffrey L., Adkins, Angela L., Moran, Anita V., Rockwood, Gary A., and DeFord, Michelle S. (2005). "Effects of sarin on the operant behavior of guinea pigs," *Neurotoxicology and Teratology*, V27, Issue 6: 841-853.
- Leung, Hon-Wing and Paustenbach, Dennis J. (1995). "Physiologically based pharmacokinetic and pharmacodynamic modeling in health risk assessment and characterization of hazardous substances," *Toxicology Letters*, 79: 55-65.

- Lo, MM, Barnard, EA, and Dolly JO. (1982). "Size of acetylcholine receptors in the membrane. An improved version of the radiation inactivation method," *Biochemistry*, 21 (9): 2210-2217.
- Maxwell, Donald M., Lenz, David E., Groff, William A., Kaminskis, Andris and Froehlich, Harry L. (1987) "The Effects of Blood Flow and Detoxification on *in Vivo* Cholinesterase Inhibition by Soman in Rats," *Toxicology and Applied Pharmacology*, 88: 66-67.
- Maxwell, Donald M., Vlahacos, Constantine P. and Lenz, David E. (1988). "A pharmacodynamic model for soman in the rat," *Toxicology Letters*, 43: 175-188.
- Meggs, William J. (2003). "Permanent Paralysis at Sites of Dermal Exposure to Chlorpyrifos," *Journal of Toxicology*, 44 No 6: 883-886.
- NATO. (n.d.). *US Army Field Manual FM8-285, CHAPTER: 2 Nerve Agents*. Retrieved from <http://www.gulflink.osd.mil/campmont/n03en007/sarin.htm>
- Nishiwaki, Yuji, Maekawa, Kazuhiko, Ogawa, Yasutaka, Asukai, Nazomu, Minami, Masayasu, Omae, Kazuyuki and the Sarin Health Effects Study Group. (2001). "Effects of sarin on the nervous system in rescue team staff members and police officers 3 years after the Tokyo subway sarin attack," *Environmental Health Perspectives*, 109: 1169.
- Poet, T.S., Kousba, A.A., Dennison, S.L., and Timchalk, C. (2004). "Physiologically based pharmacokinetic/pharmacodynamic model for the organophosphate pesticide diazinon," *NeuroToxicology*, 25: 1013-1030.
- Potter, L. T. (1970). "Synthesis, storage and release of [¹⁴C]acetylcholine in isolated rat diaphragm muscles," *The Journal of Physiology Online*, 206: 145-166.
- Shelley, M.L. (1996). "A mathematical model of bronchial absorption of vapors in the human lung and its significance in pharmacokinetic modeling," *SAR and QSAR in Environmental Research*, 5: 221-253.
- Sopori, Mohan. (2006). "Neuroimmune Effects of Inhaling a Low Dose Sarin," Unpublished, Prepared for the U.S. Army Medical Research and Materiel Command, Fort Detrick, Maryland.
- Sweeny, Richard E., Langenberg, Jan P. and Maxwell, Donald M. (2006). "A physiologically based pharmacokinetic (PB/PK) model for multiple exposure routes of soman in multiple species," *Arch Toxicol* 80: 719-731.

US Army Medical Research Institute of Chemical Defense. (2000). *Medical Management of Chemical Casualties Handbook (3rd ed)*. Aberdeen Proving Grounds Maryland.

Wilson, Barry W., Henderson, John D. and Spencer, Peter S. (1998). "Clinical effects of low-level exposures to chemical warfare agents in mice and chickens," *Drug and Chemical Toxicology*, 21(Suppl. 1): 183-190.

Zoltani, CK and Baskin, SI. (2000). "Simulation of Acetylcholine Cardiac Overload Caused by Soman, a Cholinesterase Inhibitor," *Computers in Cardiology*, 27: 243-246.

REPORT DOCUMENTATION PAGE			Form Approved OMB No. 074-0188		
The public reporting burden for this collection of information is estimated to average 1 hour per response, including the time for reviewing instructions, searching existing data sources, gathering and maintaining the data needed, and completing and reviewing the collection of information. Send comments regarding this burden estimate or any other aspect of the collection of information, including suggestions for reducing this burden to Department of Defense, Washington Headquarters Services, Directorate for Information Operations and Reports (0704-0188), 1215 Jefferson Davis Highway, Suite 1204, Arlington, VA 22202-4302. Respondents should be aware that notwithstanding any other provision of law, no person shall be subject to a penalty for failing to comply with a collection of information if it does not display a currently valid OMB control number. PLEASE DO NOT RETURN YOUR FORM TO THE ABOVE ADDRESS.					
1. REPORT DATE (DD-MM-YYYY) 23-06-2008		2. REPORT TYPE Master's Thesis		3. DATES COVERED (From – To) September 2006 – March 2008	
4. TITLE AND SUBTITLE Comparative Kinetics and Distribution to Target Tissues of Organophosphates Using Physiologically-Based Pharmacokinetic Modeling			5a. CONTRACT NUMBER		
			5b. GRANT NUMBER		
			5c. PROGRAM ELEMENT NUMBER		
6. AUTHOR(S) Vermillion, Rick E, Captain, USAF			5d. PROJECT NUMBER		
			5e. TASK NUMBER		
			5f. WORK UNIT NUMBER		
7. PERFORMING ORGANIZATION NAMES(S) AND ADDRESS(S) Air Force Institute of Technology Graduate School of Engineering and Management (AFIT/EN) 2950 Hobson Way, Building 640 WPAFB OH 45433-8865			8. PERFORMING ORGANIZATION REPORT NUMBER AFIT/GEM/ENV/08-M20		
9. SPONSORING/MONITORING AGENCY NAME(S) AND ADDRESS(ES) AFRL/RH (AFMC) (937) 674-9503 2729 R Street B837 WPAFB OH, 45433-5707			10. SPONSOR/MONITOR'S ACRONYM(S)		
			11. SPONSOR/MONITOR'S REPORT NUMBER(S)		
12. DISTRIBUTION/AVAILABILITY STATEMENT APPROVED FOR PUBLIC RELEASE; DISTRIBUTION UNLIMITED.					
13. SUPPLEMENTARY NOTES					
14. ABSTRACT A physiologically – based pharmacokinetic model has been developed to examine the effects of organophosphates on the levels of acetylcholine in different tissues throughout the mammalian body. Many organophosphate-like chemical and kinetic characteristics are tested without reference to a specific chemical. Characteristics include partition coefficients, metabolic constants, the inhibition coefficient, the aging rate, and the regeneration rate. Two separate exposure scenarios are tested and compared against a baseline. The baseline consists of a direct inhalation exposure. The first exposure scenario examines the effects of bronchial scrubbing (via inhalation) and the second scenario is a study of dermal exposures and compares the levels of ACh in the different tissues with those in the inhalation (baseline) tests. Organophosphates that are absorbed directly into the bronchial tissue exhibit little variation on the levels of ACh buildup in any of the tissue groups tested when compared to the inhalation exposures. No matter what the scrubbing coefficient used, or the combination of the parameters (partition coefficients, inhibition coefficient, aging rate, and regeneration rate) values, the change in ACh was minimal. The results showed different behavior between inhalation and dermal exposures. The dermal results suggest that an individual may have additional time to don protective equipment before the levels of ACh are high enough to render the person incapable of doing so.					
15. SUBJECT TERMS Physiologically-based Pharmacokinetic (PBPK) Modeling, Acetylcholine (ACh), Organophosphates					
16. SECURITY CLASSIFICATION OF:			17. LIMITATION OF ABSTRACT UL	18. NUMBER OF PAGES 220	19a. NAME OF RESPONSIBLE PERSON Dr. Michael L. Shelley, ENV
a. REPORT U	b. ABSTRACT U	c. THIS PAGE U			19b. TELEPHONE NUMBER (Include area code) (937) 255-3636, ext 4594

Standard Form 298 (Rev. 8-98)
Prescribed by ANSI Std. Z39-18

